

HIGH POWER RELAY

1 POLE—12, 30, 40 A

(FOR AUTOMOTIVE APPLICATIONS)

FRL-274 SERIES

RoHS compliant

■ FEATURES

- High current switching and carry by using new conductive materials.
- Suitable for automotive applications such as ABS, power assisted steering, etc.
- High heat resistance (40A type)
Designed for use in high ambient temperature, such as engine compartment, and able to carry continuous current of 20 A in+125°C.
- New contact material
New contact material formulation which is resistant to welding.
- Three types of contact gaps (0.4mm, 1.0mm, 1.4mm)
- RoHS compliant since date code: 0631
Please see page 8 for more information

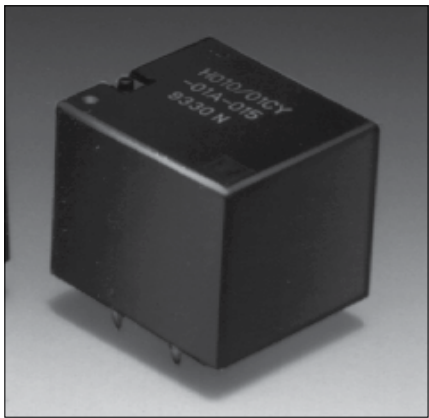

■ ORDERING INFORMATION

1. 40A Type

[Example] FRL-274 N D012 / 81 C Y -01A -001
 (a) (b) (c) (d) (e) (f) (g) (h)

(a)	Series Name	FRL-274: FRL-274 Series
(b)	Enclosure	N : Plastic sealed type
(c)	Nominal Voltage	D012 : 12 VDC
(d)	Carrying Current	81 : 40 A type
(e)	Contact Arrangement	A : 1 form A C : 1 form C
(f)	Contact Material	Y : Silver-tin oxide
(g)	Cover Terminal	01A : w/cover, wide terminal width
(h)	Custom Designation	To be assigned custom specification

FRL-274 SERIES

■ ORDERING INFORMATION

2. Standard Type

[Example] $\frac{\text{FRL-274}}{\text{(a)}} \frac{\text{N}}{\text{(b)}} \frac{\text{D}}{\text{(c)}} \frac{\text{012}}{\text{(d)}} / \frac{\text{01}}{\text{(e)}} \frac{\text{C}}{\text{(f)}} \frac{\text{S}}{\text{(g)}} - \frac{\text{01A}}{\text{(h)}} - \frac{\text{***}}{\text{(i)}} \frac{\text{(-S)}}{\text{(j)}}$

(a)	Series Name	FRL-274: FRL-274 Series
(b)	Enclosure	N : Plastic sealed type
(c)	Coil Type	D : Standard (nominal power 1.7 to 2.1 W) H : Low power (nominal power 0.6 W)
(d)	Nominal Voltage	009 : 9 VDC 012 : 12 VDC 024 : 24 VDC
(e)	Contact Gap	01 : Standard gap (0.4 mm gap) 51 : 1.0 mm gap 61 : 1.4 mm gap
(f)	Contact Arrangement	A : 1 form A (SPST-NO) C : 1 form C (SPDT)
(g)	Contact Material	Y : Silver-tin oxide
(h)	Cover Terminal	A : standard terminal width 01A : wide terminal width
(i)	Custom Designation	To be assigned custom specification
(j)	Package	Nil : Standard tray -S : Carrier tube

FRL-274 SERIES

■ SPECIFICATIONS

Item		Specifications		
		12V Battery		24V Battery
		30A	40A	
Contact	Arrangement	1 form A (SPDT-NO), 1 form C (SPDT)		
	Material	Silver-tin oxide		
	Voltage Drop (resistance)	Max. 100mV initial (at 1 A, 12VDC)		
	Rating	14 VDC 30A (motor lock)	14 VDC 40A (motor lock)	28 VDC 12A (motor lock)
	Gap	01: 0.4mm gap	01: 0.4mm gap	51: 1.0mm gap 61: 1.4mm gap
	Max. Carrying Current	20° C: 30A continuous 40A 10 minutes	20° C 40A continuous 50A 1 hour 125° C: 20A continuous 40A 10 minutes	20° C: 30A continuous
	Max. Switching Frequency	Mechanical: 1,000 operations/hour Electrical: 1,800 operations/hour		
	Min. Switching Load ^(*) (reference)	600mW minimum (50 mA minimum)		
Coil	Operating Temperature	-40° C to +85° C (no frost) (refer to Characterstic data)		
	Storage Temperature	-40° C to +100° C (no frost)		
Insulation	Resistance	Minimum 100MΩ (at 500VDC)		
	Dielectric Strength	500 VAC 1 minimum		
Time value	Operate (at nominal value)	0.4mm gap: max.10ms		1.0mm gap: max.10ms 1.4mm gap: max.15ms
	Release (at nominal value)	0.4mm gap: max.5ms		1.0mm gap: max. 8ms 1.4mm gap: max.10 ms
Life	Mechanical	10x10 ⁶ operations minimum		
	Electrical	100x10 ⁶ operations minimum		
Other	Vibration Resistance		10 to 55 Hz (double amplitude of 1.5mm)	
	Shock Resistance	Misoperation	100m/s ² (11± ¹ ms)	
		Endurance	1000m/s ² (11± ¹ ms)	
Weight		Approximately 20g		

*1 Values when switching a resistive load at normal room temperature and humidity and in a clean environment. The minimum applicable load varies with the switching frequency and operating environment.

FRL-274 SERIES

COIL DATA CHART

Type	Contact Gap	Nominal Power	Coil Voltage	Part Number	Coil Resistance (±10%) at 20° C	Must Operate Voltage		Coil Temperature Rise
						20° C	80° C	
12V Battery	0.4mm	lower power 0.6W	9 VDC	FRL-274NH009/01 □ Y - □□ A	135Ω	6.3 V	7.8 V	Approx. 35° C
			10 VDC	FRL-274NH010/01 □ Y - □□ A	165Ω	7.0 V	8.7 V	
			12 VDC	FRL-274NH012/01 □ Y - □□ A	240Ω	8.4 V	10.4 V	
		Standard 1.7W	12 VDC	FRL-274ND009/01 □ Y - □□ A	85Ω	6.5 V	8.0 V	Approx. 75° C
		40A type 0.87W	12VDC	FRL-274ND009/81 □ Y - 01	165Ω	6.3 V	8.0 V	Approx. 65° C
24V Battery	1.0mm	1.7W	24 VDC	FRL-274ND024/51 □ Y - □□ A	340Ω	16.8 V	21.0 V	Approx. 75° C
	1.4mm	2.1W	24 VDC	FRL-274ND024/61 □ Y - □□ A	275Ω	16.8 V	21.0 V	Approx. 85° C

CHARACTERISTIC DATA

1. MAXIMUM BREAK CAPACITY

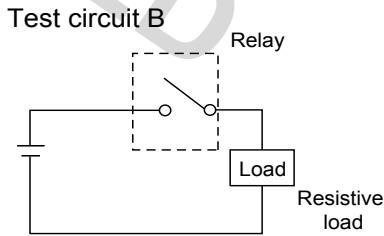
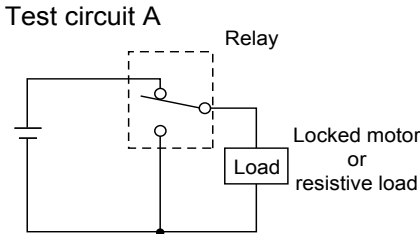
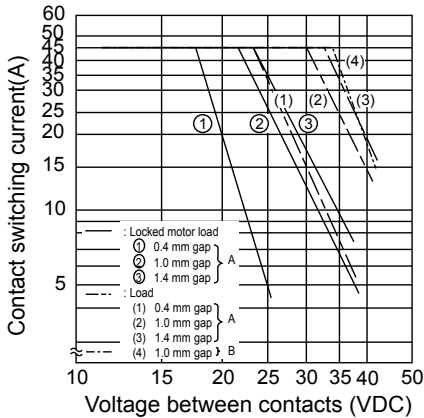

FRL-274 SERIES

2. OPERATING COIL VOLTAGE (EXAMPLE)

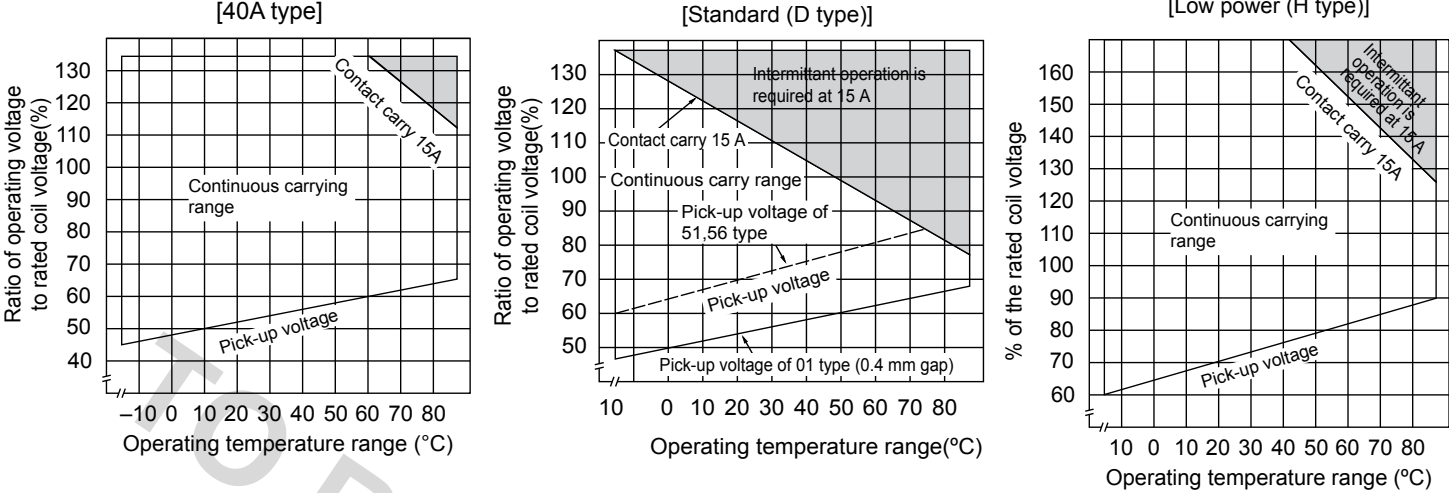

3. LIFE TEST (EXAMPLE)

[40A type]

- Test item
16 VDC, 40 A
Motor lock
 2×10^5 operations

•Test circuit

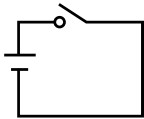

•Circuit wave form

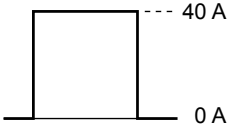

•Shift of pick-up and drop-out voltage

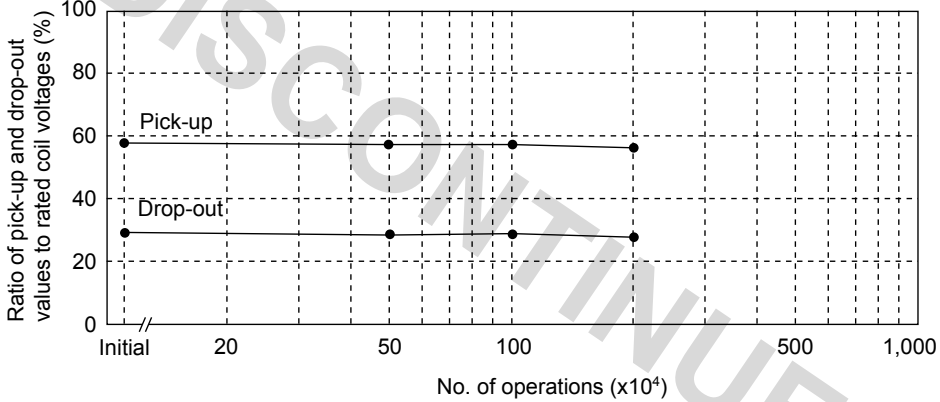

•Shift of contact resistance

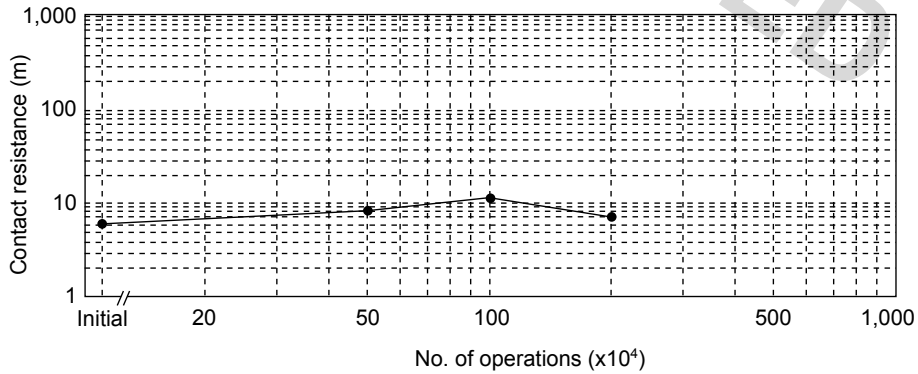

FRL-274 SERIES

LIFE TEST (EXAMPLE)

[Standard type]

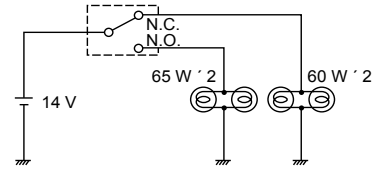
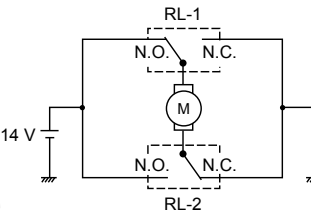
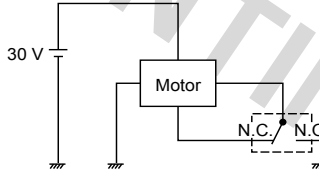
Test Item	Test circuit
N.O. DC 14 V-65 W × 2 N.C. DC 14 V-60 W × 2 Halogen lamp load 500,000 operations minimum (contact material: special silver alloy)	
DC 14 V-30 A Motor lock 100,000 operations minimum (contact material: silver copper)	
DC 30 V-1.6 A Motor free 200,000 operations minimum (contact material: silver copper)	

REFERENCE DATA

[40A type]

Distribution of Operate & Release Voltage

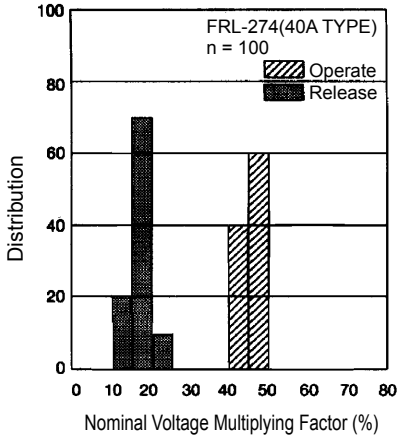

Distribution of Operate & Release Time

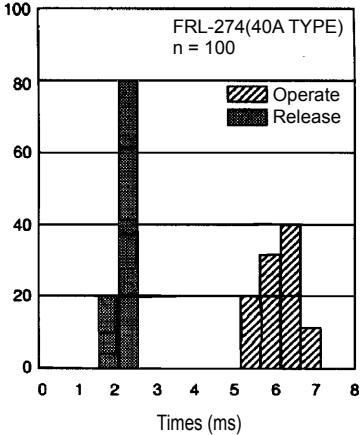

Distribution of Contact Resistance

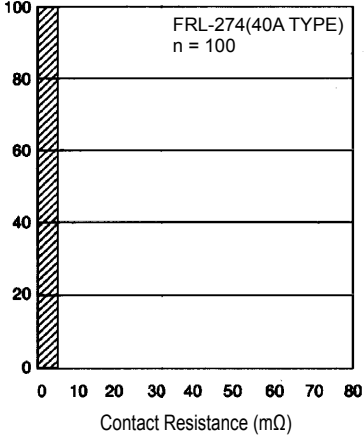

FRL-274 SERIES

REFERENCE DATA

[Standard type]

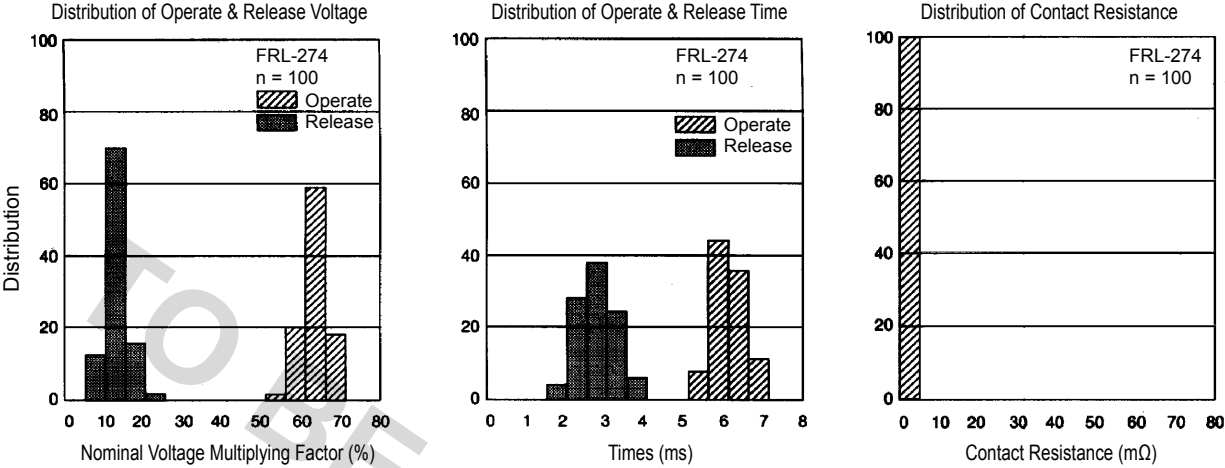

DIMENSIONS

Dimensions

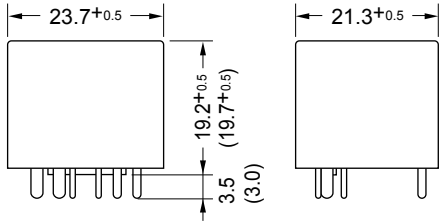

(): N type

PC board mounting hole layout (BOTTOM VIEW)

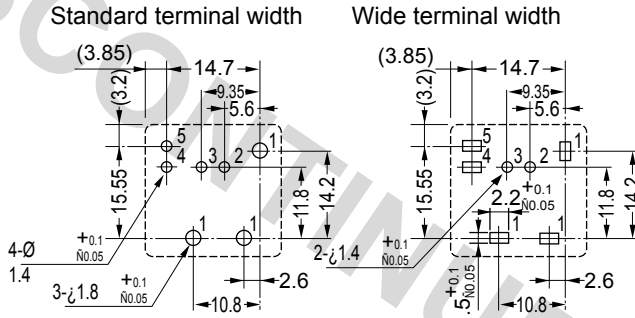

Note : Tolerance ± 0.1 mm
1form A type doesn't have #5 pin.

Schematics (BOTTOM VIEW)

1 form C

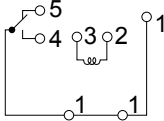

1 form A

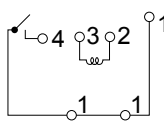

Tube carrier

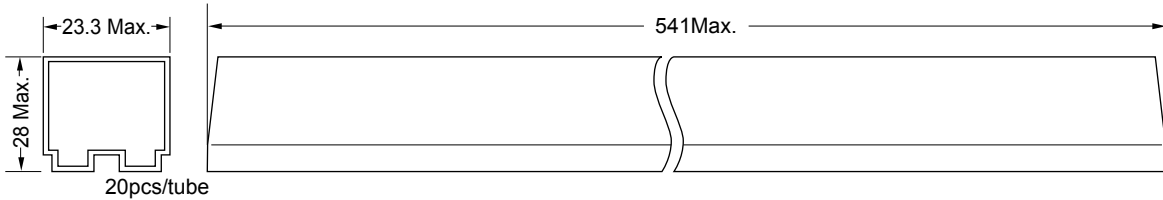

Unit: mm

RoHS Compliance and Lead Free Relay Information

1. General Information

- Relays produced after the specific date code that is indicated on each data sheet are lead-free now. Most of our signal and power relays are lead-free. Please refer to Lead-Free Status Info. (<http://www.fujitsu.com/us/downloads/MICRO/fcai/relays/lead-free-letter.pdf>)
- Lead free solder paste currently used in relays is Sn-3.0Ag-0.5Cu.
- All signal and most power relays also comply with RoHS. Please refer to individual data sheets. Relays that are RoHS compliant do not contain the 5 hazardous materials that are restricted by RoHS directive (lead, mercury, chromium IV, PBB, PBDE).
- It has been verified that using lead-free relays in leaded assembly process will not cause any problems (compatible).
- "LF" is marked on each outer and inner carton. (No marking on individual relays).
- To avoid leaded relays (for lead-free sample, etc.) please consult with area sales office.
- We will ship leaded relays as long as the leaded relay inventory exists.

Note: Cadmium was exempted from RoHS on October 21, 2005. (Amendment to Directive 2002/95/EC)

2. Recommended Lead Free Solder Profile

- Recommended solder paste Sn-3.0Ag-0.5Cu.

Reflow Solder condition

Flow Solder condition:

Pre-heating: maximum 120°C
Soldering: dip within 5 sec. at
260°C solder bath

Solder by Soldering Iron:

Soldering Iron
Temperature: maximum 360°C
Duration: maximum 3 sec.

We highly recommend that you confirm your actual solder conditions

3. Moisture Sensitivity

- Moisture Sensitivity Level standard is not applicable to electromechanical relays.

4. Tin Whisker

- Dipped SnAgCu solder is known as low risk tin whisker. No considerable length whisker was found by our in house test.

Fujitsu Components International Headquarter Offices

Japan

Fujitsu Component Limited
Gotanda-Chuo Building
3-5, Higashigotanda 2-chome, Shinagawa-ku
Tokyo 141 8630, Japan
Tel: (81-3) 5449-7010
Fax: (81-3) 5449-2626
Email: promothq@fcl.fujitsu.com
Web: www.fcl.fujitsu.com

North and South America

Fujitsu Components America, Inc.
250 E. Caribbean Drive
Sunnyvale, CA 94089 U.S.A.
Tel: (1-408) 745-4900
Fax: (1-408) 745-4970
Email: components@us.fujitsu.com
Web: <http://www.fujitsu.com/us/services/edevices/components/>

Europe

Fujitsu Components Europe B.V.
Diamantlaan 25
2132 WV Hoofddorp
Netherlands
Tel: (31-23) 5560910
Fax: (31-23) 5560950
Email: info@fceu.fujitsu.com
Web: emea.fujitsu.com/components/

Asia Pacific

Fujitsu Components Asia Ltd.
102E Pasir Panjang Road
#01-01 Citilink Warehouse Complex
Singapore 118529
Tel: (65) 6375-8560
Fax: (65) 6273-3021
Email: fcals@fcal.fujitsu.com
Web: <http://www.fujitsu.com/sg/services/micro/components/>

©2009 Fujitsu Components America, Inc. All rights reserved. All trademarks or registered trademarks are the property of their respective owners.

Fujitsu Components America or its affiliates do not warrant that the content of datasheet is error free. In a continuing effort to improve our products Fujitsu Components America, Inc. or its affiliates reserve the right to change specifications/datasheets without prior notice.
Rev. June 30, 2009.