



Leaded Oscillator, VCXO, TTL / HC-MOS  
Metal Package, Full Size DIP and Half DIP



I202 / I203 Series

**Product Features:**

CMOS/TTL Compatible Logic Levels  
Low Noise  
Compatible with Leadfree Processing  
RoHS Compliant

**Applications:**

Server & Storage  
Sonet /SDH  
802.11 / Wifi  
T1/E1, T3/E3

<b>Frequency</b>	1 MHz to 51.840 MHz
<b>Output Level</b> HC-MOS TTL	'0' = 0.1 Vcc Max., '1' = 0.9 Vcc Min. '0' = 0.4 VDC Max., '1' = 2.4 VDC Min.
<b>Duty Cycle</b>	50% ±5%
<b>Rise / Fall Time</b>	10 nS Max.*
<b>Output Load</b> HC-MOS TTL	Fo < 50 MHz = 10 TTL, Fo > 50 MHz = 5 LSTTL 15 pF
<b>Frequency Stability</b>	See Frequency Stability Table
<b>Supply Voltage</b>	See Input Voltage Table, tolerance ±10 %
<b>Current</b>	50 mA Max.*
<b>Control Voltage</b>	1.65 VDC ±1.5 VDC for Vcc = 3.3 VDC, 2.5 VDC ±2.0 VDC for VCC = 5.0 VDC
<b>Slope</b>	Positive
<b>Jitter</b>	<1.0 pS RMS (12 kHz to 20 MHz)**
<b>Operating</b>	See Operating Temperature Table in Part Number Guide
<b>Storage</b>	-55° C to +125° C

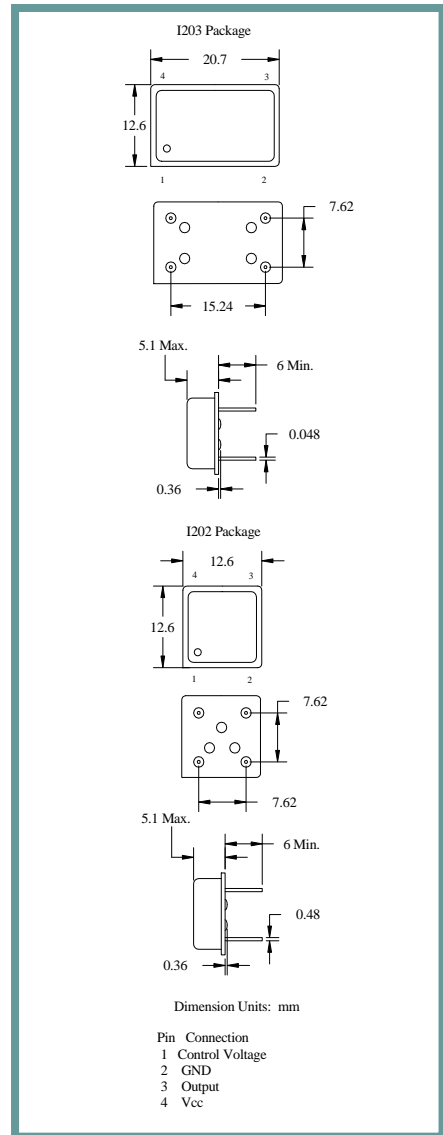

Part Number Guide		Sample Part Number: I202-1BC3-27.000 MHz			
Package	Operating Temperature	Frequency Stability	Pullability	Supply Voltage	Frequency
I202 - I203 -	1 = 0° C to +70° C	F = ±20 ppm	B = ±50 ppm min.	5 = 5.0 VDC	- 27.000 MHz
	3 = -20° C to +70° C	X = ±30 ppm	C = ±100 ppm min.	3 = 3.3 VDC	
	4 = -30° C to +75° C	B = ±50 ppm	K = ±150 ppm min.		
	2 = -40° C to +85° C	C = ±100 ppm	L = ±200 ppm min.		

NOTE: A 0.01 µF bypass capacitor is recommended between Vcc (pin 4) and GND (pin 2) to minimize power supply noise.  
\* Frequency, supply, and load related parameters. Frequency related, for additional information contact your sales representative.



Leaded Oscillator, VCXO, TTL / HC-MOS  
Metal Package, Full Size DIP and Half DIP



I202 / I203 Series

**Pb Free Solder Reflow Profile:**

**Typical Application:**

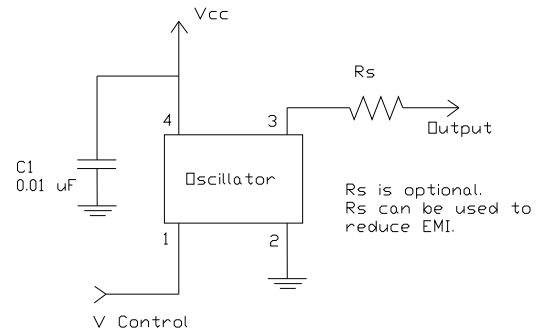
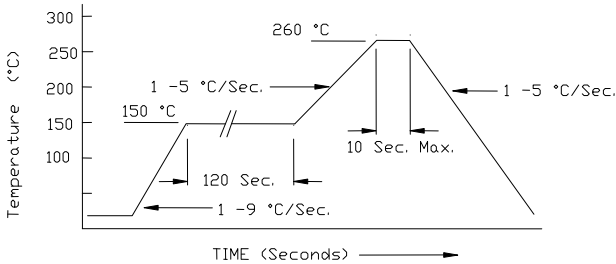

\*Units are backward compatible with 240C reflow processes

**Package Information:**

MSL = N.A. (package does not contain plastic, storage life is unlimited under normal room conditions).  
Termination = e4- (Sn / Cu / Ag over Ni over Kovar base metal).

**Environmental Specifications**

Thermal Shock	MIL-STD-883, Method 1011, Condition A
Moisture Resistance	MIL-STD-883, Method 1004
Mechanical Shock	MIL-STD-883, Method 2002, Condition B
Mechanical Vibration	MIL-STD-883, Method 2007, Condition A
Resistance to Soldering Heat	J-STD-020C, Table 5-2 Pb-free devices (except 2 cycles max)
Hazardous Substance	Pb-Free / RoHS / Green Compliant
Solderability	JESD22-B102-D Method 2 (Preconditioning E)
Terminal Strength	MIL-STD-883, Method 2004, Test Condition D
Gross Leak	MIL-STD-883, Method 1014, Condition C
Fine Leak	MIL-STD-883, Method 1014, Condition A2, R1=2x10 <sup>-8</sup> atm cc/s
Solvent Resistance	MIL-STD-202, Method 215

**Marking**

Line 1: ILSI and Date Code  
Line 2: XXXX (Part Number detail = I203-XXXX-Freq.)  
Line 3: Frequency