

Industrial 16mm Size Slim Conductive Plastic Precision Rotary Sensor

Features

- Compact Size
- Up to 3 Million Life Cycles
- 2% Precision Linearity
- Water Resistant
- Wide Temperature Range
- Solder Lug Terminal
- RoHS Compliant



Electrical and Mechanical Specifications

Resistance Range

1 K through 500 K ohms, linear

Resistance Tolerance

± 10%, ± 20%

Power Rating

0.25 watts @ 55°C

Dielectric Strength

500 VDC for 1 minute

Maximum Operating Voltage

350 VDC

Insulation Resistance

100 Megohms minimum @ 100 VDC

Rotation Angle

Total Rotational Angle : 250°
Effective Electrical Angle : 60°, 220°

Rotational Torque

IP40 : 3~30 gf-cm
IP54 & IP67 : 20~120 gf-cm

Stop Strength

9 kgf-cm minimum

Push-Pull Strength of Shaft

13.6 kg for 10 seconds

Mounting Information

Bushing Mount

Rotational life

3M Cycles (60° Effective Electrical Angle)
2M Cycles (220° Effective Electrical Angle)

Linearity

± 2%

Temperature

Operating : -40°C - 125°C
Storage : -55°C - 150°C

Solder Heat Resistance

350°C for 5 seconds

Ingress Protection Rating

IP40, IP54, IP67

Vibration

15G, 10 to 2000 Hz

284T Metal Shaft, Bushing Mount, Solder Lug Terminal

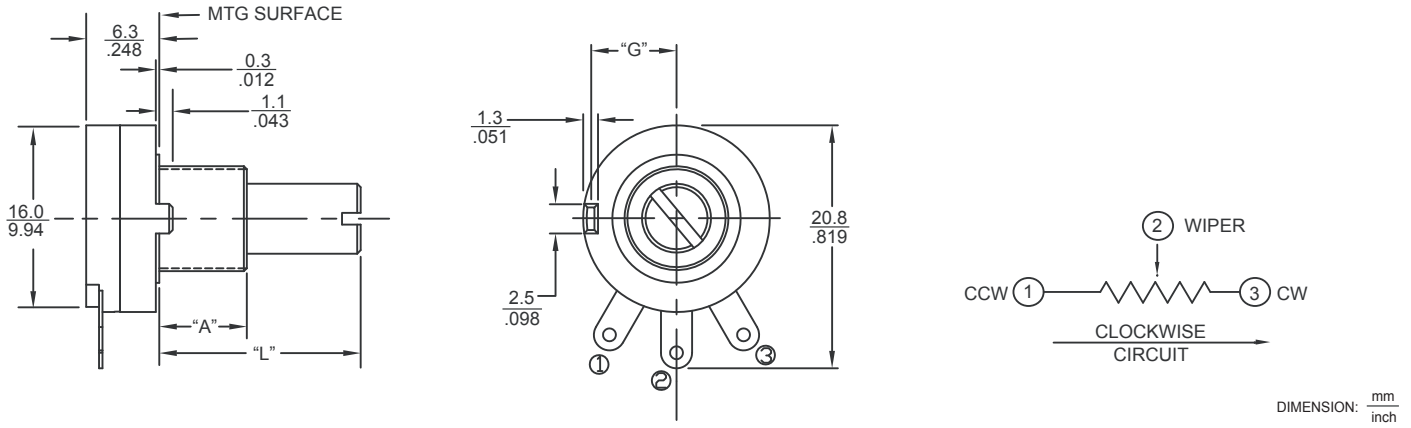

Shaft Trim

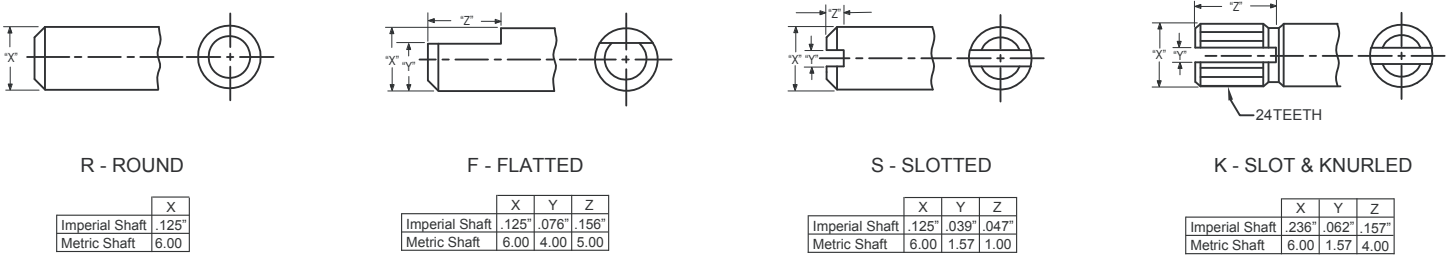

Note: Contact CTS for shaft sizes not listed

Ordering Information

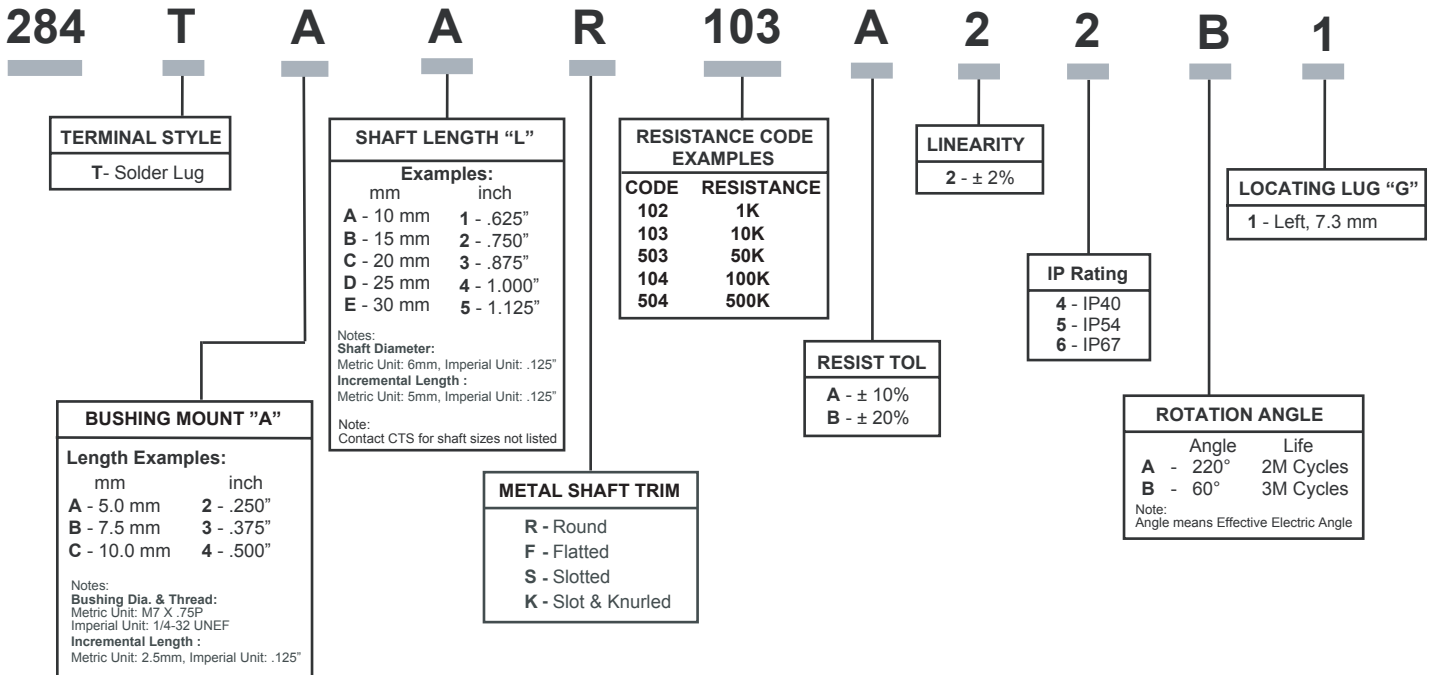

Please consult factory for custom or not listed features.