

N-CHANNEL INSULATED-GATE BIPOLAR TRANSISTOR

High input impedance

High peak current capability

4.5V gate drive

V_{CE} 450V

I_{CP} 150A

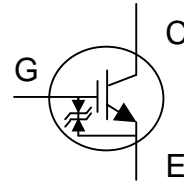
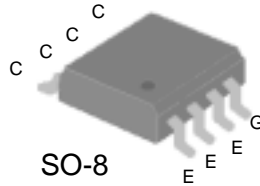

Absolute Maximum Ratings

Symbol	Parameter	Rating	Units
V_{CE}	Collector-Emitter Voltage	450	V
V_{GE}	Gate-Emitter Voltage	± 6	V
V_{GEP}	Pulsed Gate-Emitter Voltage	± 8	V
I_{CP}	Pulsed Collector Current	150	A
$P_D @ T_C=25^\circ C^1$	Maximum Power Dissipation	2.5	W
T_{STG}	Storage Temperature Range	-55 to 150	$^\circ C$
T_J	Operating Junction Temperature Range	-55 to 150	$^\circ C$

Electrical Characteristics @ $T_J=25^\circ C$ (unless otherwise specified)

Symbol	Parameter	Test Conditions	Min.	Typ.	Max.	Units
I_{GES}	Gate-Emitter Leakage Current	$V_{GE}=\pm 6V, V_{CE}=0V$	-	-	10	μA
I_{CES}	Collector-Emitter Leakage Current ($T_J=25^\circ C$)	$V_{CE}=450V, V_{GE}=0V$	-	-	10	μA
$V_{CE(sat)}$	Collector-Emitter Saturation Voltage	$V_{GE}=4.5V, I_{CP}=150A$ (Pulsed)	-	6	8	V
$V_{GE(th)}$	Gate Threshold Voltage	$V_{CE}=V_{GE}, I_C=250\mu A$	0.35	-	1.2	V
Q_g	Total Gate Charge	$I_C=50A$	-	64.5	-	nC
Q_{ge}	Gate-Emitter Charge	$V_{CE}=360V$	-	7	-	nC
Q_{gc}	Gate-Collector Charge	$V_{GE}=5V$	-	30	-	nC
$t_{d(on)}$	Turn-on Delay Time	$V_{CC}=225V$	-	11.5	-	ns
t_r	Rise Time	$I_C=50A$	-	24.5	-	ns
$t_{d(off)}$	Turn-off Delay Time	$R_G=25\Omega$	-	150	-	ns
t_f	Fall Time	$V_{GE}=5V$	-	3.3	-	μs
C_{ies}	Input Capacitance	$V_{GE}=0V$	-	2227	-	pF
C_{oes}	Output Capacitance	$V_{CE}=25V$	-	200	-	pF
C_{res}	Reverse Transfer Capacitance	$f=1.0MHz$	-	79	-	pF
R_{thJA}^1	Thermal Resistance Junction-Ambient		-	-	50	$^\circ C/W$

Notes:

1. Surface mounted on 1 in² copper pad of FR4 board ; 125 $^\circ C/W$ when mounted on min. copper pad.

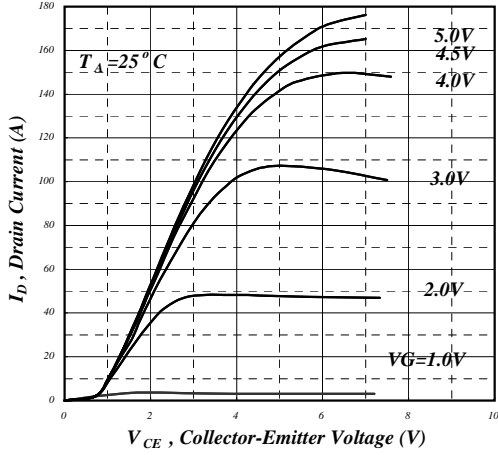

Fig 1. Typical Output Characteristics

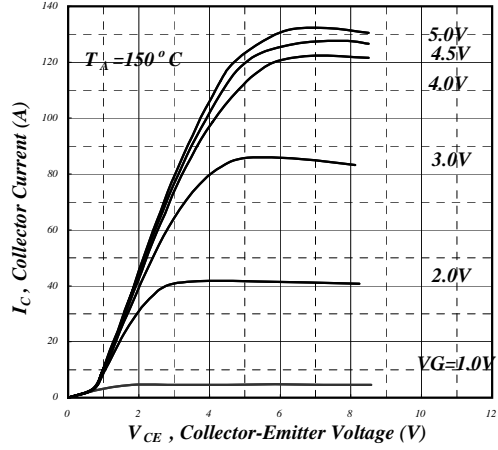

Fig 2. Typical Output Characteristics

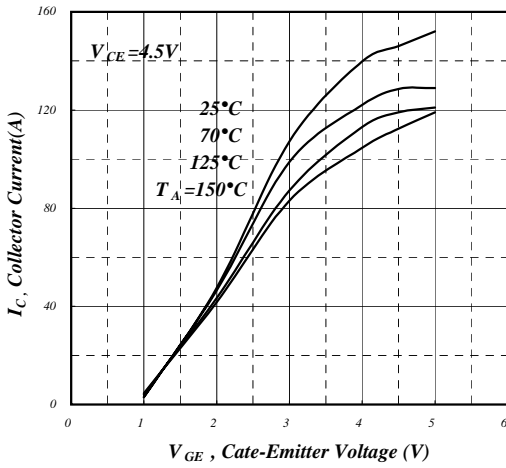

Fig 3. Collector Current vs. Gate-Emitter Voltage

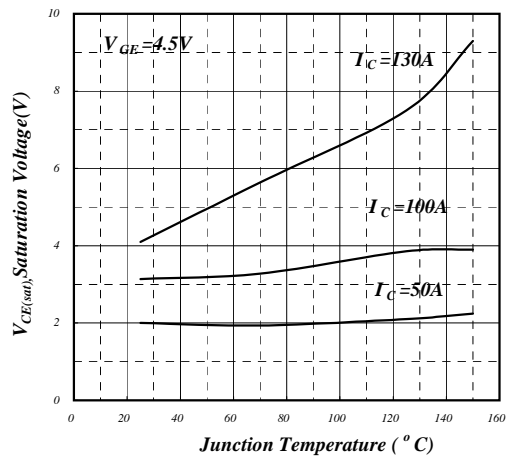

Fig 4. Collector-Emitter Saturation Voltage vs. Junction Temperature

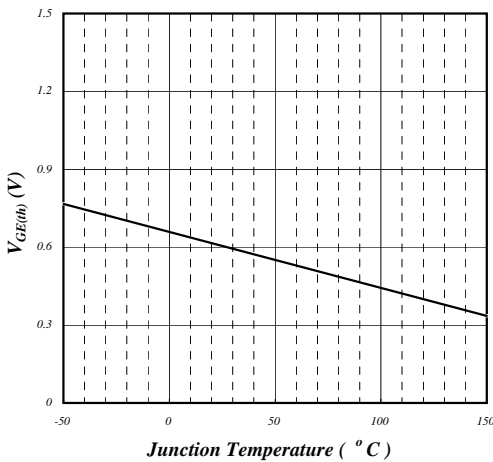

Fig 5. Gate Threshold Voltage vs. Junction Temperature

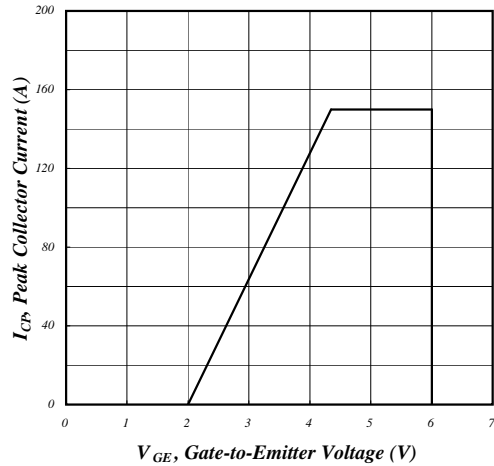

Fig 6. Minimum Gate Drive Area

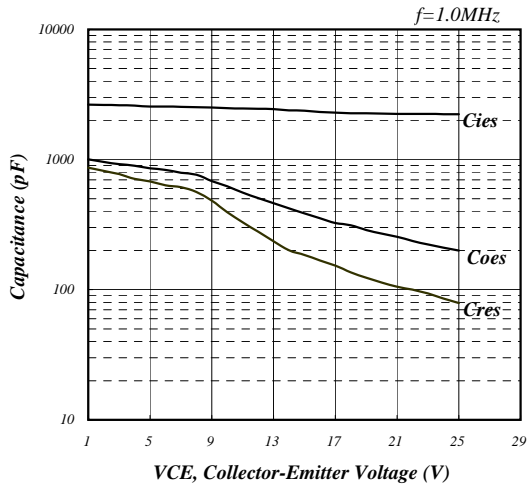

Fig 7. Typical Capacitance Characteristics

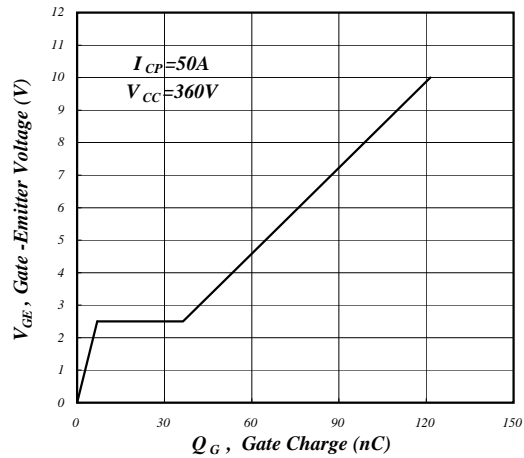

Fig 8. Gate Charge Waveform

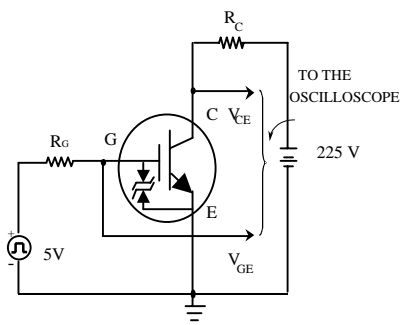

Fig 9. Switching Time Test Circuit

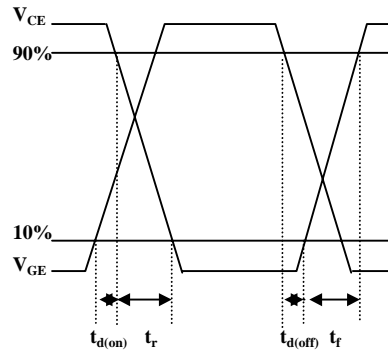

Fig 10. Switching Time Waveform

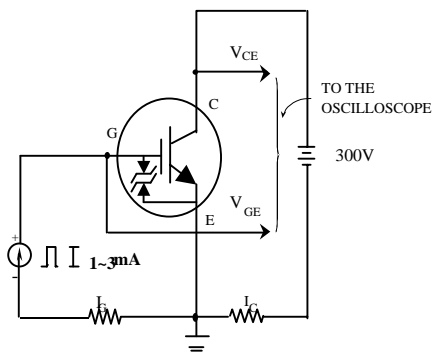

Fig 11. Gate Charge Test Circuit

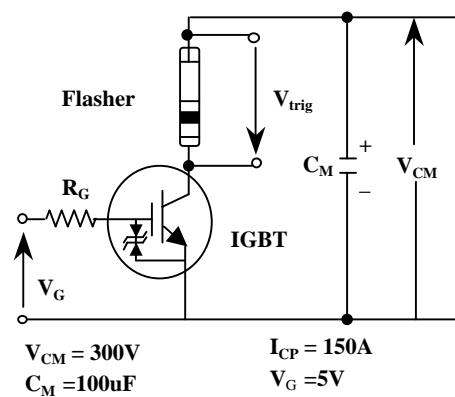

Fig 12. Application Test Circuit

Information furnished by Silicon Standard Corporation is believed to be accurate and reliable. However, Silicon Standard Corporation makes no guarantee or warranty, express or implied, as to the reliability, accuracy, timeliness or completeness of such information and assumes no responsibility for its use, or for infringement of any patent or other intellectual property rights of third parties that may result from its use. Silicon Standard reserves the right to make changes as it deems necessary to any products described herein for any reason, including without limitation enhancement in reliability, functionality or design. No license is granted, whether expressly or by implication, in relation to the use of any products described herein or to the use of any information provided herein, under any patent or other intellectual property rights of Silicon Standard Corporation or any third parties.