

TMS320C6414, TMS320C6415, TMS320C6416 FIXED-POINT DIGITAL SIGNAL PROCESSORS

SPRS146L – FEBRUARY 2001 – REVISED JULY 2004

- **Highest-Performance Fixed-Point Digital Signal Processors (DSPs)**
 - 2-, 1.67-, 1.39-ns Instruction Cycle Time
 - 500-, 600-, 720-MHz Clock Rate
 - Eight 32-Bit Instructions/Cycle
 - Twenty-Eight Operations/Cycle
 - 4000, 4800, 5760 MIPS
 - Fully Software-Compatible With C62x™
 - C6414/15/16 Devices Pin-Compatible
- **VelociTI.2™ Extensions to VelociTI™ Advanced Very-Long-Instruction-Word (VLIW) TMS320C64x™ DSP Core**
 - Eight Highly Independent Functional Units With VelociTI.2™ Extensions:
 - Six ALUs (32-/40-Bit), Each Supports Single 32-Bit, Dual 16-Bit, or Quad 8-Bit Arithmetic per Clock Cycle
 - Two Multipliers Support Four 16 x 16-Bit Multiplies (32-Bit Results) per Clock Cycle or Eight 8 x 8-Bit Multiplies (16-Bit Results) per Clock Cycle
 - Non-Aligned Load-Store Architecture
 - 64 32-Bit General-Purpose Registers
 - Instruction Packing Reduces Code Size
 - All Instructions Conditional
- **Instruction Set Features**
 - Byte-Addressable (8-/16-/32-/64-Bit Data)
 - 8-Bit Overflow Protection
 - Bit-Field Extract, Set, Clear
 - Normalization, Saturation, Bit-Counting
 - VelociTI.2™ Increased Orthogonality
- **Viterbi Decoder Coprocessor (VCP) [C6416]**
 - Supports Over 600 7.95-Kbps AMR
 - Programmable Code Parameters
- **Turbo Decoder Coprocessor (TCP) [C6416]**
 - Supports up to 7 2-Mbps or 43 384-Kbps 3GPP (6 Iterations)
 - Programmable Turbo Code and Decoding Parameters
- **L1/L2 Memory Architecture**
 - 128K-Bit (16K-Byte) L1P Program Cache (Direct Mapped)
 - 128K-Bit (16K-Byte) L1D Data Cache (2-Way Set-Associative)
 - 8M-Bit (1024K-Byte) L2 Unified Mapped RAM/Cache (Flexible Allocation)
- **Two External Memory Interfaces (EMIFs)**
 - One 64-Bit (EMIFA), One 16-Bit (EMIFB)
 - Glueless Interface to Asynchronous Memories (SRAM and EPROM) and Synchronous Memories (SDRAM, SBSRAM, ZBT SRAM, and FIFO)
 - 1280M-Byte Total Addressable External Memory Space
- **Enhanced Direct-Memory-Access (EDMA) Controller (64 Independent Channels)**
- **Host-Port Interface (HPI)**
 - User-Configurable Bus Width (32-/16-Bit)
- **32-Bit/33-MHz, 3.3-V PCI Master/Slave Interface Conforms to PCI Specification 2.2 [C6415/C6416]**
 - Three PCI Bus Address Registers:
 - Prefetchable Memory
 - Non-Prefetchable Memory I/O
 - Four-Wire Serial EEPROM Interface
 - PCI Interrupt Request Under DSP Program Control
 - DSP Interrupt Via PCI I/O Cycle
- **Three Multichannel Buffered Serial Ports**
 - Direct Interface to T1/E1, MVIP, SCSA Framers
 - Up to 256 Channels Each
 - ST-Bus-Switching-, AC97-Compatible
 - Serial Peripheral Interface (SPI) Compatible (Motorola™)
- **Three 32-Bit General-Purpose Timers**
- **Universal Test and Operations PHY Interface for ATM (UTOPIA) [C6415/C6416]**
 - UTOPIA Level 2 Slave ATM Controller
 - 8-Bit Transmit and Receive Operations up to 50 MHz per Direction
 - User-Defined Cell Format up to 64 Bytes
- **Sixteen General-Purpose I/O (GPIO) Pins**
- **Flexible PLL Clock Generator**
- **IEEE-1149.1 (JTAG†) Boundary-Scan-Compatible**
- **532-Pin Ball Grid Array (BGA) Package (GLZ and ZLZ Suffix), 0.8-mm Ball Pitch**
- **0.13-μm/6-Level Cu Metal Process (CMOS)**
- **3.3-V I/Os, 1.2-V/1.25-V Internal (500 MHz)**
- **3.3-V I/Os, 1.4-V Internal (600 and 720 MHz)**



Please be aware that an important notice concerning availability, standard warranty, and use in critical applications of Texas Instruments semiconductor products and disclaimers thereto appears at the end of this data sheet.

C62x, VelociTI.2, VelociTI, and TMS320C64x are trademarks of Texas Instruments.

Motorola is a trademark of Motorola, Inc.

† IEEE Standard 1149.1-1990 Standard-Test-Access Port and Boundary Scan Architecture.

This document contains information on products in more than one phase of development. The status of each device is indicated on the page(s) specifying its electrical characteristics.



POST OFFICE BOX 1443 • HOUSTON, TEXAS 77251-1443

Copyright © 2004 Texas Instruments Incorporated

ADVANCE INFORMATION

TMS320C6414, TMS320C6415, TMS320C6416 FIXED-POINT DIGITAL SIGNAL PROCESSORS

SPRS146L – FEBRUARY 2001 – REVISED JULY 2004

ADVANCE INFORMATION

Table of Contents

| | | | |
|---|----|--|-----|
| revision history | 2 | reset | 78 |
| GLZ and ZLZ BGA packages (bottom view) | 6 | absolute maximum ratings over operating case temperature range | 79 |
| description | 7 | recommended operating conditions | 79 |
| device characteristics | 8 | electrical characteristics over recommended ranges of supply voltage and operating case temperature | 80 |
| device compatibility | 9 | recommended clock and control signal transition behavior | 80 |
| functional block and CPU (DSP core) diagram | 10 | parameter measurement information | 81 |
| CPU (DSP core) description | 11 | input and output clocks | 83 |
| memory map summary | 14 | asynchronous memory timing | 87 |
| peripheral register descriptions | 17 | programmable synchronous interface timing | 91 |
| EDMA channel synchronization events | 30 | synchronous DRAM timing | 96 |
| interrupt sources and interrupt selector | 32 | HOLD/HOLDA timing | 106 |
| signal groups description | 34 | BUSREQ timing | 107 |
| device configurations | 39 | reset timing | 108 |
| multiplexed pins | 43 | external interrupt timing | 110 |
| debugging considerations | 43 | host-port interface (HPI) timing | 111 |
| terminal functions | 45 | peripheral component interconnect (PCI) timing [C6415 and C6416 only] | 116 |
| development support | 65 | multichannel buffered serial port (McBSP) timing | 119 |
| device support | 66 | UTOPIA slave timing [C6415 and C6416 only] | 130 |
| clock PLL | 69 | timer timing | 133 |
| general-purpose input/output (GPIO) | 72 | general-purpose input/output (GPIO) port timing | 134 |
| power-down mode logic | 73 | JTAG test-port timing | 135 |
| power-supply sequencing | 75 | mechanical data | 136 |
| power-supply decoupling | 76 | | |
| IEEE 1149.1 JTAG compatibility statement | 77 | | |
| EMIF device speed | 77 | | |
| bootmode | 78 | | |

REVISION HISTORY

This data sheet revision history highlights the technical changes made to the SPRS146K device-specific data sheet to make it an SPRS146L revision.

Scope: Applicable updates to the C64x device family, specifically relating to the C6414, C6415, and C6416 devices, have been incorporated. Added C6414, C6415, and C6416 silicon revision 2.0 devices and associated device-specific information at the production data (PD) stage of development.

The extended temperature devices for silicon revision 2.0 (C641x A-5E0, C641xA-6E3) are at the advance information (AI) stage of development. All other devices are at the Production Data (PD) stage of development.

| PAGE(S) NO. | ADDITIONS/CHANGES/DELETIONS |
|----------------|---|
| 1 | Features: Changed the Viterbi Decoder Coprocessor (VCP) [C6416] sub-bullet from "Supports Over 500 7.95-Kbps AMR" to "Supports Over 600 7.95-Kbps AMR" Changed the Turbo Decoder Coprocessor (TCP) [C6416] sub-bullet from "Supports up to Six 2-Mbps 3GPP (6 Iterations)" to "Supports up to 7 2-Mbps or 43 384-Kbps 3GPP (6 Iterations)" |
| 7 | Description section: "With performance of up to 5760 million instructions per second (MIPS) ..." paragraph Changed "The C64x can produce four 32-bit multiply-accumulates (MACs) per ..." sentence to "The C64x can produce four 16-bit multiply-accumulates (MACs) per ..." |



TMS320C6414, TMS320C6415, TMS320C6416 FIXED-POINT DIGITAL SIGNAL PROCESSORS

SPRS146L – FEBRUARY 2001 – REVISED JULY 2004

| PAGE(S) NO. | ADDITIONS/CHANGES/DELETIONS |
|----------------|---|
| 7 | <p>Description section: “The C6416 device has two high-performance embedded coprocessors [Viterbi Decoder Coprocessor (VCP) and Turbo Decoder Coprocessor (TCP)] that ...” paragraph Changed “The VCP operating at CPU clock divided-by-4 can decode over 500 7.95-Kbps adaptive multi-rate ...” sentence to “The VCP operating at CPU clock divided-by-4 can decode over 600 7.95-Kbps adaptive multi-rate ...”</p> <p>Changed “The TCP operating at CPU clock divided-by-2 can decode up to thirty-six 384-Kbps or six 2-Mbps turbo encoded channels ...” sentence to “The TCP operating at CPU clock divided-by-2 can decode up to forty-three 384-Kbps or seven 2-Mbps turbo encoded channels ...”</p> |
| 16 | <p>L2 architecture expanded section: Added <i>new</i> section Added Figure 2, TMS320C6414/C6415/C6416 L2 Architecture Memory Configuration</p> |
| 18 | <p>Peripheral register descriptions section: Table 6, L2 Cache Registers: Updated the “ACRONYM” and “REGISTER NAME” columns for the “0184 4000 through 0184 5004” HEX ADDRESS RANGE Added rows “0184 4018” and “0184 401C” Changed the “0184 4038 – 0184 4FFC” HEX ADDRESS RANGE for the “Reserved” row to “0184 4038 – 0184 4044” Added rows “0184 4048” and “0184 404C” Added “Reserved” row “0184 4050 – 0184 4FFC”</p> |
| 22 | <p>Peripheral register descriptions section: EDMA Parameter RAM table: Updated associated table footnote from “The C64x device ...” to “The C6414/C6415/C6416 device ...”</p> |
| 66 | <p>Added “device support” section title (<i>new</i>)</p> |
| 66–67 | <p>Device and development-support tool nomenclature section: Updated/changed “Table 30 displays the device part numbers and ordering information for ...” paragraph Deleted Table 30, TMS320C6414/C6415/C6416 Device Part Numbers (P/Ns) and Ordering Information Deleted the “TMX and TMP devices and TMDX development-support tools are shipped with ...” paragraph</p> <p>Figure 5, TMS320C64x™ DSP Device Nomenclature (Including the C6414, C6415, and C6416 Devices): Updated/changed the “For the actual device part numbers (P/Ns) and ordering information, ...” footnote</p> <p>Added, below Figure 5, “For additional information, see the <i>TMS320C6414</i>, <i>TMS320C6415</i>, and <i>TMS320C6416 Digital Signal Processors Silicon Errata</i> (literature number SPRZ011)” paragraph (<i>new</i>)</p> |
| 68 | <p>Documentation support section: Updated/moved the “<i>How To Begin Development Today With the TMS320C6414, TMS320C6415, and TMS320C6416 DSPs application report (literature number SPRA718)</i>” document reference</p> |
| 76 | <p>Power-supply decoupling section: Updated/changed the “In order to properly decouple the supply planes from system noise, place as many capacitors ...” paragraph Added two subsequent paragraphs</p> |
| 78 | <p>Reset section: Added <i>new</i> section</p> |
| 77 | <p>IEEE 1149.1 JTAG compatibility statement section: Updated/added paragraphs for clarity</p> |

ADVANCE INFORMATION



TMS320C6414, TMS320C6415, TMS320C6416 FIXED-POINT DIGITAL SIGNAL PROCESSORS

SPRS146L – FEBRUARY 2001 – REVISED JULY 2004

ADVANCE INFORMATION

| PAGE(S) NO. | ADDITIONS/CHANGES/DELETIONS |
|----------------|--|
| 87–88 | <p>Asynchronous Memory Timing section: Timing Requirements for Asynchronous Memory Cycles for EMIFA Module table: Added/split silicon revisions “Rev 1.1 and earlier” and “Rev 2.0” for the MIN value of parameter #7 “$t_h(\text{EKO1H-ARDY})$, Hold time, ARDY valid after ECLKOUTx high” Added under the “–5E0, –6E3, –7E3” column, the MIN value of “1.3” ns for “Rev 2.0”</p> <p>Timing Requirements for Asynchronous Memory Cycles for EMIFB Module table: Added/split silicon revisions “Rev 1.1 and earlier” and “Rev 2.0” for the MIN value of parameter #7 “$t_h(\text{EKO1H-ARDY})$, Hold time, ARDY valid after ECLKOUTx high” Added under the “–5E0, –6E3, –7E3” column, the MIN value of “1.3” ns for “Rev 2.0”</p> |
| 106 | <p><u>HOLD/HOLDA</u> Timing section: Timing Requirements for the <u>HOLD/HOLDA</u> Cycles for EMIFA and EMIFB modules table: Changed parameter NO. 3 from “$t_{oh}(\text{HOLDAL-HOLDL})$” to “$t_h(\text{HOLDAL-HOLDL})$”</p> |
| 108 | <p>Reset Timing section: Timing Requirements for Reset table: Changed the MIN value of parameter No. 16, $t_{su}(\text{boot})$ from “4P” to “4E or 4C” ns Added associated footnote to identify “E” and “C” Added parameter NO. 18, “$t_d(\text{PCLK-RSTH})$ Delay time, PCLK active to <u>RESET</u> high” with a MIN value of “32N” ns Changed parameter NO. 18 description from “$t_d(\text{PCLK-RSTH})$ Delay time, PCLK active to <u>RESET</u> high” to “$t_{su}(\text{PCLK-RSTH})$, Setup time, PCLK active before <u>RESET</u> high” Added associated footnote to identify “N” and restraints</p> <p>Switching Characteristics Over Recommended Operating Conditions During Reset table: Moved parameter NO. 18, “$t_d(\text{PCLK-RSTH})$ Delay time, PCLK active to <u>RESET</u> high” to the Timing Requirements for Reset table Updated footnote symbols</p> |
| 111 | <p>Host-Port Interface (HPI) Timing section: Switching Characteristics Over Recommended Operating Conditions During Host-Port Interface Cycles table: Added “mode, 2nd half-word” to parameter NO. 16 “$t_d(\text{HSTBL-HDV})$, Delay time, HSTROBE low to HD valid (HPI16 only)”</p> |
| 118 | <p>Peripheral Component Interconnect (PCI) Timing [C6415 AND C6416 ONLY] section: Switching Characteristics Over Recommended Operating Conditions for Serial EEPROM Interface table: Changed parameter NO. 6 description from “$t_{osu}(\text{DOV-CLKH})$, Output setup time, XSP_DO valid after XSP_CLK high” to “$t_{osu}(\text{DOV-CLKH})$, Output setup time, XSP_DO valid before XSP_CLK high”</p> |
| 120–121 | <p>Multichannel Buffered Serial Port (McBSP) Timing section: Switching Characteristics Over Recommended Operating Conditions for McBSP table: Changed the MIN value of parameter #12 “$t_{dis}(\text{CKXH-DXHZ})$, Disable time, DX high impedance following last data bit from CLKX high, CLKX ext” from “–2.1” to “2.0” ns Changed the MIN value of parameter #13 “$t_d(\text{CKXH-DXV})$, Delay time, CLKX high to DX valid, CLKX ext” from “–2.1 + D1” to “2.0 + D1” ns Changed the MIN value of parameter #14 “$t_d(\text{FXH-DXV})$, Delay time, FSX high to DX valid, FSX int” from “–2.3” to “–2.3 + D1” ns Changed the MAX value of parameter #14 “$t_d(\text{FXH-DXV})$, Delay time, FSX high to DX valid, FSX int” from “5.6” to “5.6 + D2” ns Changed the MIN value of parameter #14 “$t_d(\text{FXH-DXV})$, Delay time, FSX high to DX valid, FSX ext” from “1.9” to “1.9 + D1” ns Changed the MAX value of parameter #14 “$t_d(\text{FXH-DXV})$, Delay time, FSX high to DX valid, FSX ext” from “9” to “9 + D2” ns Added associated footnote</p> <p>Figure 51, McBSP Timing: Added footnote for clarity</p> |



TMS320C6414, TMS320C6415, TMS320C6416 FIXED-POINT DIGITAL SIGNAL PROCESSORS

SPRS146L – FEBRUARY 2001 – REVISED JULY 2004

| PAGE(S) NO. | ADDITIONS/CHANGES/DELETIONS |
|----------------|---|
| 134 | General-Purpose Input/Output (GPIO) Port Timing section: Switching Characteristics Over Recommended Operating Conditions for GPIO Outputs table: Changed the MIN value of parameter #3 " $t_w(\text{GPOH})$, Pulse duration, GPOx high" from "32P" to "24P – 8" ns Changed the MIN value of parameter #4 " $t_w(\text{GPOL})$, Pulse duration, GPOx low" from "32P" to "24P – 8" ns Added associated footnote |
| 136 | Mechanical Data section: Deleted the " GLZ and ZLZ (S-PBGA-N532), PLASTIC BALL GRID ARRAY" mechanical data package diagram; now an automated merged process Added the "thermal resistance characteristics (S-PBGA package) [ZLZ]" table Added lead-in sentence for the thermal resistance characteristics table(s) and the "merged" mechanical data packages |

ADVANCE INFORMATION



TMS320C6414, TMS320C6415, TMS320C6416 FIXED-POINT DIGITAL SIGNAL PROCESSORS

SPRS146L – FEBRUARY 2001 – REVISED JULY 2004

GLZ and ZLZ BGA packages (bottom view)

GLZ and ZLZ 532-PIN BALL GRID ARRAY (BGA) PACKAGE
(BOTTOM VIEW)†

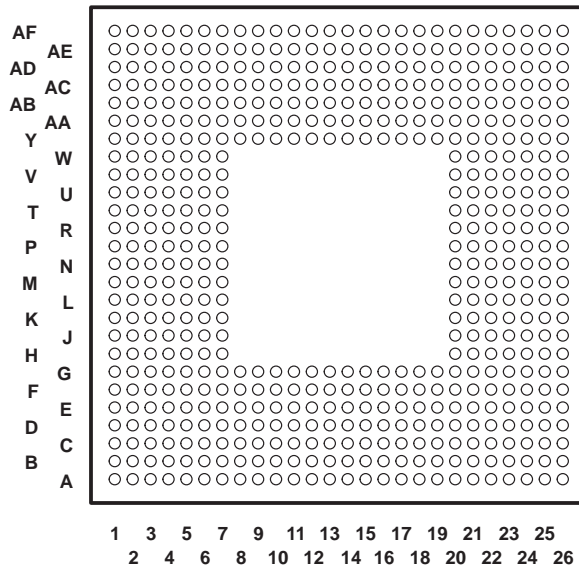

† The ZLZ mechanical package designator represents the version of the GLZ package with lead-free balls. For more detailed information see the *Mechanical Data* section of this document.

ADVANCE INFORMATION

description

The TMS320C64x™ DSPs (including the TMS320C6414, TMS320C6415, and TMS320C6416 devices) are the highest-performance fixed-point DSP generation in the TMS320C6000™ DSP platform. The TMS320C64x™ (C64x™†) device is based on the second-generation high-performance, advanced VelociTI™ very-long-instruction-word (VLIW) architecture (VelociTI.2™) developed by Texas Instruments (TI), making these DSPs an excellent choice for multichannel and multifunction applications. The C64x™ is a code-compatible member of the C6000™ DSP platform.

With performance of up to 5760 million instructions per second (MIPS) at a clock rate of 720 MHz, the C64x devices offer cost-effective solutions to high-performance DSP programming challenges. The C64x DSPs possess the operational flexibility of high-speed controllers and the numerical capability of array processors. The C64x™ DSP core processor has 64 general-purpose registers of 32-bit word length and eight highly independent functional units—two multipliers for a 32-bit result and six arithmetic logic units (ALUs)—with VelociTI.2™ extensions. The VelociTI.2™ extensions in the eight functional units include new instructions to accelerate the performance in key applications and extend the parallelism of the VelociTI™ architecture. The C64x can produce four 16-bit multiply-accumulates (MACs) per cycle for a total of 2880 million MACs per second (MMACS), or eight 8-bit MACs per cycle for a total of 5760 MMACS. The C64x DSP also has application-specific hardware logic, on-chip memory, and additional on-chip peripherals similar to the other C6000™ DSP platform devices.

The C6416 device has two high-performance embedded coprocessors [Viterbi Decoder Coprocessor (VCP) and Turbo Decoder Coprocessor (TCP)] that significantly speed up channel-decoding operations on-chip. The VCP operating at CPU clock divided-by-4 can decode over 600 7.95-Kbps adaptive multi-rate (AMR) [K = 9, R = 1/3] voice channels. The VCP supports constraint lengths K = 5, 6, 7, 8, and 9, rates R = 1/2, 1/3, and 1/4, and flexible polynomials, while generating hard decisions or soft decisions. The TCP operating at CPU clock divided-by-2 can decode up to forty-three 384-Kbps or seven 2-Mbps turbo encoded channels (assuming 6 iterations). The TCP implements the max*log-map algorithm and is designed to support all polynomials and rates required by Third-Generation Partnership Projects (3GPP and 3GPP2), with fully programmable frame length and turbo interleaver. Decoding parameters such as the number of iterations and stopping criteria are also programmable. Communications between the VCP/TCP and the CPU are carried out through the EDMA controller.

The C64x uses a two-level cache-based architecture and has a powerful and diverse set of peripherals. The Level 1 program cache (L1P) is a 128-Kbit direct mapped cache and the Level 1 data cache (L1D) is a 128-Kbit 2-way set-associative cache. The Level 2 memory/cache (L2) consists of an 8-Mbit memory space that is shared between program and data space. L2 memory can be configured as mapped memory or combinations of cache (up to 256K bytes) and mapped memory. The peripheral set includes three multichannel buffered serial ports (McBSPs); an 8-bit Universal Test and Operations PHY Interface for Asynchronous Transfer Mode (ATM) Slave [UTOPIA Slave] port (C6415/C6416 only); three 32-bit general-purpose timers; a user-configurable 16-bit or 32-bit host-port interface (HPI16/HPI32); a peripheral component interconnect (PCI) [C6415/C6416 only]; a general-purpose input/output port (GPIO) with 16 GPIO pins; and two glueless external memory interfaces (64-bit EMIFA and 16-bit EMIFB‡), both of which are capable of interfacing to synchronous and asynchronous memories and peripherals.

The C64x has a complete set of development tools which includes: an advanced C compiler with C64x-specific enhancements, an assembly optimizer to simplify programming and scheduling, and a Windows™ debugger interface for visibility into source code execution.

TMS320C6000, C64x, and C6000 are trademarks of Texas Instruments.

Windows is a registered trademark of the Microsoft Corporation.

All trademarks are the property of their respective owners.

† Throughout the remainder of this document, the TMS320C6414, TMS320C6415, and TMS320C6416 shall be referred to as TMS320C64x or C64x where generic, and where specific, their individual full device part numbers will be used or abbreviated as C6414, C6415, or C6416.

‡ These C64x™ devices have two EMIFs (64-bit EMIFA and 16-bit EMIFB). The prefix "A" in front of a signal name indicates it is an EMIFA signal whereas a prefix "B" in front of a signal name indicates it is an EMIFB signal. Throughout the rest of this document, in generic EMIF areas of discussion, the prefix "A" or "B" may be omitted from the signal name.

TMS320C6414, TMS320C6415, TMS320C6416 FIXED-POINT DIGITAL SIGNAL PROCESSORS

SPRS146L – FEBRUARY 2001 – REVISED JULY 2004

device characteristics

Table 1 provides an overview of the C6414, C6415, and C6416 DSPs. The table shows significant features of the C64x devices, including the capacity of on-chip RAM, the peripherals, the CPU frequency, and the package type with pin count.

Table 1. Characteristics of the C6414, C6415, and C6416 Processors

| HARDWARE FEATURES | | C6414, C6415, AND C6416 | | | | | | | | | | |
|---|--|--|-------------------|------------------|------|-----------------|------|------|--------------|-----|------|-----|
| Peripherals Not all peripherals pins are available at the same time. (For more details, see the Device Configuration section.) Peripheral performance is dependent on chip-level configuration. | EMIFA (64-bit bus width) (default clock source = AECLKIN) | 1 | | | | | | | | | | |
| | EMIFB (16-bit bus width) (default clock source = BECLKIN) | 1 | | | | | | | | | | |
| | EDMA (64 independent channels) | 1 | | | | | | | | | | |
| | HPI (32- or 16-bit user selectable) | 1 (HPI16 or HPI32) | | | | | | | | | | |
| | PCI (32-bit) [DeviceID Register value 0xA106] | 1 [C6415/C6416 only] | | | | | | | | | | |
| | McBSPs (default internal clock source = CPU/4 clock frequency) | 3 | | | | | | | | | | |
| | UTOPiA (8-bit mode) | 1 [C6415/C6416 only] | | | | | | | | | | |
| | 32-Bit Timers (default internal clock source = CPU/8 clock frequency) | 3 | | | | | | | | | | |
| | General-Purpose Input/Output 0 (GP0) | 16 | | | | | | | | | | |
| Decoder Coprocessors | VCP | 1 (C6416 only) | | | | | | | | | | |
| | TCP | 1 (C6416 only) | | | | | | | | | | |
| On-Chip Memory | Size (Bytes) | 1056K | | | | | | | | | | |
| | Organization | 16K-Byte (16KB) L1 Program (L1P) Cache 16KB L1 Data (L1D) Cache 1024KB Unified Mapped RAM/Cache (L2) | | | | | | | | | | |
| CPU ID + CPU Rev ID | Control Status Register (CSR.[31:16]) | 0x0C01 | | | | | | | | | | |
| Device_ID | Silicon Revision Identification Register (DEVICE_REV [19:16]) Address: 0x01B0 0200 | <table border="0"> <tr> <td>DEVICE_REV[19:16]</td> <td>Silicon Revision</td> </tr> <tr> <td>1111</td> <td>1.03 or earlier</td> </tr> <tr> <td>0001</td> <td>1.03</td> </tr> <tr> <td>0010 or 0000</td> <td>1.1</td> </tr> <tr> <td>0011</td> <td>2.0</td> </tr> </table> | DEVICE_REV[19:16] | Silicon Revision | 1111 | 1.03 or earlier | 0001 | 1.03 | 0010 or 0000 | 1.1 | 0011 | 2.0 |
| DEVICE_REV[19:16] | Silicon Revision | | | | | | | | | | | |
| 1111 | 1.03 or earlier | | | | | | | | | | | |
| 0001 | 1.03 | | | | | | | | | | | |
| 0010 or 0000 | 1.1 | | | | | | | | | | | |
| 0011 | 2.0 | | | | | | | | | | | |
| Frequency | MHz | 500, 600, 720 | | | | | | | | | | |
| Cycle Time | ns | 2 ns (C6414-5E0, C6415-5E0, C6416-5E0) and (C6414A-5E0, C6415A-5E0, C6416A-5E0) [500-MHz CPU, 100-MHz EMIF]† 1.67 ns (C6414-6E3, C6415-6E3, C6416-6E3) and (C6414A-6E3, C6415A-6E3, C6416A-6E3) [600-MHz CPU, 133-MHz EMIFA]† 1.39 ns (C6414-7E3, C6415-7E3, C6416-7E3) [720-MHz CPU, 133-MHz EMIFA]† | | | | | | | | | | |
| Voltage | Core (V) | 1.2 V (-5E0) 1.25 V (A-5E0) 1.4 V (-6E3, A-6E3, -7E3) | | | | | | | | | | |
| | I/O (V) | 3.3 V | | | | | | | | | | |
| PLL Options | CLKIN frequency multiplier | Bypass (x1), x6, x12 | | | | | | | | | | |
| BGA Package | 23 x 23 mm | 532-Pin BGA (GLZ and ZLZ) | | | | | | | | | | |
| Process Technology | µm | 0.13 µm | | | | | | | | | | |
| Product Status | Product Preview (PP), Advance Information (AI), Production Data (PD) | PD, AI‡ | | | | | | | | | | |

† On these C64x™ devices, the rated EMIF speed affects only the SDRAM interface on EMIFA. For more detailed information, see the EMIF Device Speed section of this data sheet.

‡ The extended temperature devices for silicon revision 2.0 (C641x A-5E0, C641xA-6E3) are at the advance information (AI) stage of development. All other devices are at the Production Data (PD) stage of development.

ADVANCE INFORMATION



device compatibility

The C64x™ generation of devices has a diverse and powerful set of peripherals. The common peripheral set and pin-compatibility that the C6414, C6415, and C6416 devices offer lead to easier system designs and faster time to market. Table 2 identifies the peripherals and coprocessors that are available on the C6414, C6415, and C6416 devices.

The C6414, C6415, and C6416 devices are pin-for-pin compatible, provided the following conditions are met:

- All devices are using the same peripherals.
The C6414 is pin-for-pin compatible with the C6415/C6416 when the PCI and UTOPIA peripherals on the C6415/C6416 are disabled.
The C6415 is pin-for-pin compatible with the C6416 when they are in the same peripheral selection mode. [For more information on peripheral selection, see the Device Configurations section of this data sheet.]
- The BEA[9:7] pins are properly pulled up/down.
[For more details on the device-specific BEA[9:7] pin configurations, see the Terminal Functions table of this data sheet.]

Table 2. Peripherals and Coprocessors Available on the C6414, C6415, and C6416 Devices†‡

| PERIPHERALS/COPROCESSORS | C6414 | C6415 | C6416 |
|--|-------|-------|-------|
| EMIFA (64-bit bus width) | √ | √ | √ |
| EMIFB (16-bit bus width) | √ | √ | √ |
| EDMA (64 independent channels) | √ | √ | √ |
| HPI (32- or 16-bit user selectable) | √ | √ | √ |
| PCI (32-bit) [Specification v2.2] | — | √ | √ |
| McBSPs (McBSP0, McBSP1, McBSP2) | √ | √ | √ |
| UTOPIA (8-bit mode) [Specification v1.0] | — | √ | √ |
| Timers (32-bit) [TIMER0, TIMER1, TIMER2] | √ | √ | √ |
| GPIOs (GP[15:0]) | √ | √ | √ |
| VCP/TCP Coprocessors | — | — | √ |

† — denotes peripheral/coprocessor is *not* available on this device.

‡ Not all peripherals pins are available at the same time. (For more details, see the Device Configuration section.)

For more detailed information on the device compatibility and similarities/differences among the C6414, C6415, and C6416 devices, see the *How To Begin Development Today With the TMS320C6414, TMS320C6415, and TMS320C6416 DSPs* application report (literature number SPRA718).

ADVANCE INFORMATION

TMS320C6414, TMS320C6415, TMS320C6416 FIXED-POINT DIGITAL SIGNAL PROCESSORS

SPRS146L – FEBRUARY 2001 – REVISED JULY 2004

functional block and CPU (DSP core) diagram

ADVANCE INFORMATION

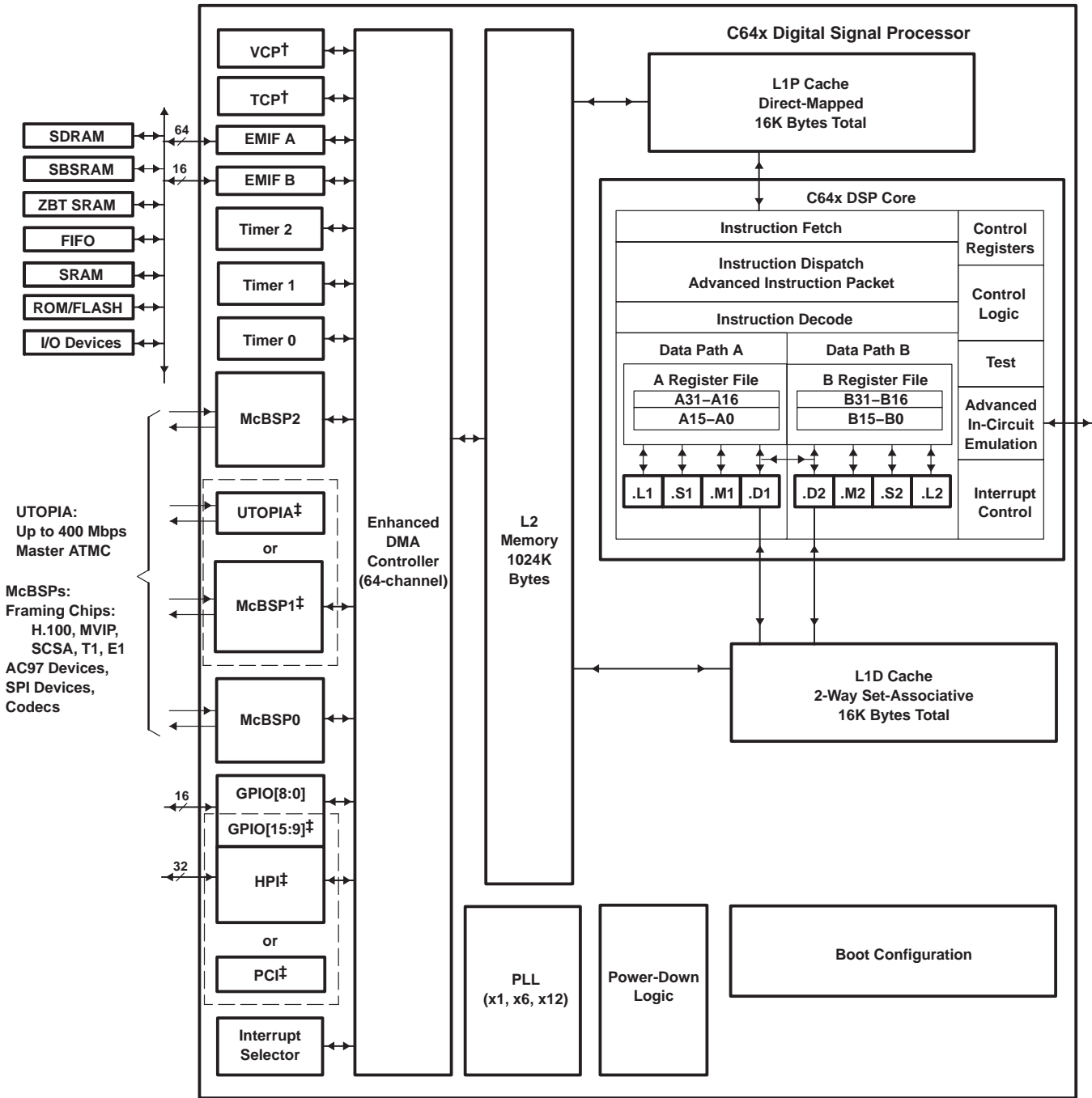

† VCP and TCP decoder coprocessors are applicable to the C6416 device only.

‡ For the C6415 and C6416 devices, the UTOPIA peripheral is muxed with McBSP1, and the PCI peripheral is muxed with the HPI peripheral and the GPIO[15:9] port. For more details on the multiplexed pins of these peripherals, see the Device Configurations section of this data sheet.

CPU (DSP core) description

The CPU fetches VelociTI™ advanced very-long instruction words (VLIWs) (256 bits wide) to supply up to eight 32-bit instructions to the eight functional units during every clock cycle. The VelociTI™ VLIW architecture features controls by which all eight units do not have to be supplied with instructions if they are not ready to execute. The first bit of every 32-bit instruction determines if the next instruction belongs to the same execute packet as the previous instruction, or whether it should be executed in the following clock as a part of the next execute packet. Fetch packets are always 256 bits wide; however, the execute packets can vary in size. The variable-length execute packets are a key memory-saving feature, distinguishing the C64x CPUs from other VLIW architectures. The C64x™ VelociTI.2™ extensions add enhancements to the TMS320C62x™ DSP VelociTI™ architecture. These enhancements include:

- Register file enhancements
- Data path extensions
- Quad 8-bit and dual 16-bit extensions with data flow enhancements
- Additional functional unit hardware
- Increased orthogonality of the instruction set
- Additional instructions that reduce code size and increase register flexibility

The CPU features two sets of functional units. Each set contains four units and a register file. One set contains functional units .L1, .S1, .M1, and .D1; the other set contains units .D2, .M2, .S2, and .L2. The two register files each contain 32 32-bit registers for a total of 64 general-purpose registers. In addition to supporting the packed 16-bit and 32-/40-bit fixed-point data types found in the C62x™ VelociTI™ VLIW architecture, the C64x™ register files also support packed 8-bit data and 64-bit fixed-point data types. The two sets of functional units, along with two register files, compose sides A and B of the CPU [see the functional block and CPU (DSP core) diagram, and Figure 1]. The four functional units on each side of the CPU can freely share the 32 registers belonging to that side. Additionally, each side features a “data cross path”—a single data bus connected to all the registers on the other side, by which the two sets of functional units can access data from the register files on the opposite side. The C64x CPU pipelines data-cross-path accesses over multiple clock cycles. This allows the same register to be used as a data-cross-path operand by multiple functional units in the same execute packet. All functional units in the C64x CPU can access operands via the data cross path. Register access by functional units on the same side of the CPU as the register file can service all the units in a single clock cycle. On the C64x CPU, a delay clock is introduced whenever an instruction attempts to read a register via a data cross path if that register was updated in the previous clock cycle.

In addition to the C62x™ DSP fixed-point instructions, the C64x™ DSP includes a comprehensive collection of quad 8-bit and dual 16-bit instruction set extensions. These VelociTI.2™ extensions allow the C64x CPU to operate directly on packed data to streamline data flow and increase instruction set efficiency.

Another key feature of the C64x CPU is the load/store architecture, where all instructions operate on registers (as opposed to data in memory). Two sets of data-addressing units (.D1 and .D2) are responsible for all data transfers between the register files and the memory. The data address driven by the .D units allows data addresses generated from one register file to be used to load or store data to or from the other register file. The C64x .D units can load and store bytes (8 bits), half-words (16 bits), and words (32 bits) with a single instruction. And with the new data path extensions, the C64x .D unit can load and store doublewords (64 bits) with a single instruction. Furthermore, the non-aligned load and store instructions allow the .D units to access words and doublewords on any byte boundary. The C64x CPU supports a variety of indirect addressing modes using either linear- or circular-addressing with 5- or 15-bit offsets. All instructions are conditional, and most can access any one of the 64 registers. Some registers, however, are singled out to support specific addressing modes or to hold the condition for conditional instructions (if the condition is not automatically “true”).

TMS320C62x is a trademark of Texas Instruments.



TMS320C6414, TMS320C6415, TMS320C6416 FIXED-POINT DIGITAL SIGNAL PROCESSORS

SPRS146L – FEBRUARY 2001 – REVISED JULY 2004

CPU (DSP core) description (continued)

The two .M functional units perform all multiplication operations. Each of the C64x .M units can perform two 16×16 -bit multiplies or four 8×8 -bit multiplies per clock cycle. The .M unit can also perform 16×32 -bit multiply operations, dual 16×16 -bit multiplies with add/subtract operations, and quad 8×8 -bit multiplies with add operations. In addition to standard multiplies, the C64x .M units include bit-count, rotate, Galois field multiplies, and bidirectional variable shift hardware.

The two .S and .L functional units perform a general set of arithmetic, logical, and branch functions with results available every clock cycle. The arithmetic and logical functions on the C64x CPU include single 32-bit, dual 16-bit, and quad 8-bit operations.

The processing flow begins when a 256-bit-wide instruction fetch packet is fetched from a program memory. The 32-bit instructions destined for the individual functional units are “linked” together by “1” bits in the least significant bit (LSB) position of the instructions. The instructions that are “chained” together for simultaneous execution (up to eight in total) compose an execute packet. A “0” in the LSB of an instruction breaks the chain, effectively placing the instructions that follow it in the next execute packet. A C64x™ DSP device enhancement now allows execute packets to cross fetch-packet boundaries. In the TMS320C62x™/TMS320C67x™ DSP devices, if an execute packet crosses the fetch-packet boundary (256 bits wide), the assembler places it in the next fetch packet, while the remainder of the current fetch packet is padded with NOP instructions. In the C64x™ DSP device, the execute boundary restrictions have been removed, thereby, eliminating all of the NOPs added to pad the fetch packet, and thus, decreasing the overall code size. The number of execute packets within a fetch packet can vary from one to eight. Execute packets are dispatched to their respective functional units at the rate of one per clock cycle and the next 256-bit fetch packet is not fetched until all the execute packets from the current fetch packet have been dispatched. After decoding, the instructions simultaneously drive all active functional units for a maximum execution rate of eight instructions every clock cycle. While most results are stored in 32-bit registers, they can be subsequently moved to memory as bytes, half-words, words, or doublewords. All load and store instructions are byte-, half-word-, word-, or doubleword-addressable.

For more details on the C64x CPU functional units enhancements, see the following documents:

The *TMS320C6000 CPU and Instruction Set Reference Guide* (literature number SPRU189)

TMS320C64x Technical Overview (literature number SPRU395)

How To Begin Development Today With the TMS320C6414, TMS320C6415, and TMS320C6416 DSPs application report (literature number SPRA718)

ADVANCE INFORMATION

TMS320C67x is a trademark of Texas Instruments.



CPU (DSP core) description (continued)

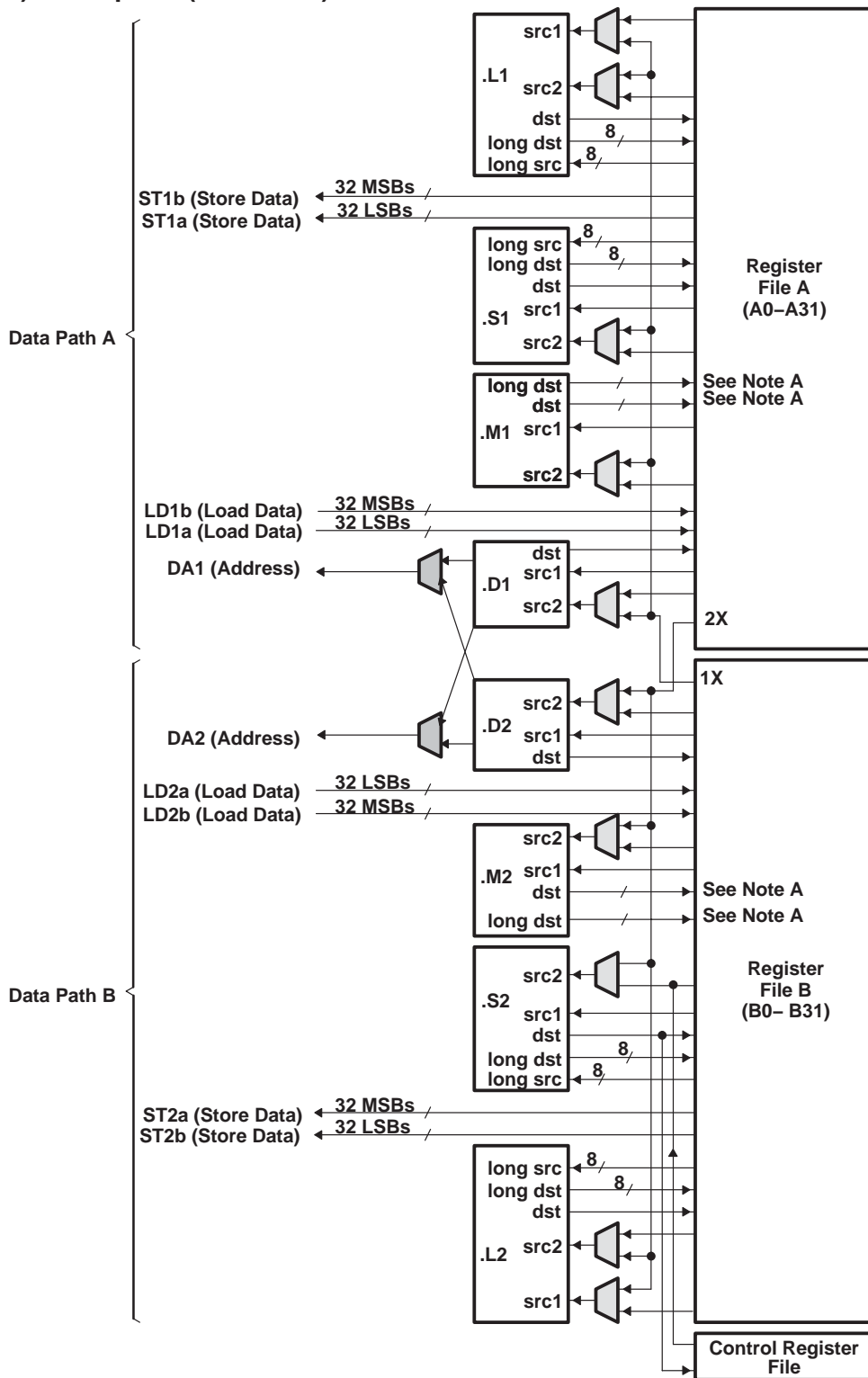

NOTE A: For the .M functional units, the long dst is 32 MSBs and the dst is 32 LSBs.

Figure 1. TMS320C64x™ CPU (DSP Core) Data Paths

ADVANCE INFORMATION

TMS320C6414, TMS320C6415, TMS320C6416 FIXED-POINT DIGITAL SIGNAL PROCESSORS

SPRS146L – FEBRUARY 2001 – REVISED JULY 2004

memory map summary

Table 3 shows the memory map address ranges of the TMS320C64x device. Internal memory is always located at address 0 and can be used as both program and data memory. The external memory address ranges in the C64x device begin at the hex address locations 0x6000 0000 for EMIFB and 0x8000 0000 for EMIFA.

ADVANCE INFORMATION



memory map summary (continued)

Table 3. TMS320C64x Memory Map Summary

| MEMORY BLOCK DESCRIPTION | BLOCK SIZE (BYTES) | HEX ADDRESS RANGE |
|--|--------------------|-----------------------|
| Internal RAM (L2) | 1M | 0000 0000 - 000F FFFF |
| Reserved | 23M | 0010 0000 - 017F FFFF |
| External Memory Interface A (EMIFA) Registers | 256K | 0180 0000 - 0183 FFFF |
| L2 Registers | 256K | 0184 0000 - 0187 FFFF |
| HPI Registers | 256K | 0188 0000 - 018B FFFF |
| McBSP 0 Registers | 256K | 018C 0000 - 018F FFFF |
| McBSP 1 Registers | 256K | 0190 0000 - 0193 FFFF |
| Timer 0 Registers | 256K | 0194 0000 - 0197 FFFF |
| Timer 1 Registers | 256K | 0198 0000 - 019B FFFF |
| Interrupt Selector Registers | 256K | 019C 0000 - 019F FFFF |
| EDMA RAM and EDMA Registers | 256K | 01A0 0000 - 01A3 FFFF |
| McBSP 2 Registers | 256K | 01A4 0000 - 01A7 FFFF |
| EMIFB Registers | 256K | 01A8 0000 - 01AB FFFF |
| Timer 2 Registers | 256K | 01AC 0000 - 01AF FFFF |
| GPIO Registers | 256K | 01B0 0000 - 01B3 FFFF |
| UTOPIA Registers (C6415 and C6416 only) [†] | 256K | 01B4 0000 - 01B7 FFFF |
| TCP/VCP Registers (C6416 only) [‡] | 256K | 01B8 0000 - 01BB FFFF |
| Reserved | 256K | 01BC 0000 - 01BF FFFF |
| PCI Registers (C6415 and C6416 only) [†] | 256K | 01C0 0000 - 01C3 FFFF |
| Reserved | 4M – 256K | 01C4 0000 - 01FF FFFF |
| QDMA Registers | 52 | 0200 0000 - 0200 0033 |
| Reserved | 736M – 52 | 0200 0034 - 2FFF FFFF |
| McBSP 0 Data | 64M | 3000 0000 - 33FF FFFF |
| McBSP 1 Data | 64M | 3400 0000 - 37FF FFFF |
| McBSP 2 Data | 64M | 3800 0000 - 3BFF FFFF |
| UTOPIA Queues (C6415 and C6416 only) [†] | 64M | 3C00 0000 - 3FFF FFFF |
| Reserved | 256M | 4000 0000 - 4FFF FFFF |
| TCP/VCP (C6416 only) [‡] | 256M | 5000 0000 - 5FFF FFFF |
| EMIFB CE0 | 64M | 6000 0000 - 63FF FFFF |
| EMIFB CE1 | 64M | 6400 0000 - 67FF FFFF |
| EMIFB CE2 | 64M | 6800 0000 - 6BFF FFFF |
| EMIFB CE3 | 64M | 6C00 0000 - 6FFF FFFF |
| Reserved | 256M | 7000 0000 - 7FFF FFFF |
| EMIFA CE0 | 256M | 8000 0000 - 8FFF FFFF |
| EMIFA CE1 | 256M | 9000 0000 - 9FFF FFFF |
| EMIFA CE2 | 256M | A000 0000 - AFFF FFFF |
| EMIFA CE3 | 256M | B000 0000 - BFFF FFFF |
| Reserved | 1G | C000 0000 - FFFF FFFF |

[†] For the C6414 device, these memory address locations are reserved. The C6414 device does *not* support the UTOPIA and PCI peripherals.

[‡] Only the C6416 device supports the VCP/TCP Coprocessors. For the C6414 and C6415 devices, these memory address locations are reserved.

TMS320C6414, TMS320C6415, TMS320C6416 FIXED-POINT DIGITAL SIGNAL PROCESSORS

SPRS146L – FEBRUARY 2001 – REVISED JULY 2004

L2 architecture expanded

Figure 2 shows the detail of the L2 architecture on the TMS320C6414, TMS320C6415, and TMS320C6416 devices. For more information on the L2MODE bits, see the cache configuration (CCFG) register bit field descriptions in the *TMS320C64x Two-Level Internal Memory Reference Guide* (literature number SPRU610).

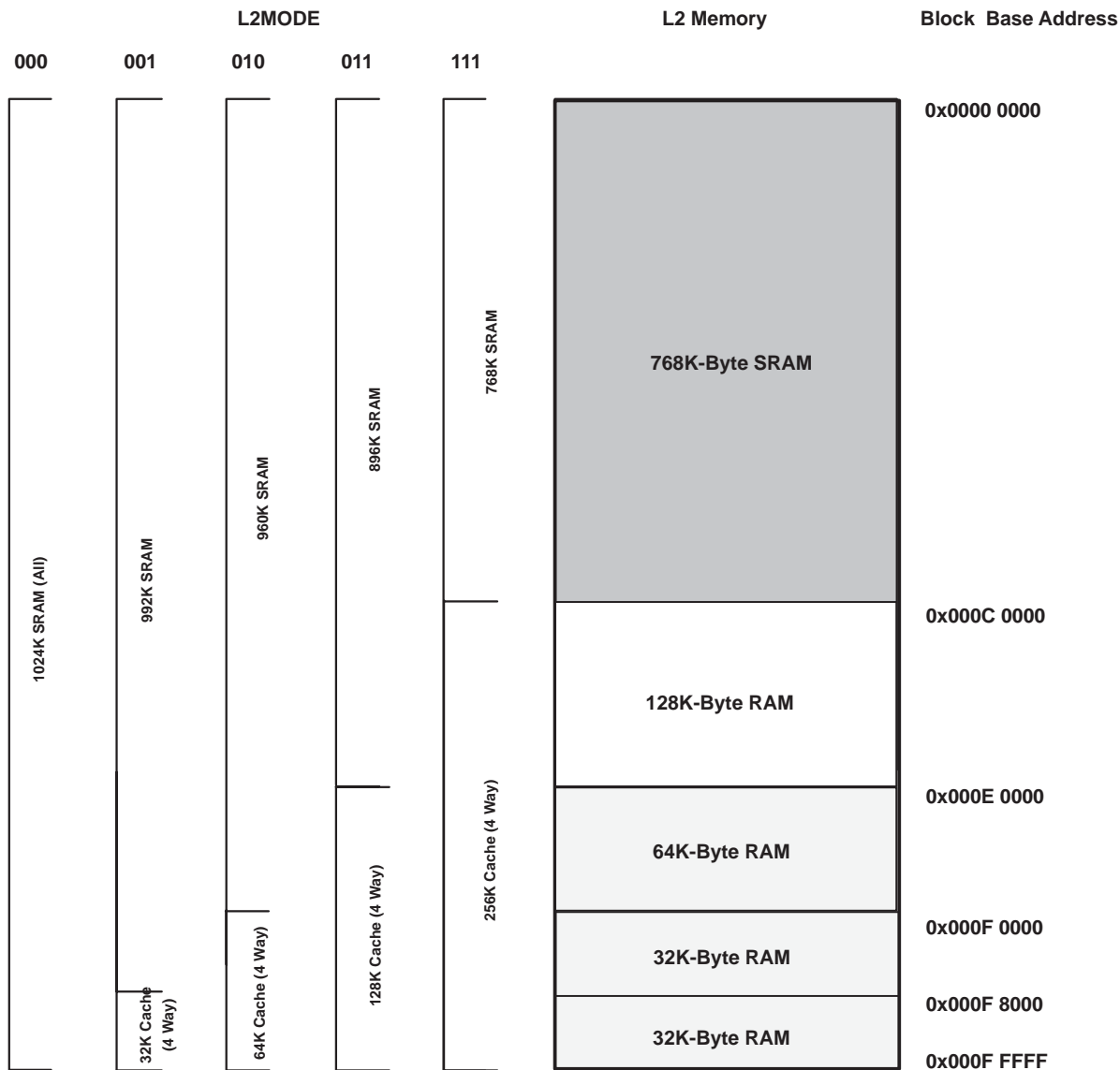

Figure 2. TMS320C6414/C6415/C6416 L2 Architecture Memory Configuration

ADVANCE INFORMATION

peripheral register descriptions

Table 4 through Table 23 identify the peripheral registers for the C6414, C6415, and C6416 devices by their register names, acronyms, and hex address or hex address range. For more detailed information on the register contents, bit names and their descriptions, see the specific peripheral reference guide listed in the *TMS320C6000 DSP Peripherals Overview Reference Guide* (literature number SPRU190).

Table 4. EMIFA Registers

| HEX ADDRESS RANGE | ACRONYM | REGISTER NAME |
|-----------------------|---------|--|
| 0180 0000 | GBLCTL | EMIFA global control |
| 0180 0004 | CECTL1 | EMIFA CE1 space control |
| 0180 0008 | CECTL0 | EMIFA CE0 space control |
| 0180 000C | – | Reserved |
| 0180 0010 | CECTL2 | EMIFA CE2 space control |
| 0180 0014 | CECTL3 | EMIFA CE3 space control |
| 0180 0018 | SDCTL | EMIFA SDRAM control |
| 0180 001C | SDTIM | EMIFA SDRAM refresh control |
| 0180 0020 | SDEXT | EMIFA SDRAM extension |
| 0180 0024 – 0180 003C | – | Reserved |
| 0180 0040 | PDTCTL | Peripheral device transfer (PDT) control |
| 0180 0044 | CESEC1 | EMIFA CE1 space secondary control |
| 0180 0048 | CESEC0 | EMIFA CE0 space secondary control |
| 0180 004C | – | Reserved |
| 0180 0050 | CESEC2 | EMIFA CE2 space secondary control |
| 0180 0054 | CESEC3 | EMIFA CE3 space secondary control |
| 0180 0058 – 0183 FFFF | – | Reserved |

Table 5. EMIFB Registers

| HEX ADDRESS RANGE | ACRONYM | REGISTER NAME |
|-----------------------|---------|--|
| 01A8 0000 | GBLCTL | EMIFB global control |
| 01A8 0004 | CECTL1 | EMIFB CE1 space control |
| 01A8 0008 | CECTL0 | EMIFB CE0 space control |
| 01A8 000C | – | Reserved |
| 01A8 0010 | CECTL2 | EMIFB CE2 space control |
| 01A8 0014 | CECTL3 | EMIFB CE3 space control |
| 01A8 0018 | SDCTL | EMIFB SDRAM control |
| 01A8 001C | SDTIM | EMIFB SDRAM refresh control |
| 01A8 0020 | SDEXT | EMIFB SDRAM extension |
| 01A8 0024 – 01A8 003C | – | Reserved |
| 01A8 0040 | PDTCTL | Peripheral device transfer (PDT) control |
| 01A8 0044 | CESEC1 | EMIFB CE1 space secondary control |
| 01A8 0048 | CESEC0 | EMIFB CE0 space secondary control |
| 01A8 004C | – | Reserved |
| 01A8 0050 | CESEC2 | EMIFB CE2 space secondary control |
| 01A8 0054 | CESEC3 | EMIFB CE3 space secondary control |
| 01A8 0058 – 01AB FFFF | – | Reserved |

TMS320C6414, TMS320C6415, TMS320C6416 FIXED-POINT DIGITAL SIGNAL PROCESSORS

SPRS146L – FEBRUARY 2001 – REVISED JULY 2004

peripheral register descriptions (continued)

Table 6. L2 Cache Registers

| HEX ADDRESS RANGE | ACRONYM | REGISTER NAME | COMMENTS |
|-----------------------|---------------|--|----------|
| 0184 0000 | CCFG | Cache configuration register | |
| 0184 0004 – 0184 0FFC | – | Reserved | |
| 0184 1000 | EDMAWEIGHT | L2 EDMA access control register | |
| 0184 1004 – 0184 1FFC | – | Reserved | |
| 0184 2000 | L2ALLOC0 | L2 allocation register 0 | |
| 0184 2004 | L2ALLOC1 | L2 allocation register 1 | |
| 0184 2008 | L2ALLOC2 | L2 allocation register 2 | |
| 0184 200C | L2ALLOC3 | L2 allocation register 3 | |
| 0184 2010 – 0184 3FFC | – | Reserved | |
| 0184 4000 | L2WBAR | L2 writeback base address register | |
| 0184 4004 | L2WWC | L2 writeback word count register | |
| 0184 4010 | L2WIBAR | L2 writeback invalidate base address register | |
| 0184 4014 | L2WIWC | L2 writeback invalidate word count register | |
| 0184 4018 | L2IBAR | L2 invalidate base address register | |
| 0184 401C | L2IWC | L2 invalidate word count register | |
| 0184 4020 | L1PIBAR | L1P invalidate base address register | |
| 0184 4024 | L1PIWC | L1P invalidate word count register | |
| 0184 4030 | L1DWIBAR | L1D writeback invalidate base address register | |
| 0184 4034 | L1DWIWC | L1D writeback invalidate word count register | |
| 0184 4038 – 0184 4044 | – | Reserved | |
| 0184 4048 | L1DIBAR | L1D invalidate base address register | |
| 0184 404C | L1DIWC | L1D invalidate word count register | |
| 0184 4050 – 0184 4FFC | – | Reserved | |
| 0184 5000 | L2WB | L2 writeback all register | |
| 0184 5004 | L2WBINV | L2 writeback invalidate all register | |
| 0184 5008 – 0184 7FFC | – | Reserved | |
| 0184 8000 – 0184 817C | MAR0 to MAR95 | Reserved | |
| 0184 8180 | MAR96 | Controls EMIFB CE0 range 6000 0000 – 60FF FFFF | |
| 0184 8184 | MAR97 | Controls EMIFB CE0 range 6100 0000 – 61FF FFFF | |
| 0184 8188 | MAR98 | Controls EMIFB CE0 range 6200 0000 – 62FF FFFF | |
| 0184 818C | MAR99 | Controls EMIFB CE0 range 6300 0000 – 63FF FFFF | |
| 0184 8190 | MAR100 | Controls EMIFB CE1 range 6400 0000 – 64FF FFFF | |
| 0184 8194 | MAR101 | Controls EMIFB CE1 range 6500 0000 – 65FF FFFF | |
| 0184 8198 | MAR102 | Controls EMIFB CE1 range 6600 0000 – 66FF FFFF | |
| 0184 819C | MAR103 | Controls EMIFB CE1 range 6700 0000 – 67FF FFFF | |
| 0184 81A0 | MAR104 | Controls EMIFB CE2 range 6800 0000 – 68FF FFFF | |
| 0184 81A4 | MAR105 | Controls EMIFB CE2 range 6900 0000 – 69FF FFFF | |
| 0184 81A8 | MAR106 | Controls EMIFB CE2 range 6A00 0000 – 6AFF FFFF | |
| 0184 81AC | MAR107 | Controls EMIFB CE2 range 6B00 0000 – 6BFF FFFF | |

ADVANCE INFORMATION



peripheral register descriptions (continued)

Table 6. L2 Cache Registers (Continued)

| HEX ADDRESS RANGE | ACRONYM | REGISTER NAME | COMMENTS |
|-----------------------|------------------|--|----------|
| 0184 81B0 | MAR108 | Controls EMIFB CE3 range 6C00 0000 – 6CFF FFFF | |
| 0184 81B4 | MAR109 | Controls EMIFB CE3 range 6D00 0000 – 6DFF FFFF | |
| 0184 81B8 | MAR110 | Controls EMIFB CE3 range 6E00 0000 – 6EFF FFFF | |
| 0184 81BC | MAR111 | Controls EMIFB CE3 range 6F00 0000 – 6FFF FFFF | |
| 0184 81C0 – 0184 81FC | MAR112 to MAR127 | Reserved | |
| 0184 8200 | MAR128 | Controls EMIFA CE0 range 8000 0000 – 80FF FFFF | |
| 0184 8204 | MAR129 | Controls EMIFA CE0 range 8100 0000 – 81FF FFFF | |
| 0184 8208 | MAR130 | Controls EMIFA CE0 range 8200 0000 – 82FF FFFF | |
| 0184 820C | MAR131 | Controls EMIFA CE0 range 8300 0000 – 83FF FFFF | |
| 0184 8210 | MAR132 | Controls EMIFA CE0 range 8400 0000 – 84FF FFFF | |
| 0184 8214 | MAR133 | Controls EMIFA CE0 range 8500 0000 – 85FF FFFF | |
| 0184 8218 | MAR134 | Controls EMIFA CE0 range 8600 0000 – 86FF FFFF | |
| 0184 821C | MAR135 | Controls EMIFA CE0 range 8700 0000 – 87FF FFFF | |
| 0184 8220 | MAR136 | Controls EMIFA CE0 range 8800 0000 – 88FF FFFF | |
| 0184 8224 | MAR137 | Controls EMIFA CE0 range 8900 0000 – 89FF FFFF | |
| 0184 8228 | MAR138 | Controls EMIFA CE0 range 8A00 0000 – 8AFF FFFF | |
| 0184 822C | MAR139 | Controls EMIFA CE0 range 8B00 0000 – 8BFF FFFF | |
| 0184 8230 | MAR140 | Controls EMIFA CE0 range 8C00 0000 – 8CFF FFFF | |
| 0184 8234 | MAR141 | Controls EMIFA CE0 range 8D00 0000 – 8DFF FFFF | |
| 0184 8238 | MAR142 | Controls EMIFA CE0 range 8E00 0000 – 8EFF FFFF | |
| 0184 823C | MAR143 | Controls EMIFA CE0 range 8F00 0000 – 8FFF FFFF | |
| 0184 8240 | MAR144 | Controls EMIFA CE1 range 9000 0000 – 90FF FFFF | |
| 0184 8244 | MAR145 | Controls EMIFA CE1 range 9100 0000 – 91FF FFFF | |
| 0184 8248 | MAR146 | Controls EMIFA CE1 range 9200 0000 – 92FF FFFF | |
| 0184 824C | MAR147 | Controls EMIFA CE1 range 9300 0000 – 93FF FFFF | |
| 0184 8250 | MAR148 | Controls EMIFA CE1 range 9400 0000 – 94FF FFFF | |
| 0184 8254 | MAR149 | Controls EMIFA CE1 range 9500 0000 – 95FF FFFF | |
| 0184 8258 | MAR150 | Controls EMIFA CE1 range 9600 0000 – 96FF FFFF | |
| 0184 825C | MAR151 | Controls EMIFA CE1 range 9700 0000 – 97FF FFFF | |
| 0184 8260 | MAR152 | Controls EMIFA CE1 range 9800 0000 – 98FF FFFF | |
| 0184 8264 | MAR153 | Controls EMIFA CE1 range 9900 0000 – 99FF FFFF | |
| 0184 8268 | MAR154 | Controls EMIFA CE1 range 9A00 0000 – 9AFF FFFF | |
| 0184 826C | MAR155 | Controls EMIFA CE1 range 9B00 0000 – 9BFF FFFF | |
| 0184 8270 | MAR156 | Controls EMIFA CE1 range 9C00 0000 – 9CFF FFFF | |
| 0184 8274 | MAR157 | Controls EMIFA CE1 range 9D00 0000 – 9DFF FFFF | |
| 0184 8278 | MAR158 | Controls EMIFA CE1 range 9E00 0000 – 9EFF FFFF | |
| 0184 827C | MAR159 | Controls EMIFA CE1 range 9F00 0000 – 9FFF FFFF | |
| 0184 8280 | MAR160 | Controls EMIFA CE2 range A000 0000 – A0FF FFFF | |
| 0184 8284 | MAR161 | Controls EMIFA CE2 range A100 0000 – A1FF FFFF | |
| 0184 8288 | MAR162 | Controls EMIFA CE2 range A200 0000 – A2FF FFFF | |
| 0184 828C | MAR163 | Controls EMIFA CE2 range A300 0000 – A3FF FFFF | |
| 0184 8290 | MAR164 | Controls EMIFA CE2 range A400 0000 – A4FF FFFF | |

ADVANCE INFORMATION



TMS320C6414, TMS320C6415, TMS320C6416 FIXED-POINT DIGITAL SIGNAL PROCESSORS

SPRS146L – FEBRUARY 2001 – REVISED JULY 2004

peripheral register descriptions (continued)

Table 6. L2 Cache Registers (Continued)

| HEX ADDRESS RANGE | ACRONYM | REGISTER NAME | COMMENTS |
|-----------------------|------------------|--|----------|
| 0184 8294 | MAR165 | Controls EMIFA CE2 range A500 0000 – A5FF FFFF | |
| 0184 8298 | MAR166 | Controls EMIFA CE2 range A600 0000 – A6FF FFFF | |
| 0184 829C | MAR167 | Controls EMIFA CE2 range A700 0000 – A7FF FFFF | |
| 0184 82A0 | MAR168 | Controls EMIFA CE2 range A800 0000 – A8FF FFFF | |
| 0184 82A4 | MAR169 | Controls EMIFA CE2 range A900 0000 – A9FF FFFF | |
| 0184 82A8 | MAR170 | Controls EMIFA CE2 range AA00 0000 – AAFF FFFF | |
| 0184 82AC | MAR171 | Controls EMIFA CE2 range AB00 0000 – ABFF FFFF | |
| 0184 82B0 | MAR172 | Controls EMIFA CE2 range AC00 0000 – ACFF FFFF | |
| 0184 82B4 | MAR173 | Controls EMIFA CE2 range AD00 0000 – ADFF FFFF | |
| 0184 82B8 | MAR174 | Controls EMIFA CE2 range AE00 0000 – AEFF FFFF | |
| 0184 82BC | MAR175 | Controls EMIFA CE2 range AF00 0000 – AFFF FFFF | |
| 0184 82C0 | MAR176 | Controls EMIFA CE3 range B000 0000 – B0FF FFFF | |
| 0184 82C4 | MAR177 | Controls EMIFA CE3 range B100 0000 – B1FF FFFF | |
| 0184 82C8 | MAR178 | Controls EMIFA CE3 range B200 0000 – B2FF FFFF | |
| 0184 82CC | MAR179 | Controls EMIFA CE3 range B300 0000 – B3FF FFFF | |
| 0184 82D0 | MAR180 | Controls EMIFA CE3 range B400 0000 – B4FF FFFF | |
| 0184 82D4 | MAR181 | Controls EMIFA CE3 range B500 0000 – B5FF FFFF | |
| 0184 82D8 | MAR182 | Controls EMIFA CE3 range B600 0000 – B6FF FFFF | |
| 0184 82DC | MAR183 | Controls EMIFA CE3 range B700 0000 – B7FF FFFF | |
| 0184 82E0 | MAR184 | Controls EMIFA CE3 range B800 0000 – B8FF FFFF | |
| 0184 82E4 | MAR185 | Controls EMIFA CE3 range B900 0000 – B9FF FFFF | |
| 0184 82E8 | MAR186 | Controls EMIFA CE3 range BA00 0000 – BAFF FFFF | |
| 0184 82EC | MAR187 | Controls EMIFA CE3 range BB00 0000 – BBFF FFFF | |
| 0184 82F0 | MAR188 | Controls EMIFA CE3 range BC00 0000 – BCFF FFFF | |
| 0184 82F4 | MAR189 | Controls EMIFA CE3 range BD00 0000 – BDFF FFFF | |
| 0184 82F8 | MAR190 | Controls EMIFA CE3 range BE00 0000 – BEFF FFFF | |
| 0184 82FC | MAR191 | Controls EMIFA CE3 range BF00 0000 – BFFF FFFF | |
| 0184 8300 – 0184 83FC | MAR192 to MAR255 | Reserved | |
| 0184 8400 – 0187 FFFF | – | Reserved | |

ADVANCE INFORMATION



peripheral register descriptions (continued)

Table 7. EDMA Registers

| HEX ADDRESS RANGE | ACRONYM | REGISTER NAME |
|-----------------------|---------|---|
| 01A0 FF9C | EPRH | Event polarity high register |
| 01A0 FFA4 | CIPRH | Channel interrupt pending high register |
| 01A0 FFA8 | CIERH | Channel interrupt enable high register |
| 01A0 FFAC | CCERH | Channel chain enable high register |
| 01A0 FFB0 | ERH | Event high register |
| 01A0 FFB4 | EERH | Event enable high register |
| 01A0 FFB8 | ECRH | Event clear high register |
| 01A0 FFBC | ESRH | Event set high register |
| 01A0 FFC0 | PQAR0 | Priority queue allocation register 0 |
| 01A0 FFC4 | PQAR1 | Priority queue allocation register 1 |
| 01A0 FFC8 | PQAR2 | Priority queue allocation register 2 |
| 01A0 FFCC | PQAR3 | Priority queue allocation register 3 |
| 01A0 FFDC | EPRL | Event polarity low register |
| 01A0 FFE0 | PQSR | Priority queue status register |
| 01A0 FFE4 | CIPRL | Channel interrupt pending low register |
| 01A0 FFE8 | CIERL | Channel interrupt enable low register |
| 01A0 FFEC | CCERL | Channel chain enable low register |
| 01A0 FFF0 | ERL | Event low register |
| 01A0 FFF4 | EERL | Event enable low register |
| 01A0 FFF8 | ECRL | Event clear low register |
| 01A0 FFFC | ESRL | Event set low register |
| 01A1 0000 – 01A3 FFFF | – | Reserved |

ADVANCE INFORMATION

TMS320C6414, TMS320C6415, TMS320C6416 FIXED-POINT DIGITAL SIGNAL PROCESSORS

SPRS146L – FEBRUARY 2001 – REVISED JULY 2004

peripheral register descriptions (continued)

Table 8. EDMA Parameter RAM†

| HEX ADDRESS RANGE | ACRONYM | REGISTER NAME | COMMENTS |
|------------------------|---------|--|----------|
| 01A0 0000 – 01A0 0017 | – | Parameters for Event 0 (6 words) | |
| 01A0 0018 – 01A0 002F | – | Parameters for Event 1 (6 words) | |
| 01A0 0030 – 01A0 0047 | – | Parameters for Event 2 (6 words) | |
| 01A0 0048 – 01A0 005F | – | Parameters for Event 3 (6 words) | |
| 01A0 0060 – 01A0 0077 | – | Parameters for Event 4 (6 words) | |
| 01A0 0078 – 01A0 008F | – | Parameters for Event 5 (6 words) | |
| 01A0 0090 – 01A0 00A7 | – | Parameters for Event 6 (6 words) | |
| 01A0 00A8 – 01A0 00BF | – | Parameters for Event 7 (6 words) | |
| 01A0 00C0 – 01A0 00D7 | – | Parameters for Event 8 (6 words) | |
| 01A0 00D8 – 01A0 00EF | – | Parameters for Event 9 (6 words) | |
| 01A0 00F0 – 01A0 00107 | – | Parameters for Event 10 (6 words) | |
| 01A0 0108 – 01A0 011F | – | Parameters for Event 11 (6 words) | |
| 01A0 0120 – 01A0 0137 | – | Parameters for Event 12 (6 words) | |
| 01A0 0138 – 01A0 014F | – | Parameters for Event 13 (6 words) | |
| 01A0 0150 – 01A0 0167 | – | Parameters for Event 14 (6 words) | |
| 01A0 0168 – 01A0 017F | – | Parameters for Event 15 (6 words) | |
| 01A0 0150 – 01A0 0167 | – | Parameters for Event 16 (6 words) | |
| 01A0 0168 – 01A0 017F | – | Parameters for Event 17 (6 words) | |
| ... | | ... | |
| ... | | ... | |
| 01A0 05D0 – 01A0 05E7 | – | Parameters for Event 62 (6 words) | |
| 01A0 05E8 – 01A0 05FF | – | Parameters for Event 63 (6 words) | |
| 01A0 0600 – 01A0 0617 | – | Reload/link parameters for Event M (6 words) | |
| 01A0 0618 – 01A0 062F | – | Reload/link parameters for Event N (6 words) | |
| ... | | ... | |
| 01A0 07E0 – 01A0 07F7 | – | Reload/link parameters for Event Z (6 words) | |
| 01A0 07F8 – 01A0 07FF | – | Scratch pad area (2 words) | |

† The C6414/C6415/C6416 device has twenty-one parameter sets [six (6) words each] that can be used to reload/link EDMA transfers.

Table 9. Quick DMA (QDMA) and Pseudo Registers

| HEX ADDRESS RANGE | ACRONYM | REGISTER NAME |
|-----------------------|---------|--|
| 0200 0000 | QOPT | QDMA options parameter register |
| 0200 0004 | QSRC | QDMA source address register |
| 0200 0008 | QCNT | QDMA frame count register |
| 0200 000C | QDST | QDMA destination address register |
| 0200 0010 | QIDX | QDMA index register |
| 0200 0014 – 0200 001C | | Reserved |
| 0200 0020 | QSOPT | QDMA pseudo options register |
| 0200 0024 | QSSRC | QDMA pseudo source address register |
| 0200 0028 | QSCNT | QDMA pseudo frame count register |
| 0200 002C | QSDST | QDMA pseudo destination address register |
| 0200 0030 | QSIDX | QDMA pseudo index register |

ADVANCE INFORMATION



peripheral register descriptions (continued)

Table 10. Interrupt Selector Registers

| HEX ADDRESS RANGE | ACRONYM | REGISTER NAME | COMMENTS |
|-----------------------|---------|-----------------------------|---|
| 019C 0000 | MUXH | Interrupt multiplexer high | Selects which interrupts drive CPU interrupts 10–15 (INT10–INT15) |
| 019C 0004 | MUXL | Interrupt multiplexer low | Selects which interrupts drive CPU interrupts 4–9 (INT04–INT09) |
| 019C 0008 | EXTPOL | External interrupt polarity | Sets the polarity of the external interrupts (EXT_INT4–EXT_INT7) |
| 019C 000C – 019C 01FF | – | Reserved | |

Table 11. McBSP 0 Registers

| HEX ADDRESS RANGE | ACRONYM | REGISTER NAME | COMMENTS |
|---------------------------|---------|---|---|
| 018C 0000 | DRR0 | McBSP0 data receive register via Configuration Bus | The CPU and EDMA controller can only read this register; they cannot write to it. |
| 0x3000 0000 – 0x33FF FFFF | DRR0 | McBSP0 data receive register via Peripheral Bus | |
| 018C 0004 | DXR0 | McBSP0 data transmit register via Configuration Bus | |
| 0x3000 0000 – 0x33FF FFFF | DXR0 | McBSP0 data transmit register via Peripheral Bus | |
| 018C 0008 | SPCR0 | McBSP0 serial port control register | |
| 018C 000C | RCR0 | McBSP0 receive control register | |
| 018C 0010 | XCR0 | McBSP0 transmit control register | |
| 018C 0014 | SRGR0 | McBSP0 sample rate generator register | |
| 018C 0018 | MCR0 | McBSP0 multichannel control register | |
| 018C 001C | RCERE00 | McBSP0 enhanced receive channel enable register 0 | |
| 018C 0020 | XCERE00 | McBSP0 enhanced transmit channel enable register 0 | |
| 018C 0024 | PCR0 | McBSP0 pin control register | |
| 018C 0028 | RCERE10 | McBSP0 enhanced receive channel enable register 1 | |
| 018C 002C | XCERE10 | McBSP0 enhanced transmit channel enable register 1 | |
| 018C 0030 | RCERE20 | McBSP0 enhanced receive channel enable register 2 | |
| 018C 0034 | XCERE20 | McBSP0 enhanced transmit channel enable register 2 | |
| 018C 0038 | RCERE30 | McBSP0 enhanced receive channel enable register 3 | |
| 018C 003C | XCERE30 | McBSP0 enhanced transmit channel enable register 3 | |
| 018C 0040 – 018F FFFF | – | Reserved | |

ADVANCE INFORMATION

TMS320C6414, TMS320C6415, TMS320C6416 FIXED-POINT DIGITAL SIGNAL PROCESSORS

SPRS146L – FEBRUARY 2001 – REVISED JULY 2004

peripheral register descriptions (continued)

Table 12. McBSP 1 Registers

| HEX ADDRESS RANGE | ACRONYM | REGISTER NAME | COMMENTS |
|---------------------------|---------|---|---|
| 0190 0000 | DRR1 | McBSP1 data receive register via Configuration Bus | The CPU and EDMA controller can only read this register; they cannot write to it. |
| 0x3400 0000 – 0x37FF FFFF | DRR1 | McBSP1 data receive register via Peripheral Bus | |
| 0190 0004 | DXR1 | McBSP1 data transmit register via Configuration Bus | |
| 0x3400 0000 – 0x37FF FFFF | DXR1 | McBSP1 data transmit register via Peripheral Bus | |
| 0190 0008 | SPCR1 | McBSP1 serial port control register | |
| 0190 000C | RCR1 | McBSP1 receive control register | |
| 0190 0010 | XCR1 | McBSP1 transmit control register | |
| 0190 0014 | SRGR1 | McBSP1 sample rate generator register | |
| 0190 0018 | MCR1 | McBSP1 multichannel control register | |
| 0190 001C | RCERE01 | McBSP1 enhanced receive channel enable register 0 | |
| 0190 0020 | XCERE01 | McBSP1 enhanced transmit channel enable register 0 | |
| 0190 0024 | PCR1 | McBSP1 pin control register | |
| 0190 0028 | RCERE11 | McBSP1 enhanced receive channel enable register 1 | |
| 0190 002C | XCERE11 | McBSP1 enhanced transmit channel enable register 1 | |
| 0190 0030 | RCERE21 | McBSP1 enhanced receive channel enable register 2 | |
| 0190 0034 | XCERE21 | McBSP1 enhanced transmit channel enable register 2 | |
| 0190 0038 | RCERE31 | McBSP1 enhanced receive channel enable register 3 | |
| 0190 003C | XCERE31 | McBSP1 enhanced transmit channel enable register 3 | |
| 0190 0040 – 0193 FFFF | – | Reserved | |

Table 13. McBSP 2 Registers

| HEX ADDRESS RANGE | ACRONYM | REGISTER NAME | COMMENTS |
|---------------------------|---------|---|---|
| 01A4 0000 | DRR2 | McBSP2 data receive register via Configuration Bus | The CPU and EDMA controller can only read this register; they cannot write to it. |
| 0x3800 0000 – 0x3BFF FFFF | DRR2 | McBSP2 data receive register via Peripheral Bus | |
| 01A4 0004 | DXR2 | McBSP2 data transmit register via Configuration Bus | |
| 0x3800 0000 – 0x3BFF FFFF | DXR2 | McBSP2 data transmit register via Peripheral Bus | |
| 01A4 0008 | SPCR2 | McBSP2 serial port control register | |
| 01A4 000C | RCR2 | McBSP2 receive control register | |
| 01A4 0010 | XCR2 | McBSP2 transmit control register | |
| 01A4 0014 | SRGR2 | McBSP2 sample rate generator register | |
| 01A4 0018 | MCR2 | McBSP2 multichannel control register | |
| 01A4 001C | RCERE02 | McBSP2 enhanced receive channel enable register 0 | |
| 01A4 0020 | XCERE02 | McBSP2 enhanced transmit channel enable register 0 | |
| 01A4 0024 | PCR2 | McBSP2 pin control register | |
| 01A4 0028 | RCERE12 | McBSP2 enhanced receive channel enable register 1 | |
| 01A4 002C | XCERE12 | McBSP2 enhanced transmit channel enable register 1 | |
| 01A4 0030 | RCERE22 | McBSP2 enhanced receive channel enable register 2 | |
| 01A4 0034 | XCERE22 | McBSP2 enhanced transmit channel enable register 2 | |
| 01A4 0038 | RCERE32 | McBSP2 enhanced receive channel enable register 3 | |
| 01A4 003C | XCERE32 | McBSP2 enhanced transmit channel enable register 3 | |
| 01A4 0040 – 01A7 FFFF | – | Reserved | |

ADVANCE INFORMATION



peripheral register descriptions (continued)

Table 14. Timer 0 Registers

| HEX ADDRESS RANGE | ACRONYM | REGISTER NAME | COMMENTS |
|-----------------------|---------|--------------------------|---|
| 0194 0000 | CTL0 | Timer 0 control register | Determines the operating mode of the timer, monitors the timer status, and controls the function of the TOUT pin. |
| 0194 0004 | PRD0 | Timer 0 period register | Contains the number of timer input clock cycles to count. This number controls the TSTAT signal frequency. |
| 0194 0008 | CNT0 | Timer 0 counter register | Contains the current value of the incrementing counter. |
| 0194 000C – 0197 FFFF | – | Reserved | |

Table 15. Timer 1 Registers

| HEX ADDRESS RANGE | ACRONYM | REGISTER NAME | COMMENTS |
|-----------------------|---------|--------------------------|---|
| 0198 0000 | CTL1 | Timer 1 control register | Determines the operating mode of the timer, monitors the timer status, and controls the function of the TOUT pin. |
| 0198 0004 | PRD1 | Timer 1 period register | Contains the number of timer input clock cycles to count. This number controls the TSTAT signal frequency. |
| 0198 0008 | CNT1 | Timer 1 counter register | Contains the current value of the incrementing counter. |
| 0198 000C – 019B FFFF | – | Reserved | |

Table 16. Timer 2 Registers

| HEX ADDRESS RANGE | ACRONYM | REGISTER NAME | COMMENTS |
|-----------------------|---------|--------------------------|---|
| 01AC 0000 | CTL2 | Timer 2 control register | Determines the operating mode of the timer, monitors the timer status, and controls the function of the TOUT pin. |
| 01AC 0004 | PRD2 | Timer 2 period register | Contains the number of timer input clock cycles to count. This number controls the TSTAT signal frequency. |
| 01AC 0008 | CNT2 | Timer 2 counter register | Contains the current value of the incrementing counter. |
| 01AC 000C – 01AF FFFF | – | Reserved | |

TMS320C6414, TMS320C6415, TMS320C6416 FIXED-POINT DIGITAL SIGNAL PROCESSORS

SPRS146L – FEBRUARY 2001 – REVISED JULY 2004

peripheral register descriptions (continued)

Table 17. HPI Registers

| HEX ADDRESS RANGE | ACRONYM | REGISTER NAME | COMMENTS |
|-----------------------|------------------|---------------------------------------|--|
| – | HPID | HPI data register | Host read/write access only |
| 0188 0000 | HPIC | HPI control register | HPIC has both Host/CPU read/write access |
| 0188 0004 | HPIA (HPIAW)† | HPI address register (Write) | HPIA has both Host/CPU read/write access |
| 0188 0008 | HPIA (HPIAR)† | HPI address register (Read) | |
| 0188 000C – 0189 FFFF | – | Reserved | |
| 018A 0000 | TRCTL | HPI transfer request control register | |
| 018A 0004 – 018B FFFF | – | Reserved | |

† Host access to the HPIA register updates both the HPIAW and HPIAR registers. The CPU can access HPIAW and HPIAR independently.

Table 18. GPIO Registers

| HEX ADDRESS RANGE | ACRONYM | REGISTER NAME |
|-----------------------|------------|---|
| 01B0 0000 | GPEN | GPIO enable register |
| 01B0 0004 | GPDIR | GPIO direction register |
| 01B0 0008 | GPVAL | GPIO value register |
| 01B0 000C | – | Reserved |
| 01B0 0010 | GPDH | GPIO delta high register |
| 01B0 0014 | GPHM | GPIO high mask register |
| 01B0 0018 | GDDL | GPIO delta low register |
| 01B0 001C | GPLM | GPIO low mask register |
| 01B0 0020 | GPGC | GPIO global control register |
| 01B0 0024 | GPPOL | GPIO interrupt polarity register |
| 01B0 0028 – 01B0 01FF | – | Reserved |
| 01B0 0200 | DEVICE_REV | Silicon Revision Identification Register (For more details, see the device characteristics listed in Table 1.) |
| 01B0 0204 – 01B3 FFFF | – | Reserved |

ADVANCE INFORMATION



peripheral register descriptions (continued)

Table 19. PCI Peripheral Registers (C6415 and C6416 Only)†

| HEX ADDRESS RANGE | ACRONYM | REGISTER NAME |
|-----------------------|---------|---------------------------------------|
| 01C0 0000 | RSTSRC | DSP Reset source/status register |
| 01C0 0004 | – | Reserved |
| 01C0 0008 | PCIIS | PCI interrupt source register |
| 01C0 000C | PCIEN | PCI interrupt enable register |
| 01C0 0010 | DSPMA | DSP master address register |
| 01C0 0014 | PCIMA | PCI master address register |
| 01C0 0018 | PCIMC | PCI master control register |
| 01C0 001C | CDSPA | Current DSP address register |
| 01C0 0020 | CPCIA | Current PCI address register |
| 01C0 0024 | CCNT | Current byte count register |
| 01C0 0028 | – | Reserved |
| 01C0 002C – 01C1 FFEF | – | Reserved |
| 0x01C1 FFF0 | HSR | Host status register |
| 0x01C1 FFF4 | HDCR | Host-to-DSP control register |
| 0x01C1 FFF8 | DSPP | DSP page register |
| 0x01C1 FFFC | – | Reserved |
| 01C2 0000 | EEADD | EEPROM address register |
| 01C2 0004 | EEDAT | EEPROM data register |
| 01C2 0008 | EECTL | EEPROM control register |
| 01C2 000C – 01C2 FFFF | – | Reserved |
| 01C3 0000 | TRCTL | PCI transfer request control register |
| 01C3 0004 – 01C3 FFFF | – | Reserved |

† These PCI registers are *not* supported on the C6414 device.

ADVANCE INFORMATION

TMS320C6414, TMS320C6415, TMS320C6416 FIXED-POINT DIGITAL SIGNAL PROCESSORS

SPRS146L – FEBRUARY 2001 – REVISED JULY 2004

peripheral register descriptions (continued)

Table 20. UTOPIA (C6415 and C6416 Only)†

| HEX ADDRESS RANGE | ACRONYM | REGISTER NAME |
|-----------------------|---------|-----------------------------------|
| 01B4 0000 | UCR | UTOPIA control register |
| 01B4 0004 | – | Reserved |
| 01B4 0008 | – | Reserved |
| 01B4 000C | UIER | UTOPIA interrupt enable register |
| 01B4 0010 | UIPR | UTOPIA interrupt pending register |
| 01B4 0014 | CDR | Clock detect register |
| 01B4 0018 | EIER | Error interrupt enable register |
| 01B4 001C | EIPR | Error interrupt pending register |
| 01B4 0020 – 01B7 FFFF | – | Reserved |

† These UTOPIA registers are *not* supported on the C6414 device.

Table 21. UTOPIA QUEUES (C6415 and C6416 Only)†

| HEX ADDRESS RANGE | ACRONYM | REGISTER NAME |
|-----------------------|---------|-----------------------|
| 3C00 0000 | URQ | UTOPIA receive queue |
| 3D00 0000 | UXQ | UTOPIA transmit queue |
| 3D00 0004 – 3FFF FFFF | – | Reserved |

† These UTOPIA registers are *not* supported on the C6414 device.

ADVANCE INFORMATION



peripheral register descriptions (continued)

Table 22. VCP Registers (C6416 Only)[†]

| EDMA BUS HEX ADDRESS RANGE | PERIPHERAL BUS HEX ADDRESS RANGE | ACRONYM | REGISTER NAME |
|-------------------------------|-------------------------------------|----------|------------------------------------|
| 5000 0000 | 01B8 0000 | VCPIC0 | VCP input configuration register 0 |
| 5000 0004 | 01B8 0004 | VCPIC1 | VCP input configuration register 1 |
| 5000 0008 | 01B8 0008 | VCPIC2 | VCP input configuration register 2 |
| 5000 000C | 01B8 000C | VCPIC3 | VCP input configuration register 3 |
| 5000 0010 | 01B8 0010 | VCPIC4 | VCP input configuration register 4 |
| 5000 0014 | 01B8 0014 | VCPIC5 | VCP input configuration register 5 |
| | | | |
| 5000 0040 | 01B8 0024 | VCPOUT0 | VCP output register 0 |
| 5000 0044 | 01B8 0028 | VCPOUT1 | VCP output register 1 |
| | | | |
| 5000 0080 | – | VCPWBM | VCP branch metrics write register |
| 5000 0088 | – | VCPRDECS | VCP decisions read register |
| – | 01B8 0018 | VCPEXE | VCP execution register |
| – | 01B8 0020 | VCPEND | VCP endian register |
| – | 01B8 0040 | VCPSTAT0 | VCP status register 0 |
| – | 01B8 0044 | VCPSTAT1 | VCP status register 1 |
| – | 01B8 0050 | VCPERR | VCP error register |

[†] These VCP registers are supported on the C6416 device only.

Table 23. TCP Registers (C6416 Only)[‡]

| EDMA BUS HEX ADDRESS RANGE | PERIPHERAL BUS HEX ADDRESS RANGE | ACRONYM | REGISTER NAME |
|-------------------------------|-------------------------------------|----------|-------------------------------------|
| 5800 0000 | 01BA 0000 | TCPIC0 | TCP input configuration register 0 |
| 5800 0004 | 01BA 0004 | TCPIC1 | TCP input configuration register 1 |
| 5800 0008 | 01BA 0008 | TCPIC2 | TCP input configuration register 2 |
| 5800 000C | 01BA 000C | TCPIC3 | TCP input configuration register 3 |
| 5800 0010 | 01BA 0010 | TCPIC4 | TCP input configuration register 4 |
| 5800 0014 | 01BA 0014 | TCPIC5 | TCP input configuration register 5 |
| 5800 0018 | 01BA 0018 | TCPIC6 | TCP input configuration register 6 |
| 5800 001C | 01BA 001C | TCPIC7 | TCP input configuration register 7 |
| 5800 0020 | 01BA 0020 | TCPIC8 | TCP input configuration register 8 |
| 5800 0024 | 01BA 0024 | TCPIC9 | TCP input configuration register 9 |
| 5800 0028 | 01BA 0028 | TCPIC10 | TCP input configuration register 10 |
| 5800 002C | 01BA 002C | TCPIC11 | TCP input configuration register 11 |
| 5800 0030 | 01BA 0030 | TCPOUT | TCP output parameters register |
| 5802 0000 | – | TCPSP | TCP systematics and parities memory |
| 5804 0000 | – | TCPEXT | TCP extrinsics memory |
| 5806 0000 | – | TCPAP | TCP apriori memory |
| 5808 0000 | – | TCPINTER | TCP interleaver memory |
| 580A 0000 | – | TCPHD | TCP hard decisions memory |
| – | 01BA 0038 | TCPEXE | TCP execution register |
| – | 01BA 0040 | TCPEND | TCP endian register |
| – | 01BA 0050 | TCPERR | TCP error register |
| – | 01BA 0058 | TCPSTAT | TCP status register |

[‡] These TCP registers are supported on the C6416 device only.

TMS320C6414, TMS320C6415, TMS320C6416 FIXED-POINT DIGITAL SIGNAL PROCESSORS

SPRS146L – FEBRUARY 2001 – REVISED JULY 2004

EDMA channel synchronization events

The C64x EDMA supports up to 64 EDMA channels which service peripheral devices and external memory. Table 24 lists the source of C64x EDMA synchronization events associated with each of the programmable EDMA channels. For the C64x device, the association of an event to a channel is fixed; each of the EDMA channels has one specific event associated with it. These specific events are captured in the EDMA event registers (ERL, ERH) even if the events are disabled by the EDMA event enable registers (EERL, EERH). The priority of each event can be specified independently in the transfer parameters stored in the EDMA parameter RAM. For more detailed information on the EDMA module and how EDMA events are enabled, captured, processed, linked, chained, and cleared, etc., see the *TMS320C6000 DSP Enhanced Direct Memory Access (EDMA) Controller Reference Guide* (literature number SPRU234).

ADVANCE INFORMATION



EDMA channel synchronization events (continued)

Table 24. TMS320C64x EDMA Channel Synchronization Events†

| EDMA CHANNEL | EVENT NAME | EVENT DESCRIPTION |
|--------------|-----------------|--|
| 0 | DSP_INT | HPI/PCI-to-DSP interrupt (PCI peripheral supported on C6415 and C6416 only)‡ |
| 1 | TINT0 | Timer 0 interrupt |
| 2 | TINT1 | Timer 1 interrupt |
| 3 | SD_INTA | EMIFA SDRAM timer interrupt |
| 4 | GPINT4/EXT_INT4 | GPIO event 4/External interrupt pin 4 |
| 5 | GPINT5/EXT_INT5 | GPIO event 5/External interrupt pin 5 |
| 6 | GPINT6/EXT_INT6 | GPIO event 6/External interrupt pin 6 |
| 7 | GPINT7/EXT_INT7 | GPIO event 7/External interrupt pin 7 |
| 8 | GPINT0 | GPIO event 0 |
| 9 | GPINT1 | GPIO event 1 |
| 10 | GPINT2 | GPIO event 2 |
| 11 | GPINT3 | GPIO event 3 |
| 12 | XEVT0 | McBSP0 transmit event |
| 13 | REVT0 | McBSP0 receive event |
| 14 | XEVT1 | McBSP1 transmit event |
| 15 | REVT1 | McBSP1 receive event |
| 16 | – | None |
| 17 | XEVT2 | McBSP2 transmit event |
| 18 | REVT2 | McBSP2 receive event |
| 19 | TINT2 | Timer 2 interrupt |
| 20 | SD_INTB | EMIFB SDRAM timer interrupt |
| 21 | – | Reserved, for future expansion |
| 22–27 | – | None |
| 28 | VCPREVT | VCP receive event (C6416 only)§ |
| 29 | VCPX EVT | VCP transmit event (C6416 only)§ |
| 30 | TCPREVT | TCP receive event (C6416 only)§ |
| 31 | TCPX EVT | TCP transmit event (C6416 only)§ |
| 32 | UREVT | UTOPIA receive event (C6415 and C6416 only)‡ |
| 33–39 | – | None |
| 40 | UXEVT | UTOPIA transmit event (C6415 and C6416 only)‡ |
| 41–47 | – | None |
| 48 | GPINT8 | GPIO event 8 |
| 49 | GPINT9 | GPIO event 9 |
| 50 | GPINT10 | GPIO event 10 |
| 51 | GPINT11 | GPIO event 11 |
| 52 | GPINT12 | GPIO event 12 |
| 53 | GPINT13 | GPIO event 13 |
| 54 | GPINT14 | GPIO event 14 |
| 55 | GPINT15 | GPIO event 15 |
| 56–63 | – | None |

† In addition to the events shown in this table, each of the 64 channels can also be synchronized with the transfer completion or alternate transfer completion events. For more detailed information on EDMA event-transfer chaining, see the *TMS320C6000 DSP Enhanced Direct Memory Access (EDMA) Controller Reference Guide* (literature number SPRU234).

‡ The PCI and UTOPIA peripherals are not supported on the C6414 device; therefore, these EDMA synchronization events are reserved.

§ The VCP/TCP EDMA synchronization events are supported on the C6416 only. For the C6414 and C6415 devices, these events are reserved.

TMS320C6414, TMS320C6415, TMS320C6416 FIXED-POINT DIGITAL SIGNAL PROCESSORS

SPRS146L – FEBRUARY 2001 – REVISED JULY 2004

interrupt sources and interrupt selector

The C64x DSP core supports 16 prioritized interrupts, which are listed in Table 25. The highest-priority interrupt is INT_00 (dedicated to RESET) while the lowest-priority interrupt is INT_15. The first four interrupts (INT_00–INT_03) are non-maskable and fixed. The remaining interrupts (INT_04–INT_15) are maskable and default to the interrupt source specified in Table 25. The interrupt source for interrupts 4–15 can be programmed by modifying the selector value (binary value) in the corresponding fields of the Interrupt Selector Control registers: MUXH (address 0x019C0000) and MUXL (address 0x019C0004).

interrupt sources and interrupt selector (continued)

Table 25. C64x DSP Interrupts

| CPU INTERRUPT NUMBER | INTERRUPT SELECTOR CONTROL REGISTER | SELECTOR VALUE (BINARY) | INTERRUPT EVENT | INTERRUPT SOURCE |
|----------------------|-------------------------------------|-------------------------|-----------------|--|
| INT_00† | – | – | RESET | |
| INT_01† | – | – | NMI | |
| INT_02† | – | – | Reserved | Reserved. Do not use. |
| INT_03† | – | – | Reserved | Reserved. Do not use. |
| INT_04‡ | MUXL[4:0] | 00100 | GPINT4/EXT_INT4 | GPIO interrupt 4/External interrupt pin 4 |
| INT_05‡ | MUXL[9:5] | 00101 | GPINT5/EXT_INT5 | GPIO interrupt 5/External interrupt pin 5 |
| INT_06‡ | MUXL[14:10] | 00110 | GPINT6/EXT_INT6 | GPIO interrupt 6/External interrupt pin 6 |
| INT_07‡ | MUXL[20:16] | 00111 | GPINT7/EXT_INT7 | GPIO interrupt 7/External interrupt pin 7 |
| INT_08‡ | MUXL[25:21] | 01000 | EDMA_INT | EDMA channel (0 through 63) interrupt |
| INT_09‡ | MUXL[30:26] | 01001 | EMU_DTDMA | EMU DTDMA |
| INT_10‡ | MUXH[4:0] | 00011 | SD_INTA | EMIFA SDRAM timer interrupt |
| INT_11‡ | MUXH[9:5] | 01010 | EMU_RTDXRX | EMU real-time data exchange (RTDX) receive |
| INT_12‡ | MUXH[14:10] | 01011 | EMU_RTDXTX | EMU RTDX transmit |
| INT_13‡ | MUXH[20:16] | 00000 | DSP_INT | HPI/PCI-to-DSP interrupt (PCI supported on C6415 and C6416 only) |
| INT_14‡ | MUXH[25:21] | 00001 | TINT0 | Timer 0 interrupt |
| INT_15‡ | MUXH[30:26] | 00010 | TINT1 | Timer 1 interrupt |
| – | – | 01100 | XINT0 | McBSP0 transmit interrupt |
| – | – | 01101 | RINT0 | McBSP0 receive interrupt |
| – | – | 01110 | XINT1 | McBSP1 transmit interrupt |
| – | – | 01111 | RINT1 | McBSP1 receive interrupt |
| – | – | 10000 | GPINT0 | GPIO interrupt 0 |
| – | – | 10001 | XINT2 | McBSP2 transmit interrupt |
| – | – | 10010 | RINT2 | McBSP2 receive interrupt |
| – | – | 10011 | TINT2 | Timer 2 interrupt |
| – | – | 10100 | SD_INTB | EMIFB SDRAM timer interrupt |
| – | – | 10101 | Reserved | Reserved. Do not use. |
| – | – | 10110 | Reserved | Reserved. Do not use. |
| – | – | 10111 | UINT | UTOPIA interrupt (C6415/C6416 only) |
| – | – | 11000 – 11101 | Reserved | Reserved. Do not use. |
| – | – | 11110 | VCPINT | VCP interrupt (C6416 only) |
| – | – | 11111 | TCPINT | TCP interrupt (C6416 only) |

† Interrupts INT_00 through INT_03 are non-maskable and fixed.

‡ Interrupts INT_04 through INT_15 are programmable by modifying the binary selector values in the Interrupt Selector Control registers fields. Table 25 shows the default interrupt sources for Interrupts INT_04 through INT_15. For more detailed information on interrupt sources and selection, see the *TMS320C6000 DSP Interrupt Selector Reference Guide* (literature number SPRU646).

TMS320C6414, TMS320C6415, TMS320C6416 FIXED-POINT DIGITAL SIGNAL PROCESSORS

SPRS146L – FEBRUARY 2001 – REVISED JULY 2004

signal groups description

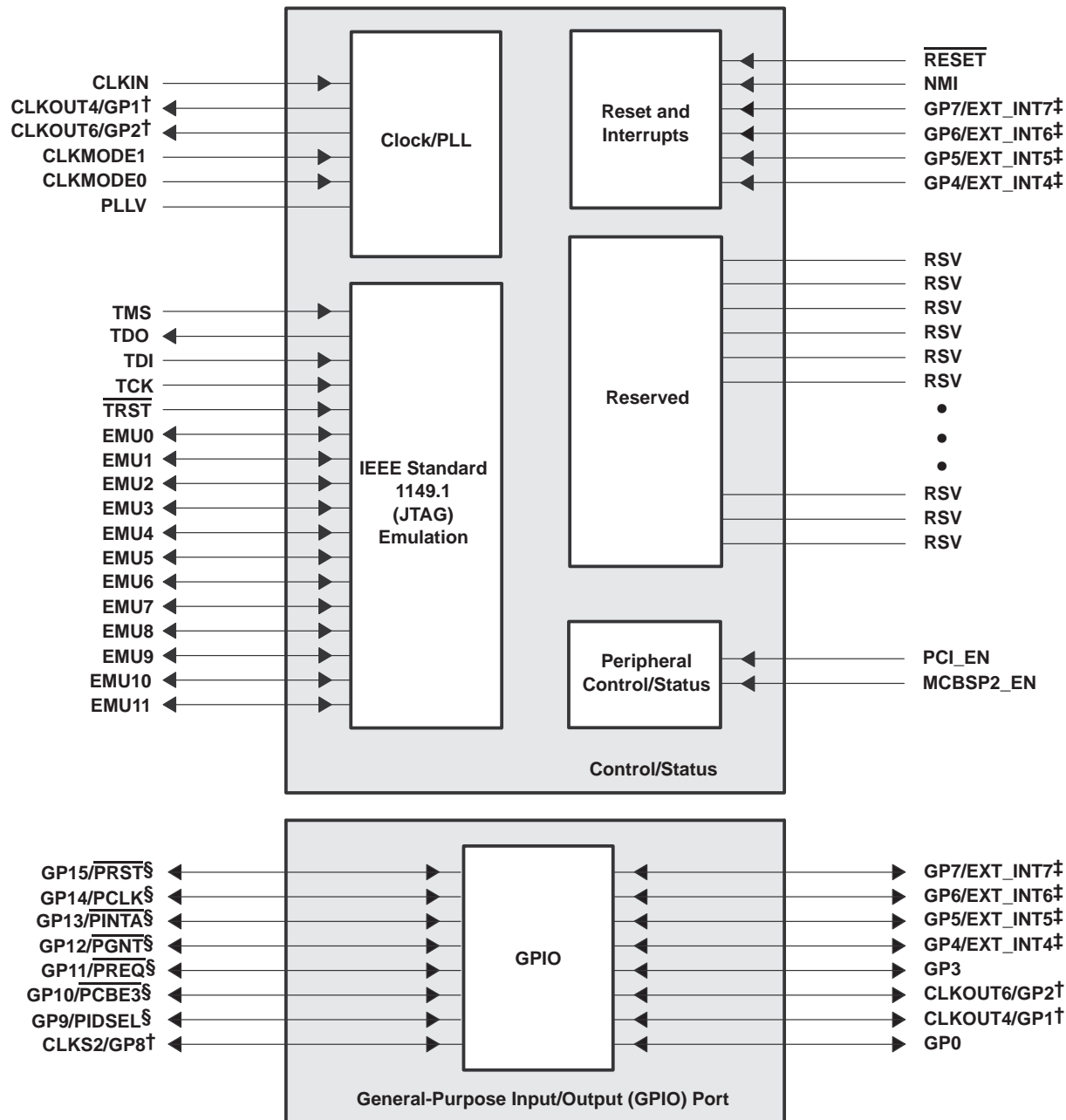

† These pins are muxed with the GPIO port pins and by default these signals function as clocks (CLKOUT4 or CLKOUT6) or McBSP2 clock source (CLKS2). To use these muxed pins as GPIO signals, the appropriate GPIO register bits (GPxEN and GPxDIR) must be properly enabled and configured. For more details, see the Device Configurations section of this data sheet.

‡ These pins are GPIO pins that can also function as external interrupt sources (EXT_INT[7:4]). Default after reset is EXT_INTx or GPIO as input-only.

§ For the C6415 and C6416 devices, these GPIO pins are muxed with the PCI peripheral pins. By default, these signals are set up to no function with both the GPIO and PCI pin functions *disabled*. For more details on these muxed pins, see the Device Configurations section of this data sheet. For the C6414 device, the GPIO peripheral pins are *not* muxed; the C6414 device does *not* support the PCI peripheral.

Figure 3. CPU and Peripheral Signals

ADVANCE INFORMATION

signal groups description (continued)

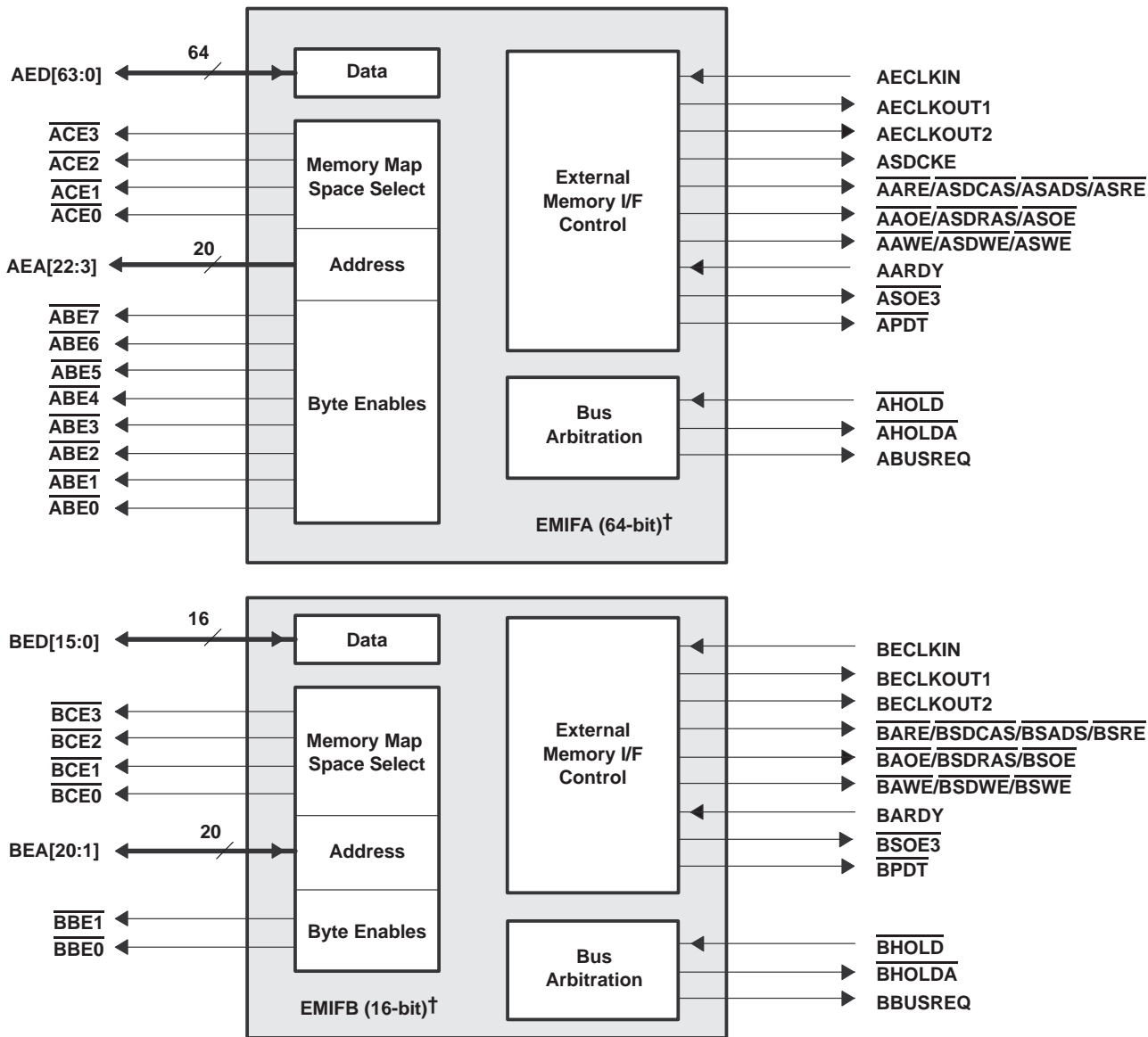

† These C64x™ devices have two EMIFs (64-bit EMIFA and 16-bit EMIFB). The prefix "A" in front of a signal name indicates it is an EMIFA signal whereas a prefix "B" in front of a signal name indicates it is an EMIFB signal. Throughout the rest of this document, in generic EMIF areas of discussion, the prefix "A" or "B" may be omitted from the signal name.

Figure 4. Peripheral Signals

ADVANCE INFORMATION

TMS320C6414, TMS320C6415, TMS320C6416 FIXED-POINT DIGITAL SIGNAL PROCESSORS

SPRS146L – FEBRUARY 2001 – REVISED JULY 2004

signal groups description (continued)

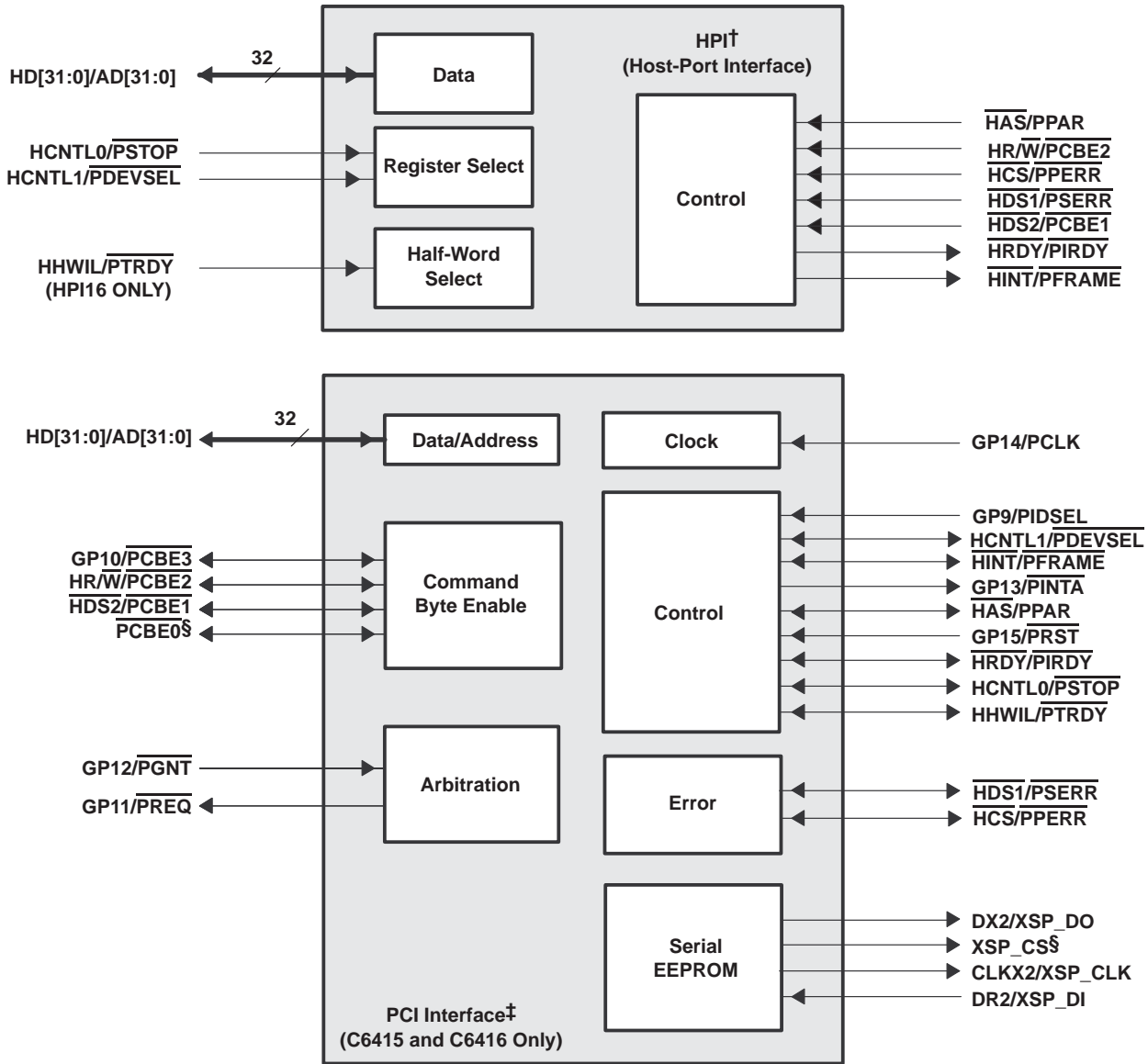

† For the C6415 and C6416 devices, these HPI pins are muxed with the PCI peripheral. By default, these signals function as HPI. For more details on these muxed pins, see the Device Configurations section of this data sheet. For the C6414 device, these HPI pins are *not* muxed; the C6414 device does *not* support the PCI peripheral.

‡ For the C6415 and C6416 devices, these PCI pins (excluding PCBE0 and XSP_CS) are muxed with the HPI, McBSP2, or GPIO peripherals. By default, these signals function as HPI, McBSP2, and no function, respectively. For more details on these muxed pins, see the Device Configurations section of this data sheet. For the C6414 device, the HPI, McBSP2, and GPIO peripheral pins are *not* muxed; the C6414 device does *not* support the PCI peripheral.

§ For the C6414 device, these pins are “Reserved (leave unconnected, **do not** connect to power or ground).”

Figure 4. Peripheral Signals (Continued)

ADVANCE INFORMATION

signal groups description (continued)

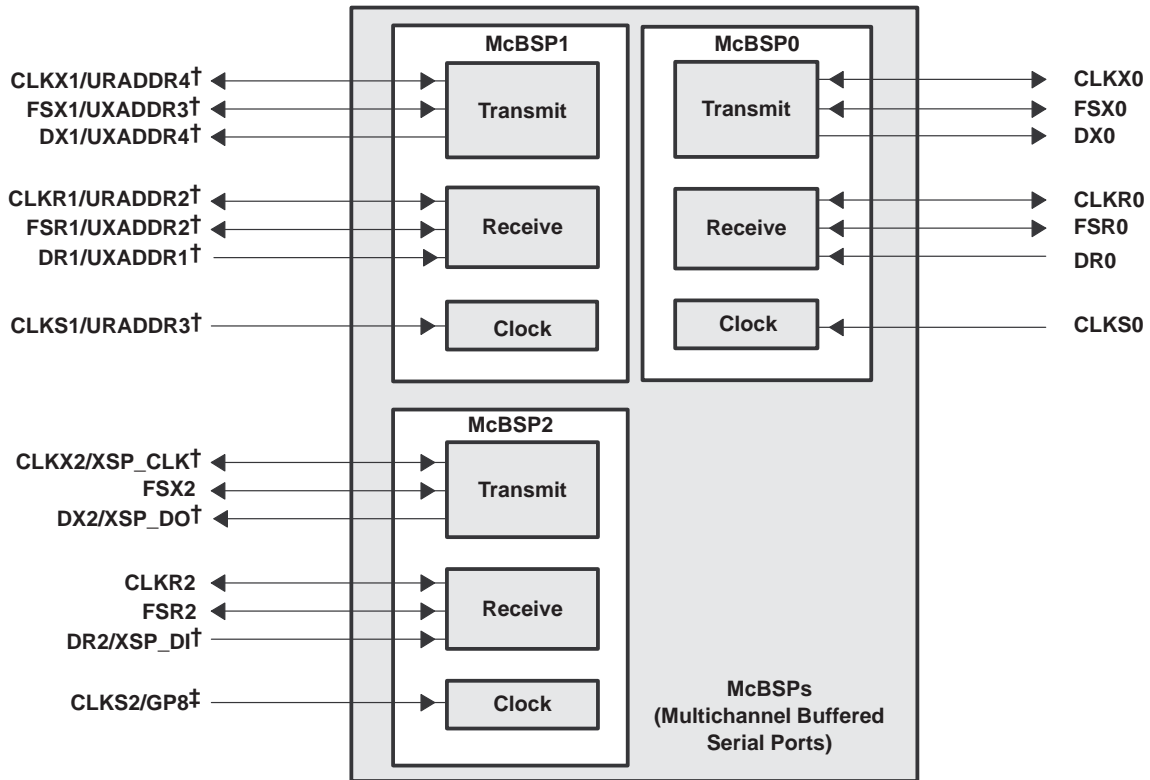

† For the C6415 and C6416 devices, these McBSP2 and McBSP1 pins are muxed with the PCI and UTOPIA peripherals, respectively. By default, these signals function as McBSP2 and McBSP1, respectively. For more details on these muxed pins, see the Device Configurations section of this data sheet.

For the C6414 device, these McBSP2 and McBSP1 peripheral pins are *not* muxed; the C6414 device does *not* support PCI and UTOPIA peripherals.

‡ The McBSP2 clock source pin (CLKS2, default) is muxed with the GP8 pin. To use this muxed pin as the GP8 signal, the appropriate GPIO register bits (GP8EN and GP8DIR) must be properly enabled and configured. For more details, see the Device Configurations section of this data sheet.

Figure 4. Peripheral Signals (Continued)

ADVANCE INFORMATION

signal groups description (continued)

ADVANCE INFORMATION

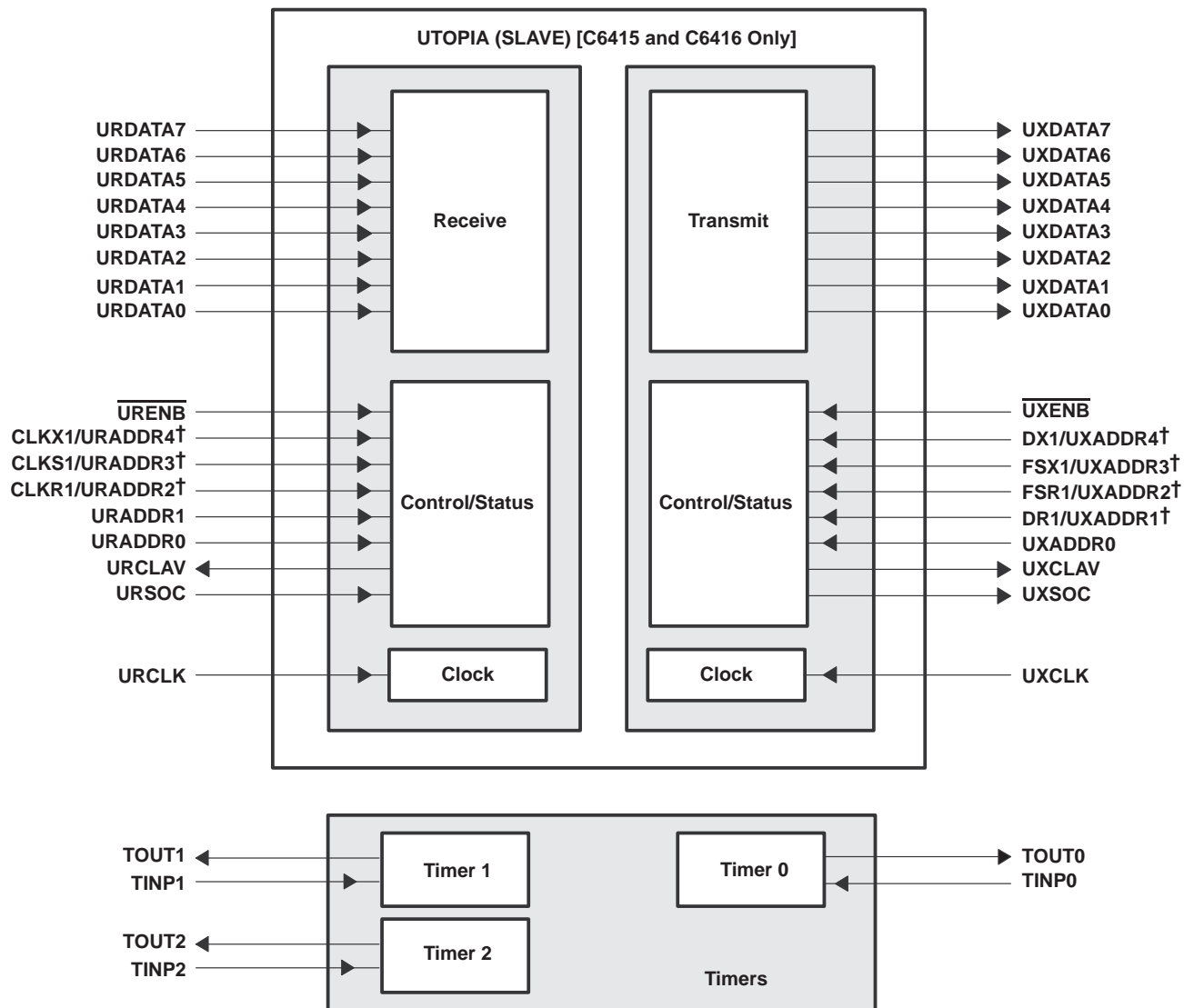

\dagger For the C6415 and C6416 devices, these UTOPIA pins are muxed with the McBSP1 peripheral. By default, these signals function as McBSP1. For more details on these muxed pins, see the Device Configurations section of this data sheet.
 For the C6414 device, these McBSP1 peripheral pins are *not* muxed; the C6414 does *not* support the UTOPIA peripheral.

Figure 4. Peripheral Signals (Continued)

DEVICE CONFIGURATIONS

The C6414, C6415, and C6416 peripheral selections and other device configurations are determined by external pullup/pulldown resistors on the following pins (all of which are latched during device reset):

- peripherals selection (C6415 and C6416 devices)
 - BEA11 (UTOPIA_EN)
 - PCI_EN (for C6415 or C6416, see Table 27 footnotes)
 - MCBSP2_EN (for C6415 or C6416, see Table 27 footnotes)

The C6414 device does *not* support the PCI and UTOPIA peripherals; for proper operation of the C6414 device, do *not* oppose the internal *pulldowns* (IPDs) on the BEA11, PCI_EN, and MCBSP2_EN pins. (For IPU/IPDs on pins, see the Terminal Functions table of this data sheet.)

- other device configurations (C64x)
 - BEA[20:13, 7]
 - HD5

peripherals selection

Some C6415/C6416 peripherals share the same pins (internally muxed) and are mutually exclusive (i.e., HPI, general-purpose input/output pins GP[15:9], PCI and its internal EEPROM, McBSP1, McBSP2, and UTOPIA). The VCP/TCP coprocessors (C6416 only) and other C64x peripherals (i.e., the Timers, McBSP0, and the GP[8:0] pins), are always available.

- UTOPIA and McBSP1 peripherals

The UTOPIA_EN pin (BEA11) is latched at reset. For C6415 and C6416 devices, this pin selects whether the UTOPIA peripheral or McBSP1 peripheral is functionally enabled (see Table 26).

The C6414 device does *not* support the UTOPIA peripheral; for proper device operation, do *not* oppose the internal *pulldown* (IPD) on the BEA11 pin.

Table 26. UTOPIA_EN Peripheral Selection (McBSP1 and UTOPIA) (C6415/C6416 Only)

| PERIPHERAL SELECTION UTOPIA_EN (BEA11) Pin [D16] | PERIPHERALS SELECTED | | DESCRIPTION |
|--|----------------------|--------|---|
| | UTOPIA | McBSP1 | |
| 0 | | √ | McBSP1 is enabled and UTOPIA is disabled [default]. This means all multiplexed McBSP1/UTOPIA pins function as McBSP1 and all other standalone UTOPIA pins are tied-off (Hi-Z). |
| 1 | √ | | UTOPIA is enabled and McBSP1 is disabled. This means all multiplexed McBSP1/UTOPIA pins now function as UTOPIA and all other standalone McBSP1 pins are tied-off (Hi-Z). |

- HPI, GP[15:9], PCI, EEPROM (internal to PCI), and McBSP2 peripherals

The PCI_EN and MCBSP2_EN pins are latched at reset. They determine specific peripheral selection for the C6415 and C6416 devices, summarized in Table 27.

The C6414 device does *not* support the PCI peripheral; for proper device operation, do *not* oppose the internal pulldowns (IPDs) on the PCI_EN and MCBSP2_EN pins.

DEVICE CONFIGURATIONS (CONTINUED)

Table 27. PCI_EN and MCBSP2_EN Peripheral Selection (HPI, GP[15:9], PCI, and McBSP2)

| PERIPHERAL SELECTION† | | PERIPHERALS SELECTED | | | | |
|-----------------------|------------------------|----------------------|----------|-----|-----------------------------|--------|
| PCI_EN Pin [AA4] | MCBSP2_EN Pin [AF3] | HPI | GP[15:9] | PCI | EEPROM (Internal to PCI) | McBSP2 |
| 0 | 0 | √ | √ | | | √ |
| 0 | 1 | √ | √ | | | √ |
| 1 | 0 | | | √ | √ | ‡ |
| 1 | 1 | | | √ | | √ |

† The PCI_EN pin *must* be driven valid at all times and the user *must not* switch values throughout device operation.

The MCBSP2_EN pin *must* be driven valid at all times and the user *can* switch values throughout device operation.

‡ The only time McBSP2 is disabled is when both PCI_EN = 1 and MCBSP2_EN = 0. This configuration enables, at reset, the auto-initialization of the PCI peripheral through the PCI internal EEPROM [provided the PCI EEPROM Auto-Initialization pin (BEA13) is pulled up (EEAI = 1)]. The user can then enable the McBSP2 peripheral (disabling EEPROM) by dynamically changing MCBSP2_EN to a “1” after the device is initialized (out of reset).

- If the PCI is disabled (PCI_EN = 0), the HPI peripheral is enabled and GP[15:9] pins can be programmed as GPIO, provided the GPxEN and GPxDIR bits are properly configured.

This means all multiplexed HPI/PCI pins function as HPI and all standalone PCI pins ($\overline{PCBE0}$ and XSP_CS) are tied-off (Hi-Z). Also, the multiplexed GPIO/PCI pins can be used as GPIO with the proper software configuration of the GPIO enable and direction registers (for more details, see Table 29).

- If the PCI is enabled (PCI_EN = 1), the HPI peripheral is disabled.

This means all multiplexed HPI/PCI pins function as PCI. Also, the multiplexed GPIO/PCI pins function as PCI pins (for more details, see Table 29).

- The MCBSP2_EN pin, in combination with the PCI_EN pin, controls the selection of the McBSP2 peripheral and the PCI internal EEPROM (for more details, see Table 27 and its footnotes).

other device configurations

Table 28 describes the C6414, C6415, and C6416 devices configuration pins, which are set up via external pullup/pulldown resistors through the specified EMIFB address bus pins (BEA[20:13, 11, 9:7]) and the HD5 pin. For more details on these device configuration pins, see the Terminal Functions table and the Debugging Considerations section.



DEVICE CONFIGURATIONS (CONTINUED)

Table 28. Device Configuration Pins (BEA[20:13, 9:7], HD5, and BEA11)

| CONFIGURATION PIN | NO. | FUNCTIONAL DESCRIPTION |
|-------------------|------------|--|
| BEA20 | E16 | Device Endian mode (LEND) 0 – System operates in Big Endian mode 1 – System operates in Little Endian mode (default) |
| BEA[19:18] | [D18, C18] | Bootmode [1:0] 00 – No boot 01 – HPI boot 10 – EMIFB 8-bit ROM boot with default timings (default mode) 11 – Reserved |
| BEA[17:16] | [B18, A18] | EMIFA input clock select Clock mode select for EMIFA (AECLKIN_SEL[1:0]) 00 – AECLKIN (default mode) 01 – CPU/4 Clock Rate 10 – CPU/6 Clock Rate 11 – Reserved |
| BEA[15:14] | [D17, C17] | EMIFB input clock select Clock mode select for EMIFB (BECLKIN_SEL[1:0]) 00 – BECLKIN (default mode) 01 – CPU/4 Clock Rate 10 – CPU/6 Clock Rate 11 – Reserved |
| BEA13 | B17 | PCI EEPROM Auto-Initialization (EEAI) [C6415 and C6416 devices only] [The C6414 device does <i>not</i> support the PCI peripheral; for proper device operation, do not oppose the internal pulldown (IPD) on the BEA13 pin.] PCI auto-initialization via external EEPROM 0 – PCI auto-initialization through EEPROM is disabled; the PCI peripheral uses the specified PCI default values (default). 1 – PCI auto-initialization through EEPROM is enabled; the PCI peripheral is configured through EEPROM provided the PCI peripheral pin is enabled (PCI_EN = 1) and the McBSP2 peripheral pin is disabled (MCBSP2_EN = 0). Note: If the PCI peripheral is disabled (PCI_EN pin = 0), this pin must not be pulled up. For more information on the PCI EEPROM default values, see the <i>TMS320C6000 DSP Peripheral Component Interconnect (PCI) Reference Guide</i> (literature number SPRU581). |
| BEA11 | D16 | UTOPIA Enable (UTOPIA_EN) [C6415 and C6416 devices only] [The C6414 device does <i>not</i> support the UTOPIA peripheral; for proper device operation, do not oppose the internal pulldown (IPD) on the BEA11 pin.] UTOPIA peripheral enable (functional) 0 – UTOPIA peripheral disabled (McBSP1 functions are enabled). [default] This means all multiplexed McBSP1/UTOPIA pins function as McBSP1 and all other standalone UTOPIA pins are tied-off (Hi-Z). 1 – UTOPIA peripheral enabled (McBSP1 functions are disabled). This means all multiplexed McBSP1/UTOPIA pins now function as UTOPIA and all other standalone McBSP1 pins are tied-off (Hi-Z). |

ADVANCE INFORMATION

TMS320C6414, TMS320C6415, TMS320C6416 FIXED-POINT DIGITAL SIGNAL PROCESSORS

SPRS146L – FEBRUARY 2001 – REVISED JULY 2004

DEVICE CONFIGURATIONS (CONTINUED)

Table 28. Device Configuration Pins (BEA[20:13, 9:7], HD5, and BEA11) (Continued)

| CONFIGURATION PIN | NO. | FUNCTIONAL DESCRIPTION | | |
|---|-------------------|--|---|--|
| | | C6414 Devices | C6415 Devices | C6416 Devices |
| BEA7 BEA8 BEA9 | D15 A16 B16 | Do not oppose internal pulldown (IPD) Do not oppose IPD Do not oppose IPD | Pullup† Do not oppose IPD Do not oppose IPD | Do not oppose IPD Pullup† Pullup† |
| †For proper device operation, this pin must be externally pulled up with a 1-kΩ resistor. | | | | |
| HD5 | Y1 | HPI peripheral bus width (HPI_WIDTH) 0 – HPI operates as an HPI16. (HPI bus is 16 bits wide. HD[15:0] pins are used and the remaining HD[31:16] pins are reserved pins in the Hi-Z state.) 1 – HPI operates as an HPI32. (HPI bus is 32 bits wide. All HD[31:0] pins are used for host-port operations.) | | |

ADVANCE INFORMATION



DEVICE CONFIGURATIONS (CONTINUED)

multiplexed pins

Multiplexed pins are pins that are shared by more than one peripheral and are internally multiplexed. Some of these pins are configured by software, and the others are configured by external pullup/pulldown resistors only at reset. Those muxed pins that are configured by software can be programmed to switch functionalities at any time. Those muxed pins that are configured by external pullup/pulldown resistors are mutually exclusive; only one peripheral has primary control of the function of these pins after reset. Table 29 identifies the multiplexed pins on the C6414, C6415, and C6416 devices; shows the default (primary) function and the default settings after reset; and describes the pins, registers, etc. necessary to configure specific multiplexed functions.

debugging considerations

It is recommended that external connections be provided to device configuration pins, including CLKMODE[1:0], BEA[20:13, 11, 9:7], HD5/AD5, PCI_EN, and MCBSP2_EN. Although internal pullup/pulldown resistors exist on these pins (except for HD5/AD5), providing external connectivity adds convenience to the user in debugging and flexibility in switching operating modes.

Internal pullup/pulldown resistors also exist on the non-configuration pins on the BEA bus (BEA[12, 10, 6:1]). Do not oppose the internal pullup/pulldown resistors on these non-configuration pins with external pullup/pulldown resistors. If an external controller provides signals to these non-configuration pins, these signals must be driven to the default state of the pins at reset, or not be driven at all.

For the internal pullup/pulldown resistors on the C6414, C6415, and C6416 device pins, see the terminal functions table.

TMS320C6414, TMS320C6415, TMS320C6416 FIXED-POINT DIGITAL SIGNAL PROCESSORS

SPRS146L – FEBRUARY 2001 – REVISED JULY 2004

DEVICE CONFIGURATIONS (CONTINUED)

Table 29. C6414, C6415, and C6416 Device Multiplexed Pins†

| MULTIPLEXED PINS | | DEFAULT FUNCTION | DEFAULT SETTING | DESCRIPTION |
|----------------------------------|------|---------------------------|--|--|
| NAME | NO. | | | |
| CLKOUT4/GP1‡ | AE6 | CLKOUT4 | GP1EN = 0 (disabled) | These pins are software-configurable. To use these pins as GPIO pins, the GPxEN bits in the GPIO Enable Register and the GPxDIR bits in the GPIO Direction Register must be properly configured. GPxEN = 1: GPx pin enabled GPxDIR = 0: GPx pin is an input GPxDIR = 1: GPx pin is an output |
| CLKOUT6/GP2‡ | AD6 | CLKOUT6 | GP2EN = 0 (disabled) | |
| CLKS2/GP8‡ | AE4 | CLKS2 | GP8EN = 0 (disabled) | |
| GP9/PIDSEL | M3 | None | GPxEN = 0 (disabled) PCI_EN = 0 (disabled)† | To use GP[15:9] as GPIO pins, the PCI needs to be disabled (PCI_EN = 0), the GPxEN bits in the GPIO Enable Register and the GPxDIR bits in the GPIO Direction Register must be properly configured. GPxEN = 1: GPx pin enabled GPxDIR = 0: GPx pin is an input GPxDIR = 1: GPx pin is an output |
| GP10/PCBE3 | L2 | | | |
| GP11/PREQ | F1 | | | |
| GP12/P $\overline{\text{GNT}}$ | J3 | | | |
| GP13/PINTA | G4 | | | |
| GP14/PCLK | F2 | | | |
| GP15/P $\overline{\text{RST}}$ | G3 | | | |
| DX1/UXADDR4 | AB11 | DX1 | UTOPIA_EN (BEA11) = 0 (disabled)† | By default, McBSP1 is enabled upon reset (UTOPIA is disabled). To enable the UTOPIA peripheral, an external pullup resistor (1 k Ω) must be provided on the BEA11 pin (setting UTOPIA_EN = 1 at reset). |
| FSX1/UXADDR3 | AB13 | FSX1 | | |
| FSR1/UXADDR2 | AC9 | FSR1 | | |
| DR1/UXADDR1 | AF11 | DR1 | | |
| CLKX1/URADDR4 | AB12 | CLKX1 | | |
| CLKS1/URADDR3 | AC8 | CLKS1 | | |
| CLKR1/URADDR2 | AC10 | CLKR1 | | |
| CLKX2/XSP_CLK | AC2 | CLKX2 | PCI_EN = 0 (disabled)† | By default, HPI is enabled upon reset (PCI is disabled). To enable the PCI peripheral an external pullup resistor (1 k Ω) must be provided on the PCI_EN pin (setting PCI_EN = 1 at reset). |
| DR2/XSP_DI | AB3 | DR2 | | |
| DX2/XSP_DO | AA2 | DX2 | | |
| HD[31:0]/AD[31:0] | § | HD[31:0] | | |
| HAS/PPAR | T3 | HAS | | |
| HCNTL1/PDEVSEL | R1 | HCNTL1 | | |
| HCNTL0/PSTOP | T4 | HCNTL0 | | |
| HDS1/PSERR | T1 | HDS1 | | |
| HDS2/PCBE1 | T2 | HDS2 | | |
| HR/ $\overline{\text{W}}$ /PCBE2 | P1 | HR/ $\overline{\text{W}}$ | | |
| HHWIL/PTRDY | R3 | HHWIL (HPI16 only) | | |
| HINT/PFRAME | R4 | HINT | | |
| HCS/PPERR | R2 | HCS | | |
| HRDY/PIRDY | P4 | HRDY | | |

† For the C6415 and C6416 devices, all other standalone UTOPIA and PCI pins are tied-off internally (pins in Hi-Z) when the peripheral is disabled [UTOPIA_EN (BEA11) = 0 or PCI_EN = 0].

‡ The C6414 device does not support the PCI and UTOPIA peripherals. These are the **only** multiplexed pins on the C6414 device, all other pins are standalone peripheral functions and are not muxed.

§ For the HD[31:0]/AD[31:0] multiplexed pins pin numbers, see the *Terminal Functions* table.

ADVANCE INFORMATION



TMS320C6414, TMS320C6415, TMS320C6416 FIXED-POINT DIGITAL SIGNAL PROCESSORS

SPRS146L – FEBRUARY 2001 – REVISED JULY 2004

Terminal Functions

| SIGNAL NAME | NO. | TYPE† | IPD/ IPU‡ | DESCRIPTION | | | | | | | | | | |
|--------------------------------|---|-------|--------------|---|-----------------|------------------|----|--------------------------------------|----|----------|----|----------|----|---|
| CLOCK/PLL CONFIGURATION | | | | | | | | | | | | | | |
| CLKIN | H4 | I | IPD | Clock Input. This clock is the input to the on-chip PLL. | | | | | | | | | | |
| CLKOUT4/GP1§ | AE6 | I/O/Z | IPD | Clock output at 1/4 of the device speed (O/Z) [default] or this pin can be programmed as a GPIO 1 pin (I/O/Z). | | | | | | | | | | |
| CLKOUT6/GP2§ | AD6 | I/O/Z | IPD | Clock output at 1/6 of the device speed (O/Z) [default] or this pin can be programmed as a GPIO 2 pin (I/O/Z). | | | | | | | | | | |
| CLKMODE1 | G1 | I | IPD | Clock mode select <ul style="list-style-type: none"> • Selects whether the CPU clock frequency = input clock frequency x1 (Bypass), x6, or x12. For more details on the CLKMODE pins and the PLL multiply factors, see the Clock PLL section of this data sheet. | | | | | | | | | | |
| CLKMODE0 | H2 | I | IPD | | | | | | | | | | | |
| PLLV¶ | J6 | A# | | PLL voltage supply | | | | | | | | | | |
| JTAG EMULATION | | | | | | | | | | | | | | |
| TMS | AB16 | I | IPU | JTAG test-port mode select | | | | | | | | | | |
| TDO | AE19 | O/Z | IPU | JTAG test-port data out | | | | | | | | | | |
| TDI | AF18 | I | IPU | JTAG test-port data in | | | | | | | | | | |
| TCK | AF16 | I | IPU | JTAG test-port clock | | | | | | | | | | |
| $\overline{\text{TRST}}$ | AB15 | I | IPD | JTAG test-port reset. For IEEE 1149.1 JTAG compatibility, see the IEEE 1149.1 JTAG Compatibility Statement section of this data sheet. | | | | | | | | | | |
| EMU11 | AC18 | I/O/Z | IPU | Emulation pin 11. Reserved for future use, leave unconnected. | | | | | | | | | | |
| EMU10 | AD18 | I/O/Z | IPU | Emulation pin 10. Reserved for future use, leave unconnected. | | | | | | | | | | |
| EMU9 | AE18 | I/O/Z | IPU | Emulation pin 9. Reserved for future use, leave unconnected. | | | | | | | | | | |
| EMU8 | AC17 | I/O/Z | IPU | Emulation pin 8. Reserved for future use, leave unconnected. | | | | | | | | | | |
| EMU7 | AF17 | I/O/Z | IPU | Emulation pin 7. Reserved for future use, leave unconnected. | | | | | | | | | | |
| EMU6 | AD17 | I/O/Z | IPU | Emulation pin 6. Reserved for future use, leave unconnected. | | | | | | | | | | |
| EMU5 | AE17 | I/O/Z | IPU | Emulation pin 5. Reserved for future use, leave unconnected. | | | | | | | | | | |
| EMU4 | AC16 | I/O/Z | IPU | Emulation pin 4. Reserved for future use, leave unconnected. | | | | | | | | | | |
| EMU3 | AD16 | I/O/Z | IPU | Emulation pin 3. Reserved for future use, leave unconnected. | | | | | | | | | | |
| EMU2 | AE16 | I/O/Z | IPU | Emulation pin 2. Reserved for future use, leave unconnected. | | | | | | | | | | |
| EMU1 EMU0 | AC15 AF15 | I/O/Z | IPU | Emulation [1:0] pins <ul style="list-style-type: none"> • Select the device functional mode of operation <table style="margin-left: 20px; border-collapse: collapse;"> <tr> <td style="border-bottom: 1px solid black; padding: 2px;"><u>EMU[1:0]</u></td> <td style="border-bottom: 1px solid black; padding: 2px;"><u>Operation</u></td> </tr> <tr> <td style="padding: 2px;">00</td> <td style="padding: 2px;">Boundary Scan/Normal Mode (see Note)</td> </tr> <tr> <td style="padding: 2px;">01</td> <td style="padding: 2px;">Reserved</td> </tr> <tr> <td style="padding: 2px;">10</td> <td style="padding: 2px;">Reserved</td> </tr> <tr> <td style="padding: 2px;">11</td> <td style="padding: 2px;">Emulation/Normal Mode [default] (see the IEEE 1149.1 JTAG Compatibility Statement section of this data sheet)</td> </tr> </table> Normal mode refers to the DSPs normal operational mode, when the DSP is free running. The DSP can be placed in normal operational mode when the EMU[1:0] pins are configured for either Boundary Scan or Emulation. Note: When the EMU[1:0] pins are configured for Boundary Scan mode, the internal pulldown (IPD) on the $\overline{\text{TRST}}$ signal must not be opposed in order to operate in Normal mode. For the Boundary Scan mode pulldown EMU[1:0] pins with a dedicated 1-k Ω resistor. | <u>EMU[1:0]</u> | <u>Operation</u> | 00 | Boundary Scan/Normal Mode (see Note) | 01 | Reserved | 10 | Reserved | 11 | Emulation/Normal Mode [default] (see the IEEE 1149.1 JTAG Compatibility Statement section of this data sheet) |
| <u>EMU[1:0]</u> | <u>Operation</u> | | | | | | | | | | | | | |
| 00 | Boundary Scan/Normal Mode (see Note) | | | | | | | | | | | | | |
| 01 | Reserved | | | | | | | | | | | | | |
| 10 | Reserved | | | | | | | | | | | | | |
| 11 | Emulation/Normal Mode [default] (see the IEEE 1149.1 JTAG Compatibility Statement section of this data sheet) | | | | | | | | | | | | | |

† I = Input, O = Output, Z = High impedance, S = Supply voltage, GND = Ground

‡ IPD = Internal pulldown, IPU = Internal pullup. (These IPD/IPU signal pins feature a 30-k Ω IPD or IPU resistor. To pull up a signal to the opposite supply rail, a 1-k Ω resistor should be used.)

§ These pins are multiplexed pins. For more details, see the Device Configurations section of this data sheet.

¶ PLLV is not part of external voltage supply. See the Clock PLL section for information on how to connect this pin.

A = Analog signal (PLL Filter)

ADVANCE INFORMATION



TMS320C6414, TMS320C6415, TMS320C6416 FIXED-POINT DIGITAL SIGNAL PROCESSORS

SPRS146L – FEBRUARY 2001 – REVISED JULY 2004

Terminal Functions (Continued)

| SIGNAL NAME | NO. | TYPE† | IPD/ IPU‡ | DESCRIPTION |
|--|-----|-------|---|---|
| RESETS, INTERRUPTS, AND GENERAL-PURPOSE INPUT/OUTPUTS | | | | |
| RESET | AC7 | I | | Device reset |
| NMI | B4 | I | IPD | Nonmaskable interrupt, edge-driven (rising edge) |
| GP7/EXT_INT7 | AF4 | I/O/Z | IPU | General-purpose input/output (GPIO) pins (I/O/Z) or external interrupts (input only). The default after reset setting is GPIO enabled as input-only. <ul style="list-style-type: none"> When these pins function as External Interrupts [by selecting the corresponding interrupt enable register bit (IER.[7:4])], they are edge-driven and the polarity can be independently selected via the External Interrupt Polarity Register bits (EXTPOL.[3:0]). |
| GP6/EXT_INT6 | AD5 | | | |
| GP5/EXT_INT5 | AE5 | | | |
| GP4/EXT_INT4 | AF5 | | | |
| GP15/ $\overline{\text{PRST}}\S$ | G3 | I/O/Z | | General-purpose input/output (GPIO) 15 pin (I/O/Z) or PCI reset (I). No function at default. |
| GP14/ $\overline{\text{PCLK}}\S$ | F2 | | GPIO 14 pin (I/O/Z) or PCI clock (I). No function at default. | |
| GP13/ $\overline{\text{PINTA}}\S$ | G4 | | GPIO 13 pin (I/O/Z) or PCI interrupt A (O/Z). No function at default. | |
| GP12/ $\overline{\text{PGNT}}\S$ | J3 | | GPIO 12 pin (I/O/Z) or PCI bus grant (I). No function at default. | |
| GP11/ $\overline{\text{PREQ}}\S$ | F1 | | GPIO 11 pin (I/O/Z) or PCI bus request (O/Z). No function at default. | |
| GP10/ $\overline{\text{PCBE3}}\S$ | L2 | | GPIO 10 pin (I/O/Z) or PCI command/byte enable 3 (I/O/Z). No function at default. | |
| GP9/ $\overline{\text{PIDSEL}}\S$ | M3 | | GPIO 9 pin (I/O/Z) or PCI initialization device select (I). No function at default. | |
| GP3 | AC6 | | IPD | GPIO 3 pin (I/O/Z). The default after reset setting is GPIO 3 enabled as input-only. |
| GP0 | AF6 | | IPD | GPIO 0 pin. The general-purpose I/O 0 pin (GPIO 0) (I/O/Z) can be programmed as GPIO 0 (input only) [default] or as GPIO 0 (output only) pin or output as a general-purpose interrupt (GP0INT) signal (output only). |
| CLKS2/GP8 $\S\ddagger$ | AE4 | | I/O/Z | IPD |
| CLKOUT6/GP2 $\S\ddagger$ | AD6 | I/O/Z | IPD | Clock output at 1/6 of the device speed (O/Z) [default] or this pin can be programmed as a GPIO 2 pin (I/O/Z). |
| CLKOUT4/GP1 $\S\ddagger$ | AE6 | I/O/Z | IPD | Clock output at 1/4 of the device speed (O/Z) [default] or this pin can be programmed as a GPIO 1 pin (I/O/Z). |
| HOST-PORT INTERFACE (HPI) [C64x] or PERIPHERAL COMPONENT INTERCONNECT (PCI) [C6415 or C6416 devices only] | | | | |
| PCI_EN | AA4 | I | IPD | PCI enable pin. This pin controls the selection (enable/disable) of the HPI and GP[15:9], or PCI peripherals (for the C6415 and C6416 devices). This pin works in conjunction with the McBSP2_EN pin to enable/disable other peripherals (for more details, see the Device Configurations section of this data sheet). The C6414 device does <i>not</i> support the PCI peripheral; for proper device operation, do <i>not</i> oppose the internal pulldown (IPD) on this pin. |
| $\overline{\text{HINT}}/\overline{\text{PFRAME}}\S$ | R4 | I/O/Z | | Host interrupt from DSP to host (O) [default] or PCI frame (I/O/Z) |
| HCNTL1/ $\overline{\text{PDEVSEL}}\S$ | R1 | I/O/Z | | Host control – selects between control, address, or data registers (I) [default] or PCI device select (I/O/Z). |
| HCNTL0/ $\overline{\text{PSTOP}}\S$ | T4 | I/O/Z | | Host control – selects between control, address, or data registers (I) [default] or PCI stop (I/O/Z) |
| HHWIL/ $\overline{\text{PTRDY}}\S$ | R3 | I/O/Z | | Host half-word select – first or second half-word (not necessarily high or low order) [For HPI16 bus width selection only] (I) [default] or PCI target ready (I/O/Z) |
| $\overline{\text{HR}}/\overline{\text{PCBE2}}\S$ | P1 | I/O/Z | | Host read or write select (I) [default] or PCI command/byte enable 2 (I/O/Z) |

† I = Input, O = Output, Z = High impedance, S = Supply voltage, GND = Ground

‡ IPD = Internal pulldown, IPU = Internal pullup. (These IPD/IPU signal pins feature a 30-k Ω IPD or IPU resistor. To pull up a signal to the opposite supply rail, a 1-k Ω resistor should be used.)

§ For the C6415 and C6416 devices, these pins are multiplexed pins. For more details, see the Device Configurations section of this data sheet. The C6414 device does *not* support the PCI or UTOPIA peripherals; therefore, these muxed peripheral pins are standalone peripheral functions for this device.

¶ For the C6414 device, only these pins are multiplexed pins.

ADVANCE INFORMATION



TMS320C6414, TMS320C6415, TMS320C6416 FIXED-POINT DIGITAL SIGNAL PROCESSORS

SPRS146L – FEBRUARY 2001 – REVISED JULY 2004

Terminal Functions (Continued)

| SIGNAL NAME | NO. | TYPE† | IPD/ IPU‡ | DESCRIPTION |
|--|-----|-------|-----------|---|
| HOST-PORT INTERFACE (HPI) [C64x] or PERIPHERAL COMPONENT INTERCONNECT (PCI) [C6415 or C6416 devices only] (CONTINUED) | | | | |
| HAS/PPAR§ | T3 | I/O/Z | | Host address strobe (I) [default] or PCI parity (I/O/Z) |
| HCS/PPERR§ | R2 | I/O/Z | | Host chip select (I) [default] or PCI parity error (I/O/Z) |
| HDS1/PSERR§ | T1 | I/O/Z | | Host data strobe 1 (I) [default] or PCI system error (I/O/Z) |
| HDS2/PCBE1§ | T2 | I/O/Z | | Host data strobe 2 (I) [default] or PCI command/byte enable 1 (I/O/Z) |
| HRDY/PIRDY§ | P4 | I/O/Z | | Host ready from DSP to host (O) [default] or PCI initiator ready (I/O/Z). |
| HD31/AD31§ | J2 | I/O/Z | | <p>Host-port data (I/O/Z) [default] (C64x) or PCI data-address bus (I/O/Z) [C6415 and C6416]</p> <p>As HPI data bus (PCI_EN pin = 0)</p> <ul style="list-style-type: none"> • Used for transfer of data, address, and control • Host-Port bus width user-configurable at device reset via a 10-kΩ resistor pullup/pulldown resistor on the HD5 pin: <p>HD5 pin = 0: HPI operates as an HPI16. (HPI bus is 16 bits wide. HD[15:0] pins are used and the remaining HD[31:16] pins are reserved pins in the high-impedance state.)</p> <p>HD5 pin = 1: HPI operates as an HPI32. (HPI bus is 32 bits wide. All HD[31:0] pins are used for host-port operations.)</p> <p>As PCI data-address bus (PCI_EN pin = 1) [C6415 and C6416 devices only]</p> <ul style="list-style-type: none"> • Used for transfer of data and address <p>The C6414 device does <i>not</i> support the PCI peripheral; therefore, the HPI peripheral pins are standalone peripheral functions, not muxed.</p> |
| HD30/AD30§ | K3 | | | |
| HD29/AD29§ | J1 | | | |
| HD28/AD28§ | K4 | | | |
| HD27/AD27§ | K2 | | | |
| HD26/AD26§ | L3 | | | |
| HD25/AD25§ | K1 | | | |
| HD24/AD24§ | L4 | | | |
| HD23/AD23§ | L1 | | | |
| HD22/AD22§ | M4 | | | |
| HD21/AD21§ | M2 | | | |
| HD20/AD20§ | N4 | | | |
| HD19/AD19§ | M1 | | | |
| HD18/AD18§ | N5 | | | |
| HD17/AD17§ | N1 | | | |
| HD16/AD16§ | P5 | | | |
| HD15/AD15§ | U4 | | | |
| HD14/AD14§ | U1 | | | |
| HD13/AD13§ | U3 | | | |
| HD12/AD12§ | U2 | | | |
| HD11/AD11§ | V4 | | | |
| HD10/AD10§ | V1 | | | |
| HD9/AD9§ | V3 | | | |
| HD8/AD8§ | V2 | | | |
| HD7/AD7§ | W2 | | | |
| HD6/AD6§ | W4 | | | |
| HD5/AD5§ | Y1 | | | |
| HD4/AD4§ | Y3 | | | |
| HD3/AD3§ | Y2 | | | |
| HD2/AD2§ | Y4 | | | |
| HD1/AD1§ | AA1 | | | |
| HD0/AD0§ | AA3 | | | |

† I = Input, O = Output, Z = High impedance, S = Supply voltage, GND = Ground

‡ IPD = Internal pulldown, IPU = Internal pullup. (These IPD/IPU signal pins feature a 30-kΩ IPD or IPU resistor. To pull up a signal to the opposite supply rail, a 1-kΩ resistor should be used.)

§ For the C6415 and C6416 devices, these pins are multiplexed pins. For more details, see the Device Configurations section of this data sheet. The C6414 device does *not* support the PCI or UTOPIA peripherals; therefore, these muxed peripheral pins are standalone peripheral functions for this device.

ADVANCE INFORMATION



TMS320C6414, TMS320C6415, TMS320C6416 FIXED-POINT DIGITAL SIGNAL PROCESSORS

SPRS146L – FEBRUARY 2001 – REVISED JULY 2004

Terminal Functions (Continued)

| SIGNAL NAME | NO. | TYPET | IPD/ IPU‡ | DESCRIPTION |
|--|-----|-------|---|---|
| HOST-PORT INTERFACE (HPI) [C64x] or PERIPHERAL COMPONENT INTERCONNECT (PCI) [C6415 or C6416 devices only] (CONTINUED) | | | | |
| $\overline{\text{PCBE0}}$ | W3 | I/O/Z | | PCI command/byte enable 0 (I/O/Z). When PCI is disabled (PCI_EN = 0), this pin is tied-off. For the C6414 device this pin is "Reserved (leave unconnected, do not connect to power or ground)." |
| XSP_CS | AD1 | O | IPD | PCI serial interface chip select (O). When PCI is disabled (PCI_EN = 0), this pin is tied-off. For the C6414 device this pin is "Reserved (leave unconnected, do not connect to power or ground)." |
| CLKX2/ XSP_CLK§ | AC2 | I/O/Z | IPD | McBSP2 transmit clock (I/O/Z) [default] or PCI serial interface clock (O) (PCI_EN = 1). |
| DR2/XSP_DI§ | AB3 | I | IPU | McBSP2 receive data (I) [default] or PCI serial interface data in (I). In PCI mode (PCI_EN = 1), this pin is connected to the output data pin of the serial PROM. |
| DX2/XSP_DO§ | AA2 | O/Z | IPU | McBSP2 transmit data (O/Z) [default] or PCI serial interface data out (O). In PCI mode (PCI_EN = 1), this pin is connected to the input data pin of the serial PROM. |
| GP15/ $\overline{\text{PRST}}§$ | G3 | I/O/Z | | General-purpose input/output (GPIO) 15 pin (I/O/Z) or PCI reset (I). No function at default. |
| GP14/ $\overline{\text{PCLK}}§$ | F2 | | GPIO 14 pin (I/O/Z) or PCI clock (I). No function at default. | |
| GP13/ $\overline{\text{PINTA}}§$ | G4 | | GPIO 13 pin (I/O/Z) or PCI interrupt A (O/Z). No function at default. | |
| GP12/ $\overline{\text{PGNT}}§$ | J3 | | GPIO 12 pin (I/O/Z) or PCI bus grant (I). No function at default. | |
| GP11/ $\overline{\text{PREQ}}§$ | F1 | | GPIO 11 pin (I/O/Z) or PCI bus request (O/Z). No function at default. | |
| GP10/ $\overline{\text{PCBE3}}§$ | L2 | | GPIO 10 pin (I/O/Z) or PCI command/byte enable 3 (I/O/Z). No function at default. | |
| GP9/ $\overline{\text{PIDSEL}}§$ | M3 | | GPIO 9 pin (I/O/Z) or PCI initialization device select (I). No function at default. | |
| EMIFA (64-bit) – CONTROL SIGNALS COMMON TO ALL TYPES OF MEMORY * | | | | |
| $\overline{\text{ACE3}}$ | L26 | O/Z | IPU | EMIFA memory space enables <ul style="list-style-type: none"> Enabled by bits 28 through 31 of the word address Only one pin is asserted during any external data access |
| $\overline{\text{ACE2}}$ | K23 | O/Z | IPU | |
| $\overline{\text{ACE1}}$ | K24 | O/Z | IPU | |
| $\overline{\text{ACE0}}$ | K25 | O/Z | IPU | |
| $\overline{\text{ABE7}}$ | T23 | O/Z | IPU | EMIFA byte-enable control <ul style="list-style-type: none"> Decoded from the low-order address bits. The number of address bits or byte enables used depends on the width of external memory. Byte-write enables for most types of memory Can be directly connected to SDRAM read and write mask signal (SDQM) |
| $\overline{\text{ABE6}}$ | T24 | O/Z | IPU | |
| $\overline{\text{ABE5}}$ | R25 | O/Z | IPU | |
| $\overline{\text{ABE4}}$ | R26 | O/Z | IPU | |
| $\overline{\text{ABE3}}$ | M25 | O/Z | IPU | |
| $\overline{\text{ABE2}}$ | M26 | O/Z | IPU | |
| $\overline{\text{ABE1}}$ | L23 | O/Z | IPU | |
| $\overline{\text{ABE0}}$ | L24 | O/Z | IPU | |
| $\overline{\text{APDT}}$ | M22 | O/Z | IPU | EMIFA peripheral data transfer, allows direct transfer between external peripherals |

† I = Input, O = Output, Z = High impedance, S = Supply voltage, GND = Ground

‡ IPD = Internal pulldown, IPU = Internal pullup. (These IPD/IPU signal pins feature a 30-k Ω IPD or IPU resistor. To pull up a signal to the opposite supply rail, a 1-k Ω resistor should be used.)

§ For the C6415 and C6416 devices, these pins are multiplexed pins. For more details, see the Device Configurations section of this data sheet. The C6414 device does *not* support the PCI or UTOPIA peripherals; therefore, these muxed peripheral pins are standalone peripheral functions for this device.

|| These C64x™ devices have two EMIFs (64-bit EMIFA and 16-bit EMIFB). The prefix "A" in front of a signal name indicates it is an EMIFA signal whereas a prefix "B" in front of a signal name indicates it is an EMIFB signal. Throughout the rest of this document, in generic EMIF areas of discussion, the prefix "A" or "B" may be omitted from the signal name.

* To maintain signal integrity for the EMIF signals, serial termination resistors should be inserted into all EMIF output signal lines.

ADVANCE INFORMATION



TMS320C6414, TMS320C6415, TMS320C6416 FIXED-POINT DIGITAL SIGNAL PROCESSORS

SPRS146L – FEBRUARY 2001 – REVISED JULY 2004

Terminal Functions (Continued)

| SIGNAL NAME | NO. | TYPE† | IPD/ IPU‡ | DESCRIPTION |
|--|-----|-------|--------------|---|
| EMIFA (64-BIT) – BUS ARBITRATION * | | | | |
| <u>AHOLDA</u> | N22 | O | IPU | EMIFA hold-request-acknowledge to the host |
| <u>AHOLD</u> | V23 | I | IPU | EMIFA hold request from the host |
| ABUSREQ | P22 | O | IPU | EMIFA bus request output |
| EMIFA (64-BIT) – ASYNCHRONOUS/SYNCHRONOUS MEMORY CONTROL * | | | | |
| AECLKIN | H25 | I | IPD | EMIFA external input clock. The EMIFA input clock (AECLKIN, CPU/4 clock, or CPU/6 clock) is selected at reset via the pullup/pulldown resistors on the BEA[17:16] pins. AECLKIN is the default for the EMIFA input clock. |
| AECLKOUT2 | J23 | O/Z | IPD | EMIFA output clock 2. Programmable to be EMIFA input clock (AECLKIN, CPU/4 clock, or CPU/6 clock) frequency divided-by-1, -2, or -4. |
| AECLKOUT1 | J26 | O/Z | IPD | EMIFA output clock 1 [at EMIFA input clock (AECLKIN, CPU/4 clock, or CPU/6 clock) frequency]. |
| <u>AARE/</u> <u>ASDCAS/</u> <u>ASADS/ASRE</u> | J25 | O/Z | IPU | EMIFA asynchronous memory read-enable/SDRAM column-address strobe/programmable synchronous interface-address strobe or read-enable <ul style="list-style-type: none"> • For programmable synchronous interface, the <u>RENEN</u> field in the CE Space Secondary Control Register (CExSEC) selects between <u>ASADS</u> and <u>ASRE</u>: If <u>RENEN</u> = 0, then the <u>ASADS/ASRE</u> signal functions as the <u>ASADS</u> signal. If <u>RENEN</u> = 1, then the <u>ASADS/ASRE</u> signal functions as the <u>ASRE</u> signal. |
| <u>AAOE/</u> <u>ASDRAS/</u> <u>ASOE</u> | J24 | O/Z | IPU | EMIFA asynchronous memory output-enable/SDRAM row-address strobe/programmable synchronous interface output-enable |
| <u>AAWE/</u> <u>ASDWE/</u> <u>ASWE</u> | K26 | O/Z | IPU | EMIFA asynchronous memory write-enable/SDRAM write-enable/programmable synchronous interface write-enable |
| ASDCKE | L25 | O/Z | IPU | EMIFA SDRAM clock-enable (used for self-refresh mode). [EMIFA module only.] <ul style="list-style-type: none"> • If SDRAM is not in system, ASDCKE can be used as a general-purpose output. |
| <u>ASOE3</u> | R22 | O/Z | IPU | EMIFA synchronous memory output-enable for <u>ACE3</u> (for glueless FIFO interface) |
| AARDY | L22 | I | IPU | Asynchronous memory ready input |
| EMIFA (64-BIT) – ADDRESS * | | | | |
| AEA22 | T22 | O/Z | IPD | EMIFA external address (doubleword address) |
| AEA21 | V24 | | | |
| AEA20 | V25 | | | |
| AEA19 | V26 | | | |
| AEA18 | U23 | | | |
| AEA17 | U24 | | | |
| AEA16 | U25 | | | |
| AEA15 | U26 | | | |
| AEA14 | T25 | | | |
| AEA13 | T26 | | | |
| AEA12 | R23 | | | |
| AEA11 | R24 | | | |

† I = Input, O = Output, Z = High impedance, S = Supply voltage, GND = Ground

‡ IPD = Internal pulldown, IPU = Internal pullup. (These IPD/IPU signal pins feature a 30-kΩ IPD or IPU resistor. To pull up a signal to the opposite supply rail, a 1-kΩ resistor should be used.)

|| These C64x™ devices have two EMIFs (64-bit EMIFA and 16-bit EMIFB). The prefix “A” in front of a signal name indicates it is an EMIFA signal whereas a prefix “B” in front of a signal name indicates it is an EMIFB signal. Throughout the rest of this document, in generic EMIF areas of discussion, the prefix “A” or “B” may be omitted from the signal name.

* To maintain signal integrity for the EMIF signals, serial termination resistors should be inserted into all EMIF output signal lines.

ADVANCE INFORMATION



TMS320C6414, TMS320C6415, TMS320C6416 FIXED-POINT DIGITAL SIGNAL PROCESSORS

SPRS146L – FEBRUARY 2001 – REVISED JULY 2004

Terminal Functions (Continued)

| SIGNAL NAME | NO. | TYPE† | IPD/ IPU‡ | DESCRIPTION |
|--|------|-------|-----------|---|
| EMIFA (64-BIT) – ADDRESS * (CONTINUED) | | | | |
| AEA10 | P23 | O/Z | IPD | EMIFA external address (doubleword address) |
| AEA9 | P24 | | | |
| AEA8 | P26 | | | |
| AEA7 | N23 | | | |
| AEA6 | N24 | | | |
| AEA5 | N26 | | | |
| AEA4 | M23 | | | |
| AEA3 | M24 | | | |
| EMIFA (64-bit) – DATA * | | | | |
| AED63 | AF24 | I/O/Z | IPU | EMIFA external data |
| AED62 | AF23 | | | |
| AED61 | AE23 | | | |
| AED60 | AE22 | | | |
| AED59 | AD22 | | | |
| AED58 | AF22 | | | |
| AED57 | AD21 | | | |
| AED56 | AE21 | | | |
| AED55 | AC21 | | | |
| AED54 | AF21 | | | |
| AED53 | AD20 | | | |
| AED52 | AE20 | | | |
| AED51 | AC20 | | | |
| AED50 | AF20 | | | |
| AED49 | AC19 | | | |
| AED48 | AD19 | | | |
| AED47 | W24 | | | |
| AED46 | W23 | | | |
| AED45 | Y26 | | | |
| AED44 | Y23 | | | |
| AED43 | Y25 | | | |
| AED42 | Y24 | | | |
| AED41 | AA26 | | | |
| AED40 | AA23 | | | |
| AED39 | AA25 | | | |
| AED38 | AA24 | | | |
| AED37 | AB26 | | | |

† I = Input, O = Output, Z = High impedance, S = Supply voltage, GND = Ground

‡ IPD = Internal pulldown, IPU = Internal pullup. (These IPD/IPU signal pins feature a 30-kΩ IPD or IPU resistor. To pull up a signal to the opposite supply rail, a 1-kΩ resistor should be used.)

|| These C64x™ devices have two EMIFs (64-bit EMIFA and 16-bit EMIFB). The prefix “A” in front of a signal name indicates it is an EMIFA signal whereas a prefix “B” in front of a signal name indicates it is an EMIFB signal. Throughout the rest of this document, in generic EMIF areas of discussion, the prefix “A” or “B” may be omitted from the signal name.

* To maintain signal integrity for the EMIF signals, serial termination resistors should be inserted into all EMIF output signal lines.

ADVANCE INFORMATION



TMS320C6414, TMS320C6415, TMS320C6416 FIXED-POINT DIGITAL SIGNAL PROCESSORS

SPRS146L – FEBRUARY 2001 – REVISED JULY 2004

Terminal Functions (Continued)

| SIGNAL NAME | NO. | TYPE† | IPD/ IPU‡ | DESCRIPTION |
|---|------|-------|--------------|---------------------|
| EMIFA (64-bit) – DATA * (CONTINUED) | | | | |
| AED36 | AB24 | I/O/Z | IPU | EMIFA external data |
| AED35 | AB25 | | | |
| AED34 | AC25 | | | |
| AED33 | AC26 | | | |
| AED32 | AD26 | | | |
| AED31 | C26 | | | |
| AED30 | D26 | | | |
| AED29 | D25 | | | |
| AED28 | E25 | | | |
| AED27 | E24 | | | |
| AED26 | E26 | | | |
| AED25 | F24 | | | |
| AED24 | F25 | | | |
| AED23 | F23 | | | |
| AED22 | F26 | | | |
| AED21 | G24 | | | |
| AED20 | G25 | | | |
| AED19 | G23 | | | |
| AED18 | G26 | | | |
| AED17 | H23 | | | |
| AED16 | H24 | | | |
| AED15 | C19 | | | |
| AED14 | D19 | | | |
| AED13 | A20 | | | |
| AED12 | D20 | | | |
| AED11 | B20 | | | |
| AED10 | C20 | | | |
| AED9 | A21 | | | |
| AED8 | D21 | | | |
| AED7 | B21 | | | |
| AED6 | C21 | | | |
| AED5 | A22 | | | |
| AED4 | C22 | | | |
| AED3 | B22 | | | |
| AED2 | B23 | | | |
| AED1 | A23 | | | |
| AED0 | A24 | | | |

† I = Input, O = Output, Z = High impedance, S = Supply voltage, GND = Ground

‡ IPD = Internal pulldown, IPU = Internal pullup. (These IPD/IPU signal pins feature a 30-kΩ IPD or IPU resistor. To pull up a signal to the opposite supply rail, a 1-kΩ resistor should be used.)

|| These C64x™ devices have two EMIFs (64-bit EMIFA and 16-bit EMIFB). The prefix "A" in front of a signal name indicates it is an EMIFA signal whereas a prefix "B" in front of a signal name indicates it is an EMIFB signal. Throughout the rest of this document, in generic EMIF areas of discussion, the prefix "A" or "B" may be omitted from the signal name.

* To maintain signal integrity for the EMIF signals, serial termination resistors should be inserted into all EMIF output signal lines.

ADVANCE INFORMATION



TMS320C6414, TMS320C6415, TMS320C6416 FIXED-POINT DIGITAL SIGNAL PROCESSORS

SPRS146L – FEBRUARY 2001 – REVISED JULY 2004

Terminal Functions (Continued)

| SIGNAL NAME | NO. | TYPE† | IPD/ IPU‡ | DESCRIPTION |
|--|-----|-------|-----------|---|
| EMIFB (16-bit) – CONTROL SIGNALS COMMON TO ALL TYPES OF MEMORY * | | | | |
| $\overline{\text{BCE3}}$ | A13 | O/Z | IPU | EMIFB memory space enables <ul style="list-style-type: none"> Enabled by bits 26 through 31 of the word address Only one pin is asserted during any external data access |
| $\overline{\text{BCE2}}$ | C12 | O/Z | IPU | |
| $\overline{\text{BCE1}}$ | B12 | O/Z | IPU | |
| $\overline{\text{BCE0}}$ | A12 | O/Z | IPU | |
| $\overline{\text{BBE1}}$ | D13 | O/Z | IPU | EMIFB byte-enable control <ul style="list-style-type: none"> Decoded from the low-order address bits. The number of address bits or byte enables used depends on the width of external memory. Byte-write enables for most types of memory Can be directly connected to SDRAM read and write mask signal (SDQM) |
| $\overline{\text{BBE0}}$ | C13 | O/Z | IPU | |
| $\overline{\text{BPDT}}$ | E12 | O/Z | IPU | EMIFB peripheral data transfer, allows direct transfer between external peripherals |
| EMIFB (16-BIT) – BUS ARBITRATION * | | | | |
| $\overline{\text{BHOLDA}}$ | E13 | O | IPU | EMIFB hold-request-acknowledge to the host |
| $\overline{\text{BHOLD}}$ | B19 | I | IPU | EMIFB hold request from the host |
| $\overline{\text{BBUSREQ}}$ | E14 | O | IPU | EMIFB bus request output |
| EMIFB (16-BIT) – ASYNCHRONOUS/SYNCHRONOUS MEMORY CONTROL * | | | | |
| $\overline{\text{BECLKIN}}$ | A11 | I | IPD | EMIFB external input clock. The EMIFB input clock ($\overline{\text{BECLKIN}}$, CPU/4 clock, or CPU/6 clock) is selected at reset via the pullup/pulldown resistors on the BEA[15:14] pins. $\overline{\text{BECLKIN}}$ is the default for the EMIFB input clock. |
| $\overline{\text{BECLKOUT2}}$ | D11 | O/Z | IPD | EMIFB output clock 2. Programmable to be EMIFB input clock ($\overline{\text{BECLKIN}}$, CPU/4 clock, or CPU/6 clock) frequency divided by 1, 2, or 4. |
| $\overline{\text{BECLKOUT1}}$ | D12 | O/Z | IPD | EMIFB output clock 1 [at EMIFB input clock ($\overline{\text{BECLKIN}}$, CPU/4 clock, or CPU/6 clock) frequency]. |
| $\overline{\text{BARE/BSDCAS/BSADS/BSRE}}$ | A10 | O/Z | IPU | EMIFB asynchronous memory read-enable/SDRAM column-address strobe/programmable synchronous interface-address strobe or read-enable <ul style="list-style-type: none"> For programmable synchronous interface, the RENEN field in the CE Space Secondary Control Register (CExSEC) selects between $\overline{\text{BSADS}}$ and $\overline{\text{BSRE}}$: If RENEN = 0, then the $\overline{\text{BSADS/BSRE}}$ signal functions as the $\overline{\text{BSADS}}$ signal. If RENEN = 1, then the $\overline{\text{BSADS/BSRE}}$ signal functions as the $\overline{\text{BSRE}}$ signal. |
| $\overline{\text{BAOE/BSDRAS/BSOE}}$ | B11 | O/Z | IPU | EMIFB asynchronous memory output-enable/SDRAM row-address strobe/programmable synchronous interface output-enable |
| $\overline{\text{BAWE/BSDWE/BSWE}}$ | C11 | O/Z | IPU | EMIFB asynchronous memory write-enable/SDRAM write-enable/programmable synchronous interface write-enable |
| $\overline{\text{BSOE3}}$ | E15 | O/Z | IPU | EMIFB synchronous memory output enable for $\overline{\text{BCE3}}$ (for glueless FIFO interface) |
| $\overline{\text{BARDY}}$ | E11 | I | IPU | EMIFB asynchronous memory ready input |

† I = Input, O = Output, Z = High impedance, S = Supply voltage, GND = Ground

‡ IPD = Internal pulldown, IPU = Internal pullup. (These IPD/IPU signal pins feature a 30-k Ω IPD or IPU resistor. To pull up a signal to the opposite supply rail, a 1-k Ω resistor should be used.)

|| These C64x™ devices have two EMIFs (64-bit EMIFA and 16-bit EMIFB). The prefix “A” in front of a signal name indicates it is an EMIFA signal whereas a prefix “B” in front of a signal name indicates it is an EMIFB signal. Throughout the rest of this document, in generic EMIF areas of discussion, the prefix “A” or “B” may be omitted from the signal name.

* To maintain signal integrity for the EMIF signals, serial termination resistors should be inserted into all EMIF output signal lines.

ADVANCE INFORMATION



TMS320C6414, TMS320C6415, TMS320C6416 FIXED-POINT DIGITAL SIGNAL PROCESSORS

SPRS146L – FEBRUARY 2001 – REVISED JULY 2004

Terminal Functions (Continued)

| SIGNAL NAME | NO. | TYPE† | IPD/ IPU‡ | DESCRIPTION |
|------------------------------------|-----|-------|--------------|---|
| EMIFB (16-BIT) – ADDRESS * | | | | |
| BEA20 | E16 | I/O/Z | IPU | <p>EMIFB external address (half-word address) (O/Z)</p> <ul style="list-style-type: none"> • Also controls initialization of DSP modes at reset (I) via pullup/pulldown resistors – Device Endian mode <ul style="list-style-type: none"> BEA20: 0 – Big Endian 1 – Little Endian (default mode) – Boot mode <ul style="list-style-type: none"> BEA[19:18]: 00 – No boot 01 – HPI boot 10 – EMIFB 8-bit ROM boot with default timings (default mode) 11 – Reserved – EMIF clock select <ul style="list-style-type: none"> BEA[17:16]: Clock mode select for EMIFA (AECLKIN_SEL[1:0]) <ul style="list-style-type: none"> 00 – AECLKIN (default mode) 01 – CPU/4 Clock Rate 10 – CPU/6 Clock Rate 11 – Reserved BEA[15:14]: Clock mode select for EMIFB (BECLKIN_SEL[1:0]) <ul style="list-style-type: none"> 00 – BECLKIN (default mode) 01 – CPU/4 Clock Rate 10 – CPU/6 Clock Rate 11 – Reserved – PCI EEPROM Auto-Initialization (EEAI) [C6415 and C6416 devices only] <ul style="list-style-type: none"> BEA13: PCI auto-initialization via external EEPROM If the PCI peripheral is disabled (PCI_EN pin = 0), this pin must not be pulled up. <ul style="list-style-type: none"> 0 – PCI auto-initialization through EEPROM is disabled (default). 1 – PCI auto-initialization through EEPROM is enabled. – UTOPIA Enable (UTOPIA_EN) [C6415 and C6416 devices only] <ul style="list-style-type: none"> BEA11: UTOPIA peripheral enable (functional) <ul style="list-style-type: none"> 0 – UTOPIA disabled (McBSP1 enabled) [default] 1 – UTOPIA enabled (McBSP1 disabled) <p>The C6414 device does not support the PCI and UTOPIA peripherals; for proper device operation, do not oppose the internal pulldowns (IPDs) on the BEA13 and BEA11 pins.</p> <p>Also for proper C6414 device operation, do not oppose the IPDs on the BEA7, BEA8, and BEA9 pins.</p> <p>For proper C6415 device operation, the BEA7 pin must be externally pulled up with a 1-kΩ resistor.</p> <p>For proper C6416 device operation, the BEA8 and BEA9 pins must be externally pulled up with a 1-kΩ resistor.</p> <p>For more details, see the Device Configurations section of this data sheet.</p> |
| BEA19 | D18 | | IPU | |
| BEA18 | C18 | | IPD | |
| BEA17 | B18 | | IPD | |
| BEA16 | A18 | | IPD | |
| BEA15 | D17 | | IPD | |
| BEA14 | C17 | | IPD | |
| BEA13 | B17 | | IPD | |
| BEA12 | A17 | | IPD | |
| BEA11 | D16 | | IPD | |
| BEA10 | C16 | | IPD | |
| BEA9 | B16 | | IPD | |
| BEA8 | A16 | | IPD | |
| BEA7 | D15 | | IPD | |
| BEA6 | C15 | | IPD | |
| BEA5 | B15 | | IPD | |
| BEA4 | A15 | | IPD | |
| BEA3 | D14 | | IPD | |
| BEA2 | C14 | | IPD | |
| BEA1 | A14 | | IPD | |

ADVANCE INFORMATION

† I = Input, O = Output, Z = High impedance, S = Supply voltage, GND = Ground

‡ IPD = Internal pulldown, IPU = Internal pullup. (These IPD/IPU signal pins feature a 30-kΩ IPD or IPU resistor. To pull up a signal to the opposite supply rail, a 1-kΩ resistor should be used.)

|| These C64x™ devices have two EMIFs (64-bit EMIFA and 16-bit EMIFB). The prefix “A” in front of a signal name indicates it is an EMIFA signal whereas a prefix “B” in front of a signal name indicates it is an EMIFB signal. Throughout the rest of this document, in generic EMIF areas of discussion, the prefix “A” or “B” may be omitted from the signal name.

* To maintain signal integrity for the EMIF signals, serial termination resistors should be inserted into all EMIF output signal lines.



TMS320C6414, TMS320C6415, TMS320C6416 FIXED-POINT DIGITAL SIGNAL PROCESSORS

SPRS146L – FEBRUARY 2001 – REVISED JULY 2004

Terminal Functions (Continued)

| SIGNAL NAME | NO. | TYPET | IPD/ IPU‡ | DESCRIPTION |
|---|-----|-------|--------------|--|
| EMIFB (16-bit) – DATA * | | | | |
| BED15 | D7 | I/O/Z | IPU | EMIFB external data |
| BED14 | B6 | | | |
| BED13 | C7 | | | |
| BED12 | A6 | | | |
| BED11 | D8 | | | |
| BED10 | B7 | | | |
| BED9 | C8 | | | |
| BED8 | A7 | | | |
| BED7 | C9 | | | |
| BED6 | B8 | | | |
| BED5 | D9 | | | |
| BED4 | B9 | | | |
| BED3 | C10 | | | |
| BED2 | A9 | | | |
| BED1 | D10 | | | |
| BED0 | B10 | | | |
| MULTICHANNEL BUFFERED SERIAL PORT 2 (McBSP2) | | | | |
| MCBSP2_EN | AF3 | I | IPD | McBSP2 enable pin. This pin works in conjunction with the PCI_EN pin to enable/disable other peripherals (for more details, see the Device Configurations section of this data sheet). |
| CLKS2/GP8§ | AE4 | I/O/Z | IPD | McBSP2 external clock source (CLKS2) [input only] [default] or this pin can also be programmed as a GPIO 8 pin (I/O/Z). |
| CLKR2 | AB1 | I/O/Z | IPD | McBSP2 receive clock. When McBSP2 is disabled (PCI_EN = 1 and MCBSP2_EN pin = 0), this pin is tied-off. |
| CLKX2/ XSP_CLK§ | AC2 | I/O/Z | IPD | McBSP2 transmit clock (I/O/Z) [default] or PCI serial interface clock (O). |
| DR2/XSP_DI§ | AB3 | I | IPU | McBSP2 receive data (I) [default] or PCI serial interface data in (I). In PCI mode, this pin is connected to the output data pin of the serial PROM. |
| DX2/XSP_DO§ | AA2 | O/Z | IPU | McBSP2 transmit data (O/Z) [default] or PCI serial interface data out (O). In PCI mode, this pin is connected to the input data pin of the serial PROM. |
| FSR2 | AC1 | I/O/Z | IPD | McBSP2 receive frame sync. When McBSP2 is disabled (PCI_EN = 1 and MCBSP2_EN pin = 0), this pin is tied-off. |
| FSX2 | AB2 | I/O/Z | IPD | McBSP2 transmit frame sync. When McBSP2 is disabled (PCI_EN = 1 and MCBSP2_EN pin = 0), this pin is tied-off. |

† I = Input, O = Output, Z = High impedance, S = Supply voltage, GND = Ground

‡ IPD = Internal pulldown, IPU = Internal pullup. (These IPD/IPU signal pins feature a 30-kΩ IPD or IPU resistor. To pull up a signal to the opposite supply rail, a 1-kΩ resistor should be used.)

§ For the C6415 and C6416 devices, these pins are multiplexed pins. For more details, see the Device Configurations section of this data sheet. The C6414 device does *not* support the PCI or UTOPIA peripherals; therefore, these muxed peripheral pins except CLKS2/GP8 are standalone peripheral functions for this device.

|| These C64x™ devices have two EMIFs (64-bit EMIFA and 16-bit EMIFB). The prefix “A” in front of a signal name indicates it is an EMIFA signal whereas a prefix “B” in front of a signal name indicates it is an EMIFB signal. Throughout the rest of this document, in generic EMIF areas of discussion, the prefix “A” or “B” may be omitted from the signal name.

* To maintain signal integrity for the EMIF signals, serial termination resistors should be inserted into all EMIF output signal lines.

ADVANCE INFORMATION



TMS320C6414, TMS320C6415, TMS320C6416 FIXED-POINT DIGITAL SIGNAL PROCESSORS

SPRS146L – FEBRUARY 2001 – REVISED JULY 2004

Terminal Functions (Continued)

| SIGNAL NAME | NO. | TYPE† | IPD/ IPU‡ | DESCRIPTION |
|---|------|-------|--------------|---|
| MULTICHANNEL BUFFERED SERIAL PORT 1 (McBSP1) | | | | |
| CLKS1/ URADDR3§ | AC8 | I | | McBSP1 external clock source (as opposed to internal) (I) [default] or UTOPIA receive address 3 pin (I) |
| CLKR1/ URADDR2§ | AC10 | I/O/Z | | McBSP1 receive clock (I/O/Z) [default] or UTOPIA receive address 2 pin (I) |
| CLKX1/ URADDR4§ | AB12 | I/O/Z | | McBSP1 transmit clock (I/O/Z) [default] or UTOPIA receive address 4 pin (I) |
| DR1/ UXADDR1§ | AF11 | I | | McBSP1 receive data (I) [default] or UTOPIA transmit address 1 pin (I) |
| DX1/ UXADDR4§ | AB11 | I/O/Z | | McBSP1 transmit data (O/Z) [default] or UTOPIA transmit address 4 pin (I) |
| FSR1/ UXADDR2§ | AC9 | I/O/Z | | McBSP1 receive frame sync (I/O/Z) [default] or UTOPIA transmit address 2 pin (I) |
| FSX1/ UXADDR3§ | AB13 | I/O/Z | | McBSP1 transmit frame sync (I/O/Z) [default] or UTOPIA transmit address 3 pin (I) |
| MULTICHANNEL BUFFERED SERIAL PORT 0 (McBSP0) | | | | |
| CLKS0 | F4 | I | IPD | McBSP0 external clock source (as opposed to internal) |
| CLKR0 | D1 | I/O/Z | IPD | McBSP0 receive clock |
| CLKX0 | E1 | I/O/Z | IPD | McBSP0 transmit clock |
| DR0 | D2 | I | IPU | McBSP0 receive data |
| DX0 | E2 | O/Z | IPU | McBSP0 transmit data |
| FSR0 | C1 | I/O/Z | IPD | McBSP0 receive frame sync |
| FSX0 | E3 | I/O/Z | IPD | McBSP0 transmit frame sync |
| TIMER 2 | | | | |
| TOUT2 | A4 | O/Z | IPD | Timer 2 or general-purpose output |
| TINP2 | C5 | I | IPD | Timer 2 or general-purpose input |
| TIMER 1 | | | | |
| TOUT1 | B5 | O/Z | IPD | Timer 1 or general-purpose output |
| TINP1 | A5 | I | IPD | Timer 1 or general-purpose input |
| TIMER 0 | | | | |
| TOUT0 | D6 | O/Z | IPD | Timer 0 or general-purpose output |
| TINP0 | C6 | I | IPD | Timer 0 or general-purpose input |

† I = Input, O = Output, Z = High impedance, S = Supply voltage, GND = Ground

‡ IPD = Internal pulldown, IPU = Internal pullup. (These IPD/IPU signal pins feature a 30-k Ω IPD or IPU resistor. To pull up a signal to the opposite supply rail, a 1-k Ω resistor should be used.)

§ For the C6415 and C6416 devices, these pins are multiplexed pins. For more details, see the Device Configurations section of this data sheet. The C6414 device does *not* support the PCI or UTOPIA peripherals; therefore, these muxed peripheral pins are standalone peripheral functions for this device.

ADVANCE INFORMATION



TMS320C6414, TMS320C6415, TMS320C6416 FIXED-POINT DIGITAL SIGNAL PROCESSORS

SPRS146L – FEBRUARY 2001 – REVISED JULY 2004

Terminal Functions (Continued)

| SIGNAL NAME | NO. | TYPE† | IPD/ IPU‡ | DESCRIPTION |
|---|------|-------|-----------|--|
| UNIVERSAL TEST AND OPERATIONS PHY INTERFACE FOR ASYNCHRONOUS TRANSFER MODE (ATM) [UTOPIA SLAVE] [C6415 and C6416 devices only] | | | | |
| UTOPIA SLAVE (ATM CONTROLLER) – TRANSMIT INTERFACE | | | | |
| UXCLK ^ψ | AD11 | I | □ | Source clock for UTOPIA transmit driven by Master ATM Controller. When the UTOPIA peripheral is disabled (UTOPIA_EN [BEA11 pin] = 0), this pin is tied-off. |
| UXCLAV ^ψ | AC14 | O/Z | | Transmit cell available status output signal from UTOPIA Slave. 0 indicates a complete cell is NOT available for transmit 1 indicates a complete cell is available for transmit When the UTOPIA peripheral is disabled (UTOPIA_EN [BEA11 pin] = 0), this pin is tied-off. |
| <u>UXENB</u> ^ψ | AE15 | I | ◇ | UTOPIA transmit interface enable input signal. Asserted by the Master ATM Controller to indicate that the UTOPIA Slave should put out on the Transmit Data Bus the first byte of valid data and the UXSOC signal in the next clock cycle. When the UTOPIA peripheral is disabled (UTOPIA_EN [BEA11 pin] = 0), this pin is tied-off. |
| UXSOC ^ψ | AC13 | O/Z | | Transmit Start-of-Cell signal. This signal is output by the UTOPIA Slave on the rising edge of the UXCLK, indicating that the first valid byte of the cell is available on the 8-bit Transmit Data Bus (UXDATA[7:0]). When the UTOPIA peripheral is disabled (UTOPIA_EN [BEA11 pin] = 0), this pin is tied-off. |
| DX1/ UXADDR4§ | AB11 | I/O/Z | ◇ | McBSP1 [default] or UTOPIA transmit address pins As UTOPIA transmit address pins UXADDR[4:0] (I), UTOPIA_EN (BEA11 pin) = 1: <ul style="list-style-type: none"> 5-bit Slave transmit address input pins driven by the Master ATM Controller to identify and select one of the Slave devices (up to 31 possible) in the ATM System. UXADDR0 pin is tied off when the UTOPIA peripheral is disabled [UTOPIA_EN (BEA11 pin) = 0] For the McBSP1 pin functions (UTOPIA_EN (BEA11 pin) = 0 [default]), see the MULTICHANNEL BUFFERED SERIAL PORT 1 (McBSP1) section of this table. |
| FSX1/ UXADDR3§ | AB13 | I/O/Z | ◇ | McBSP1 [default] or UTOPIA transmit address pins As UTOPIA transmit address pins UXADDR[4:0] (I), UTOPIA_EN (BEA11 pin) = 1: <ul style="list-style-type: none"> 5-bit Slave transmit address input pins driven by the Master ATM Controller to identify and select one of the Slave devices (up to 31 possible) in the ATM System. |
| FSR1/ UXADDR2§ | AC9 | I/O/Z | ◇ | <ul style="list-style-type: none"> UXADDR0 pin is tied off when the UTOPIA peripheral is disabled [UTOPIA_EN (BEA11 pin) = 0] |
| DR1/ UXADDR1§ | AF11 | I | ◇ | For the McBSP1 pin functions (UTOPIA_EN (BEA11 pin) = 0 [default]), see the MULTICHANNEL BUFFERED SERIAL PORT 1 (McBSP1) section of this table. |
| UXADDR0 ^ψ | AE9 | I | ◇ | For the McBSP1 pin functions (UTOPIA_EN (BEA11 pin) = 0 [default]), see the MULTICHANNEL BUFFERED SERIAL PORT 1 (McBSP1) section of this table. |

† I = Input, O = Output, Z = High impedance, S = Supply voltage, GND = Ground

‡ IPD = Internal pulldown, IPU = Internal pullup. (These IPD/IPU signal pins feature a 30-kΩ IPD or IPU resistor. To pull up a signal to the opposite supply rail, a 1-kΩ resistor should be used.)

§ For the C6415 and C6416 devices, these pins are multiplexed pins. For more details, see the Device Configurations section of this data sheet. The C6414 device does *not* support the PCI or UTOPIA peripherals; therefore, these muxed peripheral pins are standalone peripheral functions for this device.

□ For the C6415 and C6416 devices, external pulldowns required: *If* UTOPIA is selected (BEA11 = 1) *and* these pins are connected to other devices, then a 10-kΩ resistor must be used to **externally** pull down each of these pins. If these pins are “no connects”, then only UXCLK and URCLK need to be pulled down and other pulldowns are not necessary.

◇ For the C6415 and C6416 devices, external pullups required: *If* UTOPIA is selected (BEA11 = 1) *and* these pins are connected to other devices, then a 10-kΩ resistor must be used to **externally** pull up each of these pins. If these pins are “no connects”, then the pullups are not necessary.

ψ The C6414 device does not support the UTOPIA peripheral; therefore, these standalone UTOPIA pins are **Reserved** (leave unconnected, **do not** connect to power or ground) with the exception of UXCLK and URCLK which should be connected to a 10-kΩ pulldown resistor (see the square [□] footnote).

ADVANCE INFORMATION



Terminal Functions (Continued)

| SIGNAL NAME | NO. | TYPE† | IPD/ IPU‡ | DESCRIPTION |
|---|------|-------|-----------|---|
| UTOPIA SLAVE (ATM CONTROLLER) – TRANSMIT INTERFACE (CONTINUED) | | | | |
| UXDATA7 ^Ψ | AD10 | O/Z | | 8-bit Transmit Data Bus Using the Transmit Data Bus, the UTOPIA Slave (on the rising edge of the UXCLK) transmits the 8-bit ATM cells to the Master ATM Controller. When the UTOPIA peripheral is disabled (UTOPIA_EN [BEA11 pin] = 0), these pins are tied-off. |
| UXDATA6 ^Ψ | AD9 | | | |
| UXDATA5 ^Ψ | AD8 | | | |
| UXDATA4 ^Ψ | AE8 | | | |
| UXDATA3 ^Ψ | AF9 | | | |
| UXDATA2 ^Ψ | AF7 | | | |
| UXDATA1 ^Ψ | AE7 | | | |
| UXDATA0 ^Ψ | AD7 | | | |
| UTOPIA SLAVE (ATM CONTROLLER) – RECEIVE INTERFACE | | | | |
| URCLK ^Ψ | AD12 | I | □ | Source clock for UTOPIA receive driven by Master ATM Controller. When the UTOPIA peripheral is disabled (UTOPIA_EN [BEA11 pin] = 0), this pin is tied-off. |
| URCLAV ^Ψ | AF14 | O/Z | | Receive cell available status output signal from UTOPIA Slave. 0 indicates NO space is available to receive a cell from Master ATM Controller 1 indicates space is available to receive a cell from Master ATM Controller When the UTOPIA peripheral is disabled (UTOPIA_EN [BEA11 pin] = 0), this pin is tied-off. |
| $\overline{\text{URENB}}^{\Psi}$ | AD15 | I | ◇ | UTOPIA receive interface enable input signal. Asserted by the Master ATM Controller to indicate to the UTOPIA Slave to sample the Receive Data Bus (URDATA[7:0]) and URSOC signal in the next clock cycle or thereafter. When the UTOPIA peripheral is disabled (UTOPIA_EN [BEA11 pin] = 0), this pin is tied-off. |
| URSOC ^Ψ | AB14 | I | □ | Receive Start-of-Cell signal. This signal is output by the Master ATM Controller to indicate to the UTOPIA Slave that the first valid byte of the cell is available to sample on the 8-bit Receive Data Bus (URDATA[7:0]). When the UTOPIA peripheral is disabled (UTOPIA_EN [BEA11 pin] = 0), this pin is tied-off. |
| CLKX1/ URADDR4 [§] | AB12 | I/O/Z | ◇ | McBSP1 [default] or UTOPIA receive address pins As UTOPIA receive address pins URADDR[4:0] (I), UTOPIA_EN (BEA11 pin) = 1: • 5-bit Slave receive address input pins driven by the Master ATM Controller to identify and select one of the Slave devices (up to 31 possible) in the ATM System. • URADDR1 and URADDR0 pins are tied off when the UTOPIA peripheral is disabled [UTOPIA_EN (BEA11 pin) = 0] For the McBSP1 pin functions (UTOPIA_EN (BEA11 pin) = 0 [default]), see the MULTICHANNEL BUFFERED SERIAL PORT 1 (McBSP1) section of this table. |
| CLKS1/ URADDR3 [§] | AC8 | I | ◇ | |
| CLKR1/ URADDR2 [§] | AC10 | I/O/Z | ◇ | |
| URADDR1 ^Ψ | AF10 | I | ◇ | |
| URADDR0 ^Ψ | AE10 | I | ◇ | |

† I = Input, O = Output, Z = High impedance, S = Supply voltage, GND = Ground

‡ IPD = Internal pulldown, IPU = Internal pullup. (These IPD/IPU signal pins feature a 30-kΩ IPD or IPU resistor. To pull up a signal to the opposite supply rail, a 1-kΩ resistor should be used.)

§ These pins are multiplexed pins. For more details, see the Device Configurations section of this data sheet.

□ External pulldowns required: If UTOPIA is selected (BEA11 = 1) and these pins are connected to other devices, then a 10-kΩ resistor must be used to **externally** pull down each of these pins. If these pins are “no connects”, then only UXCLK and URCLK need to be pulled down and other pulldowns are not necessary.

◇ External pullups required: If UTOPIA is selected (BEA11 = 1) and these pins are connected to other devices, then a 10-kΩ resistor must be used to **externally** pull up each of these pins. If these pins are “no connects”, then the pullups are not necessary.

Ψ The C6414 device does not support the UTOPIA peripheral; therefore, these standalone UTOPIA pins are **Reserved** (leave unconnected, **do not** connect to power or ground) with the exception of UXCLK and URCLK which should be connected to a 10-kΩ pulldown resistor (see the square [□] footnote).

TMS320C6414, TMS320C6415, TMS320C6416 FIXED-POINT DIGITAL SIGNAL PROCESSORS

SPRS146L – FEBRUARY 2001 – REVISED JULY 2004

Terminal Functions (Continued)

| SIGNAL NAME | NO. | TYPET | IPD/ IPU‡ | DESCRIPTION |
|--|------|-------|--------------|---|
| UTOPIA SLAVE (ATM CONTROLLER) – RECEIVE INTERFACE (CONTINUED) | | | | |
| URDATA7 ^Ψ | AF12 | I | □ | 8-bit Receive Data Bus. Using the Receive Data Bus, the UTOPIA Slave (on the rising edge of the URCLK) can receive the 8-bit ATM cell data from the Master ATM Controller. When the UTOPIA peripheral is disabled (UTOPIA_EN [BEA11 pin] = 0), these pins are tied-off. |
| URDATA6 ^Ψ | AE11 | | | |
| URDATA5 ^Ψ | AF13 | | | |
| URDATA4 ^Ψ | AC11 | | | |
| URDATA3 ^Ψ | AC12 | | | |
| URDATA2 ^Ψ | AE12 | | | |
| URDATA1 ^Ψ | AD14 | | | |
| URDATA0 ^Ψ | AD13 | | | |
| RESERVED FOR TEST | | | | |
| RSV | G14 | | | Reserved. These pins must be connected directly to CV _{DD} for proper device operation. |
| | H7 | | | |
| | N20 | | | |
| | P7 | | | |
| | Y13 | | | |
| RSV | R6 | | | Reserved. This pin must be connected directly to DV _{DD} for proper device operation. |
| RSV | A3 | | | Reserved (leave unconnected, do not connect to power or ground) |
| | G2 | | | |
| | H3 | | | |
| | J4 | | | |
| | K6 | | | |
| | N3 | | | |
| | P3 | | | |
| | W25 | | | |

† I = Input, O = Output, Z = High impedance, S = Supply voltage, GND = Ground

‡ IPD = Internal pulldown, IPU = Internal pullup. (These IPD/IPU signal pins feature a 30-kΩ IPD or IPU resistor. To pull up a signal to the opposite supply rail, a 1-kΩ resistor should be used.)

□ External pulldowns required: *If* UTOPIA is selected (BEA11 = 1) *and* these pins are connected to other devices, then a 10-kΩ resistor must be used to **externally** pull down each of these pins. If these pins are “no connects”, then only UXCLK and URCLK need to be pulled down and other pulldowns are not necessary.

Ψ The C6414 device does not support the UTOPIA peripheral; therefore, these standalone UTOPIA pins are **Reserved** (leave unconnected, **do not** connect to power or ground) with the exception of UXCLK and URCLK which should be connected to a 10-kΩ pulldown resistor (see the square [□] footnote).

ADVANCE INFORMATION



TMS320C6414, TMS320C6415, TMS320C6416 FIXED-POINT DIGITAL SIGNAL PROCESSORS

SPRS146L – FEBRUARY 2001 – REVISED JULY 2004

Terminal Functions (Continued)

| SIGNAL NAME | NO. | TYPE† | DESCRIPTION |
|----------------------------|-----|-------|--|
| SUPPLY VOLTAGE PINS | | | |
| DVDD | A2 | S | 3.3-V supply voltage (see the Power-Supply Decoupling section of this data sheet) |
| | A25 | | |
| | B1 | | |
| | B14 | | |
| | B26 | | |
| | E7 | | |
| | E8 | | |
| | E10 | | |
| | E17 | | |
| | E19 | | |
| | E20 | | |
| | F3 | | |
| | F9 | | |
| | F12 | | |
| | F15 | | |
| | F18 | | |
| | G5 | | |
| | G22 | | |
| | H5 | | |
| | H22 | | |
| | J21 | | |
| | K5 | | |
| | K22 | | |
| | L5 | | |
| | M5 | | |
| | M6 | | |
| | M21 | | |
| | N2 | | |
| | P25 | | |
| | R5 | | |
| R21 | | | |
| T5 | | | |
| U5 | | | |
| U22 | | | |
| V6 | | | |
| V21 | | | |
| W5 | | | |
| W22 | | | |
| Y5 | | | |
| Y22 | | | |

† I = Input, O = Output, Z = High impedance, S = Supply voltage, GND = Ground

ADVANCE INFORMATION



TMS320C6414, TMS320C6415, TMS320C6416 FIXED-POINT DIGITAL SIGNAL PROCESSORS

SPRS146L – FEBRUARY 2001 – REVISED JULY 2004

Terminal Functions (Continued)

| SIGNAL NAME | | TYPET | DESCRIPTION |
|--|------|-------|--|
| SUPPLY VOLTAGE PINS (CONTINUED) | | | |
| DVDD | AA9 | S | 3.3-V supply voltage (see the Power-Supply Decoupling section of this data sheet) |
| | AA12 | | |
| | AA15 | | |
| | AA18 | | |
| | AB7 | | |
| | AB8 | | |
| | AB10 | | |
| | AB17 | | |
| | AB19 | | |
| | AB20 | | |
| | AE1 | | |
| | AE13 | | |
| | AE26 | | |
| | AF2 | | |
| AF25 | | | |
| CVDD | A1 | S | 1.2-V supply voltage (-5E0 device) 1.25-V supply voltage (A-5E0 device) 1.4 V supply voltage (-6E3, A-6E3, -7E3 devices) (see the Power-Supply Decoupling section of this data sheet) |
| | A26 | | |
| | B2 | | |
| | B25 | | |
| | C3 | | |
| | C24 | | |
| | D4 | | |
| | D23 | | |
| | E5 | | |
| | E22 | | |
| | F6 | | |
| | F7 | | |
| | F20 | | |
| | F21 | | |
| | G6 | | |
| | G7 | | |
| | G8 | | |
| | G10 | | |
| G11 | | | |
| G13 | | | |
| G16 | | | |
| G17 | | | |
| G19 | | | |
| G20 | | | |

† I = Input, O = Output, Z = High impedance, S = Supply voltage, GND = Ground

ADVANCE INFORMATION



TMS320C6414, TMS320C6415, TMS320C6416 FIXED-POINT DIGITAL SIGNAL PROCESSORS

SPRS146L – FEBRUARY 2001 – REVISED JULY 2004

Terminal Functions (Continued)

| SIGNAL | | TYPE† | DESCRIPTION |
|--|------|-------|--|
| NAME | NO. | | |
| SUPPLY VOLTAGE PINS (CONTINUED) | | | |
| CVDD | G21 | S | 1.2-V supply voltage (-5E0 device) 1.25-V supply voltage (A-5E0 device) 1.4 V supply voltage (-6E3, A-6E3, -7E3 devices) (see the Power-Supply Decoupling section of this data sheet) |
| | H20 | | |
| | K7 | | |
| | K20 | | |
| | L7 | | |
| | L20 | | |
| | N7 | | |
| | P20 | | |
| | T7 | | |
| | T20 | | |
| | U7 | | |
| | U20 | | |
| | W7 | | |
| | W20 | | |
| | Y6 | | |
| | Y7 | | |
| | Y8 | | |
| | Y10 | | |
| | Y11 | | |
| | Y14 | | |
| | Y16 | | |
| | Y17 | | |
| | Y19 | | |
| | Y20 | | |
| | Y21 | | |
| | AA6 | | |
| | AA7 | | |
| | AA20 | | |
| | AA21 | | |
| | AB5 | | |
| AB22 | | | |
| AC4 | | | |
| AC23 | | | |
| AD3 | | | |
| AD24 | | | |
| AE2 | | | |
| AE25 | | | |
| AF1 | | | |
| AF26 | | | |

† I = Input, O = Output, Z = High impedance, S = Supply voltage, GND = Ground

ADVANCE INFORMATION



**TMS320C6414, TMS320C6415, TMS320C6416
FIXED-POINT DIGITAL SIGNAL PROCESSORS**

SPRS146L – FEBRUARY 2001 – REVISED JULY 2004

Terminal Functions (Continued)

| SIGNAL NAME | | TYPET | DESCRIPTION |
|--------------------|-----|-------|-------------|
| GROUND PINS | | | |
| VSS | A8 | GND | Ground pins |
| | A19 | | |
| | B3 | | |
| | B13 | | |
| | B24 | | |
| | C2 | | |
| | C4 | | |
| | C23 | | |
| | C25 | | |
| | D3 | | |
| | D5 | | |
| | D22 | | |
| | D24 | | |
| | E4 | | |
| | E6 | | |
| | E9 | | |
| | E18 | | |
| | E21 | | |
| | E23 | | |
| | F5 | | |
| | F8 | | |
| | F10 | | |
| | F11 | | |
| | F13 | | |
| | F14 | | |
| | F16 | | |
| | F17 | | |
| | F19 | | |
| | F22 | | |
| | G9 | | |
| G12 | | | |
| G15 | | | |
| G18 | | | |
| H1 | | | |
| H6 | | | |
| H21 | | | |
| H26 | | | |
| J5 | | | |
| J7 | | | |

† I = Input, O = Output, Z = High impedance, S = Supply voltage, GND = Ground

ADVANCE INFORMATION



TMS320C6414, TMS320C6415, TMS320C6416 FIXED-POINT DIGITAL SIGNAL PROCESSORS

SPRS146L – FEBRUARY 2001 – REVISED JULY 2004

Terminal Functions (Continued)

| SIGNAL NAME | NO. | TYPE† | DESCRIPTION |
|--------------------------------|-----|-------|-------------|
| GROUND PINS (CONTINUED) | | | |
| V _{SS} | J20 | GND | Ground pins |
| | J22 | | |
| | K21 | | |
| | L6 | | |
| | L21 | | |
| | M7 | | |
| | M20 | | |
| | N6 | | |
| | N21 | | |
| | N25 | | |
| | P2 | | |
| | P6 | | |
| | P21 | | |
| | R7 | | |
| | R20 | | |
| | T6 | | |
| | T21 | | |
| | U6 | | |
| | U21 | | |
| | V5 | | |
| | V7 | | |
| | V20 | | |
| | V22 | | |
| | W1 | | |
| | W6 | | |
| | W21 | | |
| | W26 | | |
| | Y9 | | |
| | Y12 | | |
| | Y15 | | |
| Y18 | | | |
| AA5 | | | |
| AA8 | | | |
| AA10 | | | |
| AA11 | | | |
| AA13 | | | |
| AA14 | | | |
| AA16 | | | |
| AA17 | | | |

† I = Input, O = Output, Z = High impedance, S = Supply voltage, GND = Ground

ADVANCE INFORMATION



TMS320C6414, TMS320C6415, TMS320C6416 FIXED-POINT DIGITAL SIGNAL PROCESSORS

SPRS146L – FEBRUARY 2001 – REVISED JULY 2004

Terminal Functions (Continued)

| SIGNAL NAME | | TYPET | DESCRIPTION |
|-------------------------|------|-------|-------------|
| GROUND PINS (CONTINUED) | | | |
| VSS | AA19 | GND | Ground pins |
| | AA22 | | |
| | AB4 | | |
| | AB6 | | |
| | AB9 | | |
| | AB18 | | |
| | AB21 | | |
| | AB23 | | |
| | AC3 | | |
| | AC5 | | |
| | AC22 | | |
| | AC24 | | |
| | AD2 | | |
| | AD4 | | |
| | AD23 | | |
| | AD25 | | |
| | AE3 | | |
| | AE14 | | |
| AE24 | | | |
| AF8 | | | |
| AF19 | | | |

† I = Input, O = Output, Z = High impedance, S = Supply voltage, GND = Ground

ADVANCE INFORMATION



development support

TI offers an extensive line of development tools for the TMS320C6000™ DSP platform, including tools to evaluate the performance of the processors, generate code, develop algorithm implementations, and fully integrate and debug software and hardware modules.

The following products support development of C6000™ DSP-based applications:

Software Development Tools:

Code Composer Studio™ Integrated Development Environment (IDE): including Editor
C/C++/Assembly Code Generation, and Debug plus additional development tools

Scalable, Real-Time Foundation Software (DSP/BIOS™), which provides the basic run-time target software needed to support any DSP application.

Hardware Development Tools:

Extended Development System (XDS™) Emulator (supports C6000™ DSP multiprocessor system debug)
EVM (Evaluation Module)

For a complete listing of development-support tools for the TMS320C6000™ DSP platform, visit the Texas Instruments web site on the Worldwide Web at <http://www.ti.com> uniform resource locator (URL). For information on pricing and availability, contact the nearest TI field sales office or authorized distributor.

Code Composer Studio, DSP/BIOS, and XDS are trademarks of Texas Instruments.



TMS320C6414, TMS320C6415, TMS320C6416 FIXED-POINT DIGITAL SIGNAL PROCESSORS

SPRS146L – FEBRUARY 2001 – REVISED JULY 2004

device support

device and development-support tool nomenclature

To designate the stages in the product development cycle, TI assigns prefixes to the part numbers of all TMS320™ DSP devices and support tools. Each TMS320™ DSP commercial family member has one of three prefixes: TMX, TMP, or TMS. Texas Instruments recommends two of three possible prefix designators for its support tools: TMDX and TMDS. These prefixes represent evolutionary stages of product development from engineering prototypes (TMX/TMDX) through fully qualified production devices/tools (TMS/TMDS).

Device development evolutionary flow:

- TMX** Experimental device that is not necessarily representative of the final device's electrical specifications
- TMP** Final silicon die that conforms to the device's electrical specifications but has not completed quality and reliability verification
- TMS** Fully qualified production device

Support tool development evolutionary flow:

- TMDX** Development-support product that has not yet completed Texas Instruments internal qualification testing.
- TMDS** Fully qualified development-support product

TMX and TMP devices and TMDX development-support tools are shipped against the following disclaimer:

“Developmental product is intended for internal evaluation purposes.”

TMS devices and TMDS development-support tools have been characterized fully, and the quality and reliability of the device have been demonstrated fully. TI's standard warranty applies.

Predictions show that prototype devices (TMX or TMP) have a greater failure rate than the standard production devices. Texas Instruments recommends that these devices not be used in any production system because their expected end-use failure rate still is undefined. Only qualified production devices are to be used.

TI device nomenclature also includes a suffix with the device family name. This suffix indicates the package type (for example, GLZ), the temperature range (for example, blank is the default commercial temperature range), and the device speed range in megahertz (for example, -6E3 is 600-MHz CPU, 133-MHz EMIFA). Figure 5 provides a legend for reading the complete device name for any TMS320C64x™ DSP generation member.

The ZLZ package, like the GLZ package, is a 532-pin plastic BGA *only* with lead-free balls. The ZLZ package type is available upon request. For device part numbers and further ordering information for TMS320C6414/C6415/C6416 in the GLZ and ZLZ package types, see the TI website (<http://www.ti.com>) or contact your TI sales representative.

TMS320 is a trademark of Texas Instruments.



TMS320C6414, TMS320C6415, TMS320C6416 FIXED-POINT DIGITAL SIGNAL PROCESSORS

SPRS146L – FEBRUARY 2001 – REVISED JULY 2004

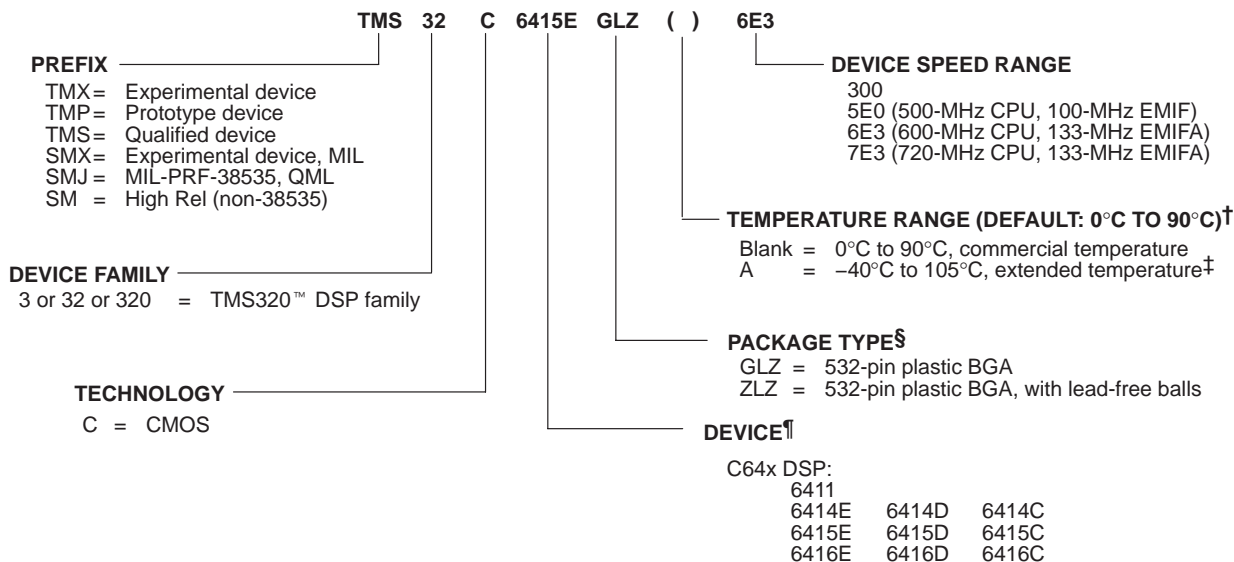

† See the Recommended Operating Conditions section of this data sheet for more details.

‡ The extended temperature "A version" devices may have different operating conditions than the commercial temperature devices.

See the Recommended Operating Conditions section of this data sheet for more details.

§ BGA= Ball Grid Array

¶ For the actual device part numbers (P/Ns) and ordering information, see the TI website (www.ti.com).

Figure 5. TMS320C64x™ DSP Device Nomenclature (Including the C6414, C6415, and C6416 Devices)

For additional information, see the *TMS320C6414*, *TMS320C6415*, and *TMS320C6416 Digital Signal Processors Silicon Errata* (literature number SPRZ011)

TMS320C6414, TMS320C6415, TMS320C6416 FIXED-POINT DIGITAL SIGNAL PROCESSORS

SPRS146L – FEBRUARY 2001 – REVISED JULY 2004

documentation support

Extensive documentation supports all TMS320™ DSP family generations of devices from product announcement through applications development. The types of documentation available include: data sheets, such as this document, with design specifications; complete user's reference guides for all devices and tools; technical briefs; development-support tools; on-line help; and hardware and software applications. The following is a brief, descriptive list of support documentation specific to the C6000™ DSP devices:

The *TMS320C6000 CPU and Instruction Set Reference Guide* (literature number SPRU189) describes the C6000™ DSP CPU (core) architecture, instruction set, pipeline, and associated interrupts.

The *TMS320C6000 DSP Peripherals Overview Reference Guide* (literature number SPRU190) provides an overview and briefly describes the functionality of the peripherals available on the C6000™ DSP platform of devices. This document also includes a table listing the peripherals available on the C6000 devices along with literature numbers and hyperlinks to the associated peripheral documents.

The *TMS320C64x Technical Overview* (literature number SPRU395) gives an introduction to the C64x™ digital signal processor, and discusses the application areas that are enhanced by the C64x™ DSP Velocity™ VLIW architecture.

The *TMS320C6414, TMS320C6415, and TMS320C6416 Digital Signal Processors Silicon Errata* (literature number SPRZ011) describes the known exceptions to the functional specifications for the TMS320C6414, TMS320C6415, and TMS320C6416 devices.

The *TMS320C6414/15/16 Power Consumption Summary* application report (literature number SPRA811) discusses the power consumption for user applications with the TMS320C6414, TMS320C6415, and TMS320C6416 DSP devices.

The *Using IBIS Models for Timing Analysis* application report (literature number SPRA839) describes how to properly use IBIS models to attain accurate timing analysis for a given system.

The *How To Begin Development Today With the TMS320C6414, TMS320C6415, and TMS320C6416 DSPs* application report (literature number SPRA718) describes in more detail the compatibility and similarities/differences among the C6414, C6415, C6416, and C6211 devices.

The tools support documentation is electronically available within the Code Composer Studio™ Integrated Development Environment (IDE). For a complete listing of C6000™ DSP latest documentation, visit the Texas Instruments web site on the Worldwide Web at <http://www.ti.com> uniform resource locator (URL).

clock PLL

Most of the internal C64x™ DSP clocks are generated from a single source through the CLKIN pin. This source clock either drives the PLL, which multiplies the source clock frequency to generate the internal CPU clock, or bypasses the PLL to become the internal CPU clock.

To use the PLL to generate the CPU clock, the external PLL filter circuit must be properly designed. Figure 6 shows the external PLL circuitry for either x1 (PLL bypass) or other PLL multiply modes.

To minimize the clock jitter, a single clean power supply should power both the C64x™ DSP device and the external clock oscillator circuit. The minimum CLKIN rise and fall times should also be observed. For the input clock timing requirements, see the *input and output clocks* electricals section.

Rise/fall times, duty cycles (high/low pulse durations), and the load capacitance of the external clock source must meet the DSP requirements in this data sheet (see the *electrical characteristics over recommended ranges of supply voltage and operating case temperature* table and the *input and output clocks* electricals section). Table 30 lists some examples of compatible CLKIN external clock sources:

Table 30. Compatible CLKIN External Clock Sources

| COMPATIBLE PARTS FOR EXTERNAL CLOCK SOURCES (CLKIN) | PART NUMBER | MANUFACTURER |
|---|---------------------------|----------------------------|
| Oscillators | JITO-2 | Fox Electronix |
| | STA series, ST4100 series | SaRonix Corporation |
| | SG-636 | Epson America |
| | 342 | Corning Frequency Control |
| PLL | ICS525-02 | Integrated Circuit Systems |
| Spread Spectrum Clock Generator | MK1714 | |

TMS320C6414, TMS320C6415, TMS320C6416 FIXED-POINT DIGITAL SIGNAL PROCESSORS

SPRS146L – FEBRUARY 2001 – REVISED JULY 2004

clock PLL (continued)

ADVANCE INFORMATION

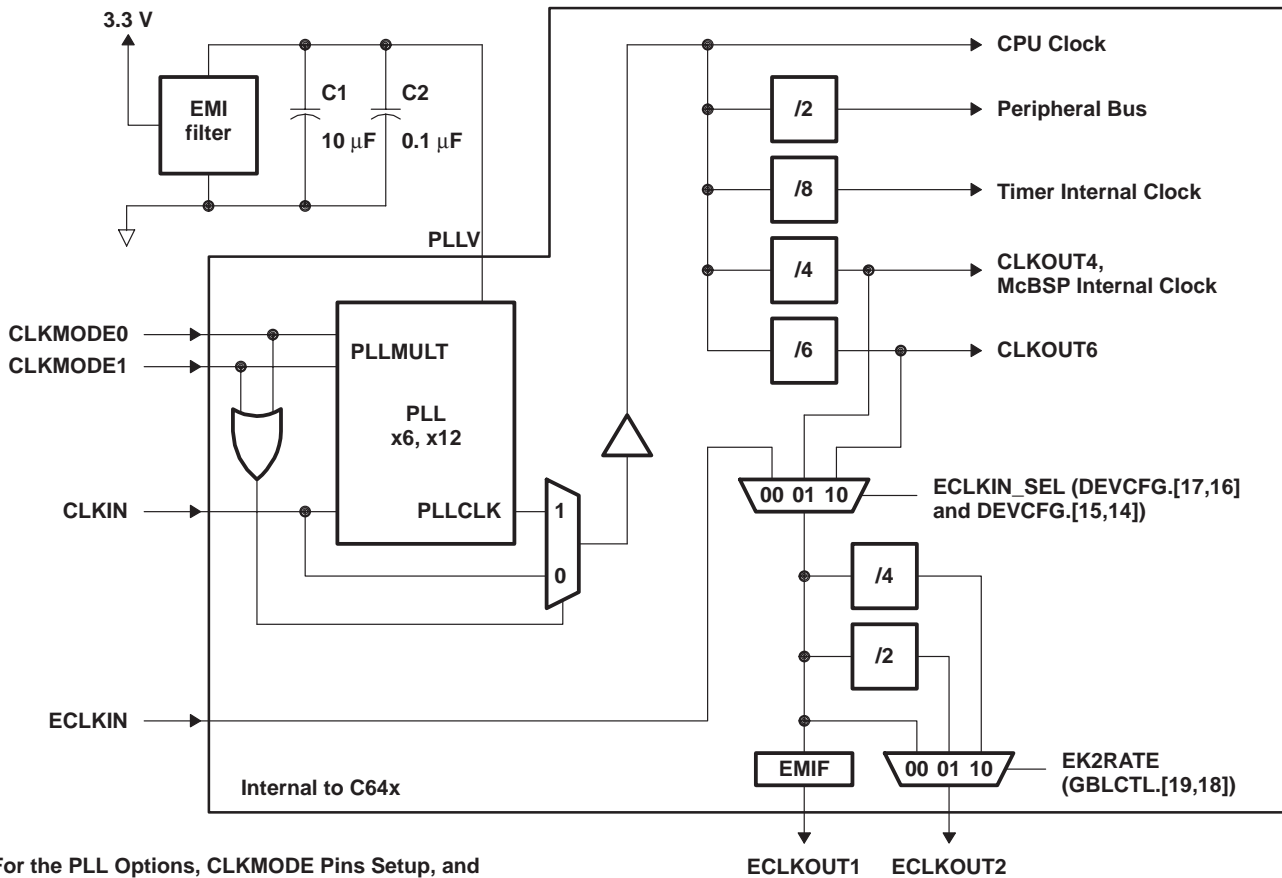

(For the PLL Options, CLKMODE Pins Setup, and PLL Clock Frequency Ranges, see Table 31.)

- NOTES:
- A. Place all PLL external components (C1, C2, and the EMI Filter) as close to the C6000™ DSP device as possible. For the best performance, TI recommends that all the PLL external components be on a single side of the board without jumpers, switches, or components other than the ones shown.
 - B. For reduced PLL jitter, maximize the spacing between switching signals and the PLL external components (C1, C2, and the EMI Filter).
 - C. The 3.3-V supply for the EMI filter must be from the same 3.3-V power plane supplying the I/O voltage, DV_{DD}.
 - D. EMI filter manufacturer TDK part number ACF451832-333, -223, -153, -103. Panasonic part number EXCCET103U.

Figure 6. External PLL Circuitry for Either PLL Multiply Modes or x1 (Bypass) Mode

clock PLL (continued)

Table 31. TMS320C64x PLL Multiply Factor Options, Clock Frequency Ranges, and Typical Lock Time†‡

| GLZ and ZLZ PACKAGE – 23 x 23 mm BGA | | | | | | | |
|--------------------------------------|----------|--------------------------------------|-------------------------|---------------------------------------|------------------------|------------------------|-------------------------------------|
| CLKMODE1 | CLKMODE0 | CLKMODE (PLL MULTIPLY FACTORS) | CLKIN RANGE (MHz) | CPU CLOCK FREQUENCY RANGE (MHz) | CLKOUT4 RANGE (MHz) | CLKOUT6 RANGE (MHz) | TYPICAL LOCK TIME (μ s)§ |
| 0 | 0 | Bypass (x1) | 30–75.75 | 30–75.75 | 7.5–18.9 | 5–12.6 | N/A |
| 0 | 1 | x6 | 30–75.75 | 180–454.5 | 45–113.6 | 30–75.75 | 75 |
| 1 | 0 | x12 | 30–60.6 | 360–727.2 | 90–181.8 | 60–121.2 | |
| 1 | 1 | Reserved | – | – | – | – | – |

† These clock frequency range values are applicable to a C64x–6E3 speed device. For –5E0 and –7E3 device speed values, see the CLKIN timing requirements table for the specific device speed.

‡ Use external pullup resistors on the CLKMODE pins (CLKMODE1 and CLKMODE0) to set the C64x device to one of the valid PLL multiply clock modes (x6 or x12). With internal pulldown resistors on the CLKMODE pins (CLKMODE1, CLKMODE0), the default clock mode is x1 (bypass).

§ Under some operating conditions, the maximum PLL lock time may vary by as much as 150% from the specified typical value. For example, if the typical lock time is specified as 100 μ s, the maximum value may be as long as 250 μ s.

TMS320C6414, TMS320C6415, TMS320C6416 FIXED-POINT DIGITAL SIGNAL PROCESSORS

SPRS146L – FEBRUARY 2001 – REVISED JULY 2004

general-purpose input/output (GPIO)

To use the GP[15:0] software-configurable GPIO pins, the GPxEN bits in the GP Enable (GPEN) Register and the GPxDIR bits in the GP Direction (GPDIR) Register must be properly configured.

GPxEN = 1 GP[x] pin is enabled

GPxDIR = 0 GP[x] pin is an input

GPxDIR = 1 GP[x] pin is an output

where “x” represents one of the 15 through 0 GPIO pins

Figure 7 shows the GPIO enable bits in the GPEN register for the C6414/C6415/C6416 device. To use any of the GPx pins as general-purpose input/output functions, the corresponding GPxEN bit must be set to “1” (enabled). Default values are device-specific, so refer to Figure 7 for the C6414/15/16 default configuration.

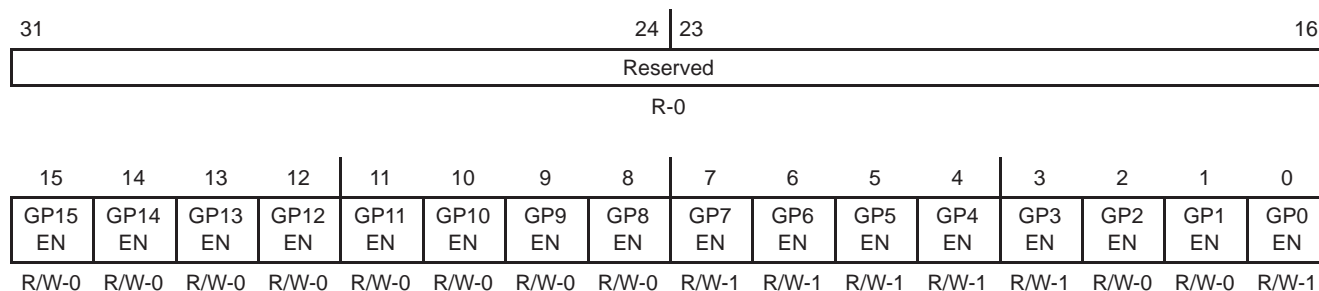

Legend: R/W = Readable/Writeable; -n = value after reset, -x = undefined value after reset

Figure 7. GPIO Enable Register (GPEN) [Hex Address: 01B0 0000]

Figure 8 shows the GPIO direction bits in the GPDIR register. This register determines if a given GPIO pin is an input or an output providing the corresponding GPxEN bit is enabled (set to “1”) in the GPEN register. By default, all the GPIO pins are configured as input pins.

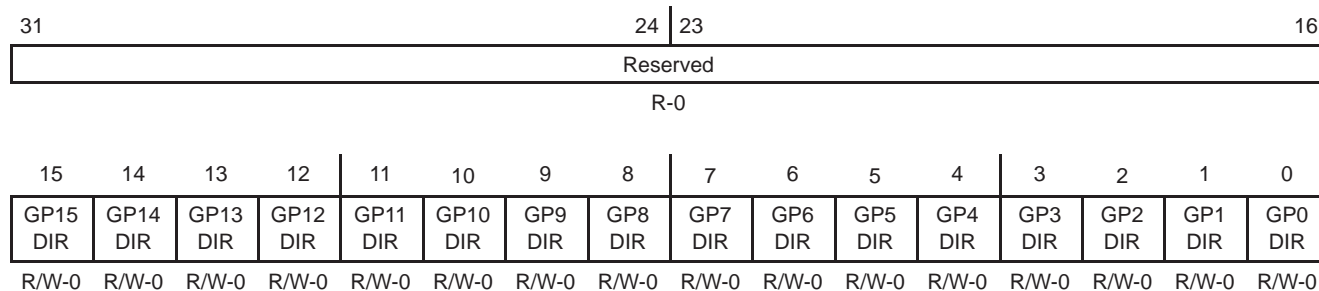

Legend: R/W = Readable/Writeable; -n = value after reset, -x = undefined value after reset

Figure 8. GPIO Direction Register (GPDIR) [Hex Address: 01B0 0004]

For more detailed information on general-purpose inputs/outputs (GPIOs), see the *TMS320C6000 DSP General-Purpose Input/Output (GPIO) Reference Guide* (literature number SPRU584).

power-down mode logic

Figure 9 shows the power-down mode logic on the C6414/C6415/C6416.

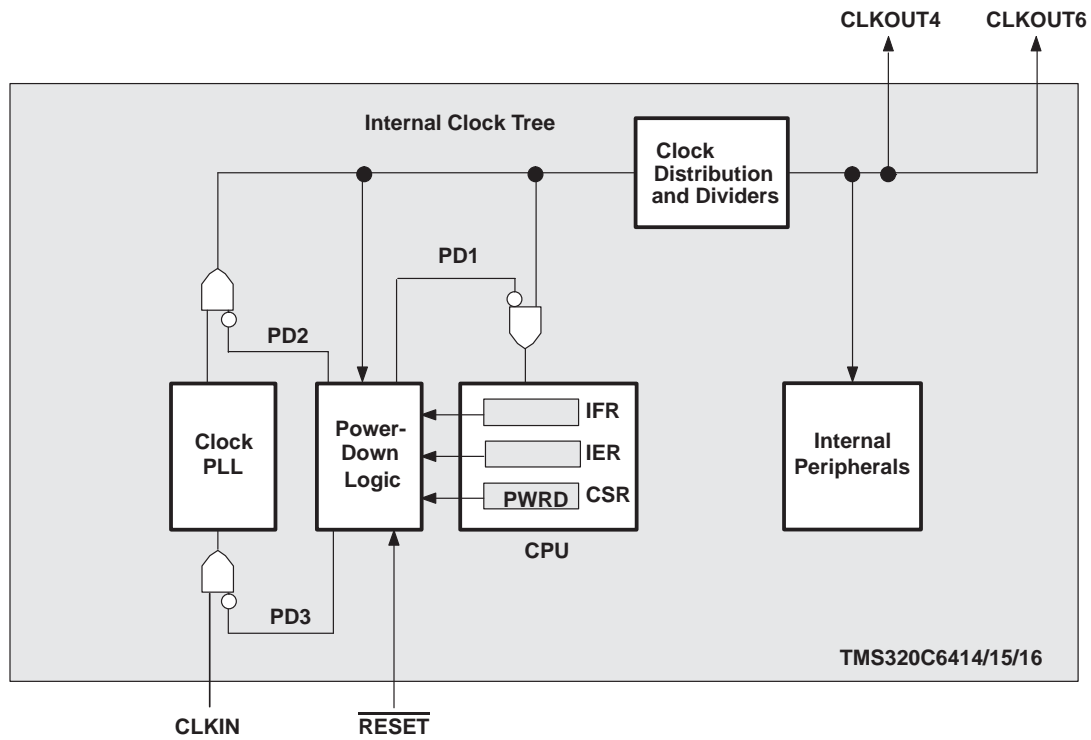

† External input clocks, with the exception of CLKIN, are *not* gated by the power-down mode logic.

Figure 9. Power-Down Mode Logic†

triggering, wake-up, and effects

The power-down modes and their wake-up methods are programmed by setting the PWRD field (bits 15–10) of the control status register (CSR). The PWRD field of the CSR is shown in Figure 10 and described in Table 32. When writing to the CSR, all bits of the PWRD field should be set at the same time. Logic 0 should be used when writing to the reserved bit (bit 15) of the PWRD field. The CSR is discussed in detail in the *TMS320C6000 CPU and Instruction Set Reference Guide* (literature number SPRU189).

ADVANCE INFORMATION

TMS320C6414, TMS320C6415, TMS320C6416 FIXED-POINT DIGITAL SIGNAL PROCESSORS

SPRS146L – FEBRUARY 2001 – REVISED JULY 2004

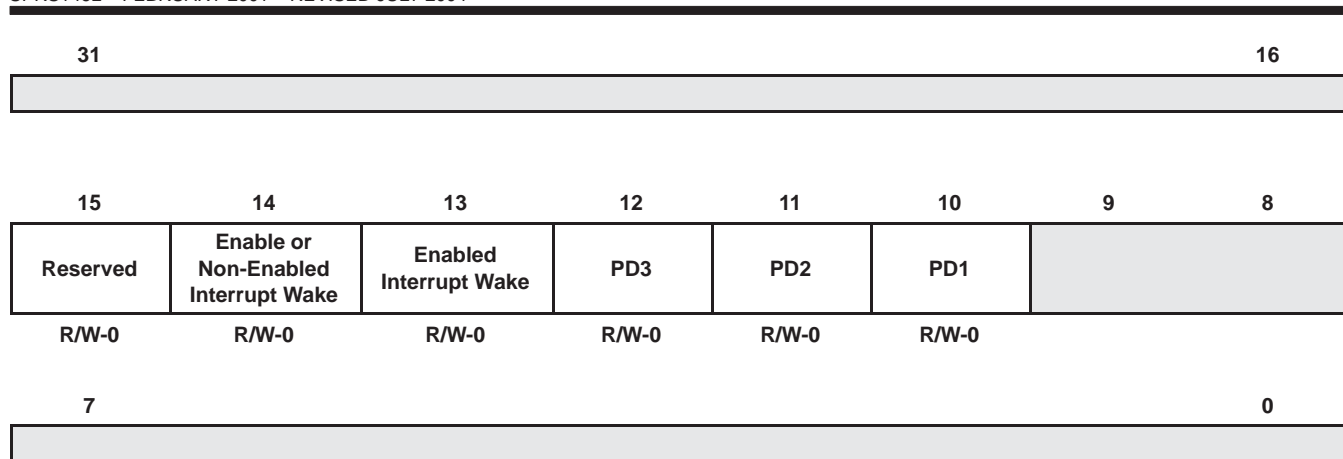

Legend: R/W-x = Read/write reset value

NOTE: The shadowed bits are not part of the power-down logic discussion and therefore are not covered here. For information on these other bit fields in the CSR register, see the *TMS320C6000 CPU and Instruction Set Reference Guide* (literature number SPRU189).

Figure 10. PWRD Field of the CSR Register

A delay of up to nine cycles may occur after the instruction that sets the PWRD bits in the CSR before the PD mode takes effect. As best practice, NOPs should be padded after the PWRD bits are set in the CSR to account for this delay.

If PD1 mode is terminated by a non-enabled interrupt, the program execution returns to the instruction where PD1 took effect. If PD1 mode is terminated by an enabled interrupt, the interrupt service routine will be executed first, then the program execution returns to the instruction where PD1 took effect. In the case with an enabled interrupt, the GIE bit in the CSR and the NMIE bit in the interrupt enable register (IER) must also be set in order for the interrupt service routine to execute; otherwise, execution returns to the instruction where PD1 took effect upon PD1 mode termination by an enabled interrupt.

PD2 and PD3 modes can only be aborted by device reset. Table 32 summarizes all the power-down modes.

ADVANCE INFORMATION



Table 32. Characteristics of the Power-Down Modes

| PRWD FIELD (BITS 15–10) | POWER-DOWN MODE | WAKE-UP METHOD | EFFECT ON CHIP'S OPERATION |
|-------------------------|-----------------|---|--|
| 000000 | No power-down | — | — |
| 001001 | PD1 | Wake by an enabled interrupt | CPU halted (except for the interrupt logic) Power-down mode blocks the internal clock inputs at the boundary of the CPU, preventing most of the CPU's logic from switching. During PD1, EDMA transactions can proceed between peripherals and internal memory. |
| 010001 | PD1 | Wake by an enabled or non-enabled interrupt | |
| 011010 | PD2† | Wake by a device reset | Output clock from PLL is halted, stopping the internal clock structure from switching and resulting in the entire chip being halted. All register and internal RAM contents are preserved. All functional I/O "freeze" in the last state when the PLL clock is turned off. |
| 011100 | PD3† | Wake by a device reset | Input clock to the PLL stops generating clocks. All register and internal RAM contents are preserved. All functional I/O "freeze" in the last state when the PLL clock is turned off. Following reset, the PLL needs time to re-lock, just as it does following power-up. Wake-up from PD3 takes longer than wake-up from PD2 because the PLL needs to be re-locked, just as it does following power-up. |
| All others | Reserved | — | — |

† When entering PD2 and PD3, all functional I/O remains in the previous state. However, for peripherals which are asynchronous in nature or peripherals with an external clock source, output signals may transition in response to stimulus on the inputs. Under these conditions, peripherals will not operate according to specifications.

C64x power-down mode with an emulator

If user power-down modes are programmed, and an emulator is attached, the modes will be masked to allow the emulator access to the system. This condition prevails until the emulator is reset or the cable is removed from the header. If power measurements are to be performed when in a power-down mode, the emulator cable should be removed.

When the DSP is in power-down mode PD2 or PD3, emulation logic will force any emulation execution command (such as Step or Run) to spin in IDLE. For this reason, PC writes (such as loading code) will fail. A DSP reset will be required to get the DSP out of PD2/PD3.

power-supply sequencing

TI DSPs do not require specific power sequencing between the core supply and the I/O supply. However, systems should be designed to ensure that neither supply is powered up for extended periods of time (>1 second) if the other supply is below the proper operating voltage.

power-supply design considerations

A dual-power supply with simultaneous sequencing can be used to eliminate the delay between core and I/O power up. A Schottky diode can also be used to tie the core rail to the I/O rail (see Figure 11).

TMS320C6414, TMS320C6415, TMS320C6416 FIXED-POINT DIGITAL SIGNAL PROCESSORS

SPRS146L – FEBRUARY 2001 – REVISED JULY 2004

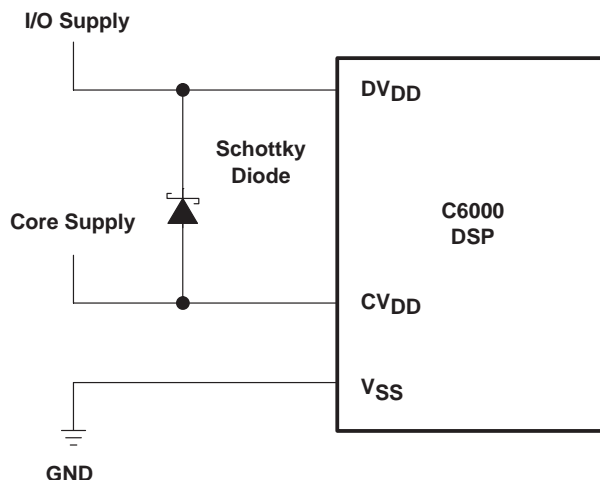

Figure 11. Schottky Diode Diagram

Core and I/O supply voltage regulators should be located close to the DSP (or DSP array) to minimize inductance and resistance in the power delivery path. Additionally, when designing for high-performance applications utilizing the C6000™ platform of DSPs, the PC board should include separate power planes for core, I/O, and ground, all bypassed with high-quality low-ESL/ESR capacitors.

power-supply decoupling

In order to properly decouple the supply planes from system noise, place as many capacitors (caps) as possible close to the DSP. Assuming 0603 caps, the user should be able to fit a total of 60 caps, 30 for the core supply and 30 for the I/O supply. These caps need to be close to the DSP power pins, no more than 1.25 cm maximum distance to be effective. Physically smaller caps, such as 0402, are better because of their lower parasitic inductance. Proper capacitance values are also important. Small bypass caps (near 560 pF) should be closest to the power pins. Medium bypass caps (220 nF or as large as can be obtained in a small package) should be next closest. TI recommends no less than 8 small and 8 medium caps per supply (32 total) be placed immediately next to the BGA vias, using the “interior” BGA space and at least the corners of the “exterior”.

Eight larger caps (4 for each supply) can be placed further away for bulk decoupling. Large bulk caps (on the order of 100 μ F) should be furthest away (but still as close as possible). No less than 4 large caps per supply (8 total) should be placed outside of the BGA.

Any cap selection needs to be evaluated from a yield/manufacturing point-of-view. As with the selection of any component, verification of capacitor availability over the product’s production lifetime should be considered.

ADVANCE INFORMATION

IEEE 1149.1 JTAG compatibility statement

The TMS320C6414/15/16 DSP requires that both $\overline{\text{TRST}}$ and $\overline{\text{RESET}}$ be asserted upon power up to be properly initialized. While $\overline{\text{RESET}}$ initializes the DSP core, $\overline{\text{TRST}}$ initializes the DSP's emulation logic. Both resets are required for proper operation.

Note: $\overline{\text{TRST}}$ is synchronous and **must** be clocked by TCLK ; otherwise, BSCAN may not respond as expected after $\overline{\text{TRST}}$ is asserted.

While both $\overline{\text{TRST}}$ and $\overline{\text{RESET}}$ need to be asserted upon power up, only $\overline{\text{RESET}}$ needs to be released for the DSP to boot properly. $\overline{\text{TRST}}$ may be asserted indefinitely for normal operation, keeping the JTAG port interface and DSP's emulation logic in the reset state. $\overline{\text{TRST}}$ only needs to be released when it is necessary to use a JTAG controller to debug the DSP or exercise the DSP's boundary scan functionality. $\overline{\text{RESET}}$ must be released in order for boundary-scan JTAG to read the variant field of IDCODE correctly. Other boundary-scan instructions work correctly independent of current state of $\overline{\text{RESET}}$.

For maximum reliability, the TMS320C6414/15/16 DSP includes an internal pulldown (IPD) on the $\overline{\text{TRST}}$ pin to ensure that $\overline{\text{TRST}}$ will always be asserted upon power up and the DSP's internal emulation logic will always be properly initialized. JTAG controllers from Texas Instruments actively drive $\overline{\text{TRST}}$ high. However, some third-party JTAG controllers may not drive $\overline{\text{TRST}}$ high but expect the use of a pullup resistor on $\overline{\text{TRST}}$. When using this type of JTAG controller, assert $\overline{\text{TRST}}$ to initialize the DSP after powerup and externally drive $\overline{\text{TRST}}$ high before attempting any emulation or boundary scan operations.

Following the release of $\overline{\text{RESET}}$, the low-to-high transition of $\overline{\text{TRST}}$ must occur to latch the state of EMU1 and EMU0 . The $\text{EMU}[1:0]$ pins configure the device for either Boundary Scan mode or Normal/Emulation mode. For more detailed information, see the terminal functions section of this data sheet.

Note: The DESIGN_WARNING section of the TMS320C6414/15/16 BSDL file contains information and constraints regarding proper device operation while in Boundary Scan Mode.

EMIF device speed

The rated EMIF speed, referring to both EMIFA and EMIFB , of these devices only applies to the SDRAM interface when in a system that meets the following requirements:

- 1 chip-enable (CE) space (maximum of 2 chips) of SDRAM connected to EMIF
- up to 1 CE space of buffers connected to EMIF
- EMIF trace lengths between 1 and 3 inches
- 166-MHz SDRAM for 133-MHz operation (applies only to EMIFA)
- 143-MHz SDRAM for 100-MHz operation

Other configurations may be possible, but timing analysis must be done to verify all AC timings are met. Verification of AC timings is mandatory when using configurations other than those specified above. TI recommends utilizing I/O buffer information specification (IBIS) to analyze all AC timings.

To properly use IBIS models to attain accurate timing analysis for a given system, see the *Using IBIS Models for Timing Analysis* application report (literature number SPRA839).

To maintain signal integrity, serial termination resistors should be inserted into all EMIF output signal lines (see the Terminal Functions table for the EMIF output signals).

TMS320C6414, TMS320C6415, TMS320C6416 FIXED-POINT DIGITAL SIGNAL PROCESSORS

SPRS146L – FEBRUARY 2001 – REVISED JULY 2004

bootmode

The C6414/15/16 device resets using the active-low signal $\overline{\text{RESET}}$. While $\overline{\text{RESET}}$ is low, the device is held in reset and is initialized to the prescribed reset state. Refer to reset timing for reset timing characteristics and states of device pins during reset. The release of $\overline{\text{RESET}}$ starts the processor running with the prescribed device configuration and boot mode.

The C6414/C6415/C6416 has three types of boot modes:

- Host boot

If host boot is selected, upon release of $\overline{\text{RESET}}$, the CPU is internally “stalled” while the remainder of the device is released. During this period, an external host can initialize the CPU’s memory space as necessary through the host interface, including internal configuration registers, such as those that control the EMIF or other peripherals. For the C6414 device, the HPI peripheral is used for host boot. For the C6415/C6416 device, the HPI peripheral is used for host boot if $\text{PCI_EN} = 0$, and the PCI peripheral is used for host boot if $\text{PCI_EN} = 1$. Once the host is finished with all necessary initialization, it must set the DSPINT bit in the HPIC register to complete the boot process. This transition causes the boot configuration logic to bring the CPU out of the “stalled” state. The CPU then begins execution from address 0. The DSPINT condition is not latched by the CPU, because it occurs while the CPU is still internally “stalled”. Also, DSPINT brings the CPU out of the “stalled” state only if the host boot process is selected. All memory may be written to and read by the host. This allows for the host to verify what it sends to the DSP if required. After the CPU is out of the “stalled” state, the CPU needs to clear the DSPINT, otherwise, no more DSPINTs can be received.

- EMIF boot (using default ROM timings)

Upon the release of $\overline{\text{RESET}}$, the 1K-Byte ROM code located in the beginning of $\overline{\text{CE1}}$ is copied to address 0 by the EDMA using the default ROM timings, while the CPU is internally “stalled”. The data should be stored in the endian format that the system is using. In this case, the EMIF automatically assembles consecutive 8-bit bytes to form the 32-bit instruction words to be copied. The transfer is automatically done by the EDMA as a single-frame block transfer from the ROM to address 0. After completion of the block transfer, the CPU is released from the “stalled” state and starts running from address 0.

- No boot

With no boot, the CPU begins direct execution from the memory located at address 0. Note: operation is undefined if invalid code is located at address 0.

reset

A hardware reset ($\overline{\text{RESET}}$) is required to place the DSP into a known good state out of power-up. The $\overline{\text{RESET}}$ signal can be asserted (pulled low) prior to ramping the core and I/O voltages or after the core and I/O voltages have reached their proper operating conditions. As a best practice, reset should be held low during power-up. Prior to deasserting $\overline{\text{RESET}}$ (low-to-high transition), the core and I/O voltages should be at their proper operating conditions and CLKIN should also be running at the correct frequency.

TMS320C6414, TMS320C6415, TMS320C6416 FIXED-POINT DIGITAL SIGNAL PROCESSORS

SPRS146L – FEBRUARY 2001 – REVISED JULY 2004

absolute maximum ratings over operating case temperature range (unless otherwise noted)[†]

| | | |
|--|--|-----------------------------|
| Supply voltage ranges: | CV_{DD} (see Note 1) | -0.3 V to 1.8 V |
| | DV_{DD} (see Note 1) | -0.3 V to 4 V |
| Input voltage ranges: | (except PCI), V_I | -0.3 V to 4 V |
| | (PCI), V_{IP} [C6415 and C6416 only] | -0.5 V to $DV_{DD} + 0.5$ V |
| Output voltage ranges: | (except PCI), V_O | -0.3 V to 4 V |
| | (PCI), V_{OP} [C6415 and C6416 only] | -0.5 V to $DV_{DD} + 0.5$ V |
| Operating case temperature ranges, T_C : | (default) | 0°C to 90°C |
| | (A version) [A-5E0, A-6E3] | -40°C to 105°C |
| Storage temperature range, T_{stg} | | -65°C to 150°C |

[†] Stresses beyond those listed under “absolute maximum ratings” may cause permanent damage to the device. These are stress ratings only, and functional operation of the device at these or any other conditions beyond those indicated under “recommended operating conditions” is not implied. Exposure to absolute-maximum-rated conditions for extended periods may affect device reliability.

NOTE 1: All voltage values are with respect to V_{SS} .

recommended operating conditions

| | | MIN | NOM | MAX | UNIT | |
|-----------|---|---|------|------------------|------|----|
| CV_{DD} | Supply voltage, Core (-5E0 device) [‡] | 1.14 | 1.2 | 1.26 | V | |
| CV_{DD} | Supply voltage, Core (A-5E0 device) [‡] | 1.19 | 1.25 | 1.31 | V | |
| CV_{DD} | Supply voltage, Core (-6E3, A-6E3, -7E3 devices) [‡] | 1.36 | 1.4 | 1.44 | V | |
| DV_{DD} | Supply voltage, I/O | 3.14 | 3.3 | 3.46 | V | |
| V_{SS} | Supply ground | 0 | 0 | 0 | V | |
| V_{IH} | High-level input voltage (except PCI) | 2 | | | V | |
| V_{IL} | Low-level input voltage (except PCI) | | | 0.8 | V | |
| V_{IP} | Input voltage (PCI) [C6415 and C6416 only] | -0.5 | | $DV_{DD} + 0.5$ | V | |
| V_{IHP} | High-level input voltage (PCI) [C6415 and C6416 only] | $0.5DV_{DD}$ | | $DV_{DD} + 0.5$ | V | |
| V_{ILP} | Low-level input voltage (PCI) [C6415 and C6416 only] | -0.5 | | $0.3DV_{DD}$ | V | |
| V_{OS} | Maximum voltage during overshoot/undershoot | -1.0 [§] | | 4.3 [§] | V | |
| T_C | Operating case temperature | Default | | 0 | 90 | °C |
| | | A version (C6414/15/16GLZA-5E0 and GLZA-6E3 only) | | -40 | 105 | °C |

[‡] Future variants of the C641x DSPs may operate at voltages ranging from 0.9 V to 1.4 V to provide a range of system power/performance options. TI highly recommends that users design-in a supply that can handle multiple voltages within this range (i.e., 1.2 V, 1.25 V, 1.3 V, 1.35 V, 1.4 V with $\pm 3\%$ tolerances) by implementing simple board changes such as reference resistor values or input pin configuration modifications. Examples of such supplies include the PT4660, PT5500, PT5520, PT6440, and PT6930 series from Power Trends, a subsidiary of Texas Instruments. Not incorporating a flexible supply may limit the system's ability to easily adapt to future versions of C641x devices.

[§] The absolute maximum ratings should *not* be exceeded for more than 30% of the cycle period.

ADVANCE INFORMATION



TMS320C6414, TMS320C6415, TMS320C6416 FIXED-POINT DIGITAL SIGNAL PROCESSORS

SPRS146L – FEBRUARY 2001 – REVISED JULY 2004

electrical characteristics over recommended ranges of supply voltage and operating case temperature (unless otherwise noted)

| PARAMETER | TEST CONDITION [†] | MIN | TYP | MAX | UNIT | | |
|------------------|--|---|-----|----------------------------------|------|-----|----|
| V _{OH} | High-level output voltage (except PCI) | DV _{DD} = MIN, I _{OH} = MAX | | 2.4 | V | | |
| V _{OHP} | High-level output voltage (PCI) [C6415/C6416 only] | I _{OHP} = -0.5 mA, DV _{DD} = 3.3 V | | 0.9DV _{DD} [¶] | V | | |
| V _{OL} | Low-level output voltage (except PCI) | DV _{DD} = MIN, I _{OL} = MAX | | 0.4 | V | | |
| V _{OLP} | Low-level output voltage (PCI) [C6415/C6416 only] | I _{OLP} = 1.5 mA, DV _{DD} = 3.3 V | | 0.1DV _{DD} [¶] | V | | |
| I _I | Input current (except PCI) | V _I = V _{SS} to DV _{DD} no opposing internal resistor | | ±10 | µA | | |
| | | V _I = V _{SS} to DV _{DD} opposing internal pullup resistor [‡] | | 50 | 100 | 150 | µA |
| | | V _I = V _{SS} to DV _{DD} opposing internal pulldown resistor [‡] | | -150 | -100 | -50 | µA |
| I _{IP} | Input leakage current (PCI) [C6415/C6416 only] [§] | 0 < V _{IP} < DV _{DD} = 3.3 V | | ±10 | µA | | |
| I _{OH} | High-level output current | EMIF, CLKOUT4, CLKOUT6, EMUx | | -16 | mA | | |
| | | Timer, UTOPIA, TDO, GPIO (Excluding GP[15:9, 2, 1]), McBSP | | -8 | mA | | |
| | | PCI/HPI | | -0.5 [¶] | mA | | |
| I _{OL} | Low-level output current | EMIF, CLKOUT4, CLKOUT6, EMUx | | 16 | mA | | |
| | | Timer, UTOPIA, TDO, GPIO (Excluding GP[15:9, 2, 1]), McBSP | | 8 | mA | | |
| | | PCI/HPI | | 1.5 [¶] | mA | | |
| I _{OZ} | Off-state output current | V _O = DV _{DD} or 0 V | | ±10 | µA | | |
| I _{CDD} | Core supply current [#] | CV _{DD} = 1.4 V, CPU clock = 720 MHz | | 900 | mA | | |
| | | CV _{DD} = 1.4 V, CPU clock = 600 MHz | | 750 | mA | | |
| | | CV _{DD} = 1.2 V, CPU clock = 500 MHz | | 550 | mA | | |
| I _{DDD} | I/O supply current [#] | DV _{DD} = 3.3 V, CPU clock = 600 MHz | | 125 | mA | | |
| C _i | Input capacitance | | | 10 | pF | | |
| C _o | Output capacitance | | | 10 | pF | | |

[†] For test conditions shown as MIN, MAX, or NOM, use the appropriate value specified in the recommended operating conditions table.

[‡] Applies only to pins with an internal pullup (IPU) or pulldown (IPD) resistor.

[§] PCI input leakage currents include Hi-Z output leakage for all bidirectional buffers with 3-state outputs.

[¶] These rated numbers are from the PCI specification version 2.3. The DC specification and AC specification are defined in Tables 4-3 and 4-4, respectively.

[#] Measured with average activity (50% high/50% low power). The actual current draw is highly application-dependent. For more details on core and I/O activity, refer to the *TMS320C6414/15/16 Power Consumption Summary* application report (literature number SPRA811).

recommended clock and control signal transition behavior

All clocks and control signals **must** transition between V_{IH} and V_{IL} (or between V_{IL} and V_{IH}) in a monotonic manner.

ADVANCE INFORMATION



PARAMETER MEASUREMENT INFORMATION

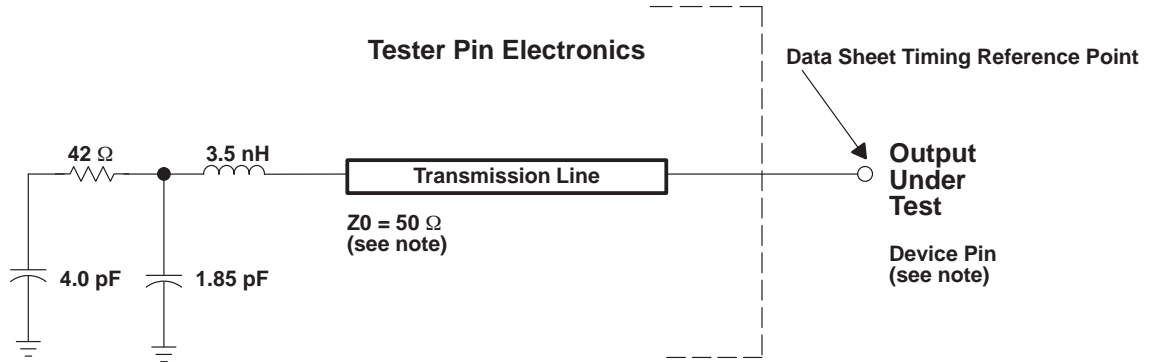

NOTE: The data sheet provides timing at the device pin. For output timing analysis, the tester pin electronics and its transmission line effects must be taken into account. A transmission line with a delay of 2 ns or longer can be used to produce the desired transmission line effect. The transmission line is intended as a load only. It is not necessary to add or subtract the transmission line delay (2 ns or longer) from the data sheet timings.

Input requirements in this data sheet are tested with an input slew rate of < 4 Volts per nanosecond (4 V/ns) at the device pin.

Figure 12. Test Load Circuit for AC Timing Measurements

The tester load circuit is for characterization and measurement of AC timing signals. This load does not indicate the maximum load the device is capable of driving.

signal transition levels

All input and output timing parameters are referenced to 1.5 V for both “0” and “1” logic levels.

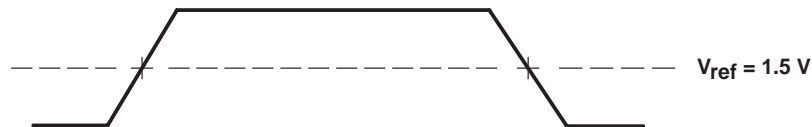

Figure 13. Input and Output Voltage Reference Levels for AC Timing Measurements

All rise and fall transition timing parameters are referenced to $V_{IL\ MAX}$ and $V_{IH\ MIN}$ for input clocks, $V_{OL\ MAX}$ and $V_{OH\ MIN}$ for output clocks, $V_{ILP\ MAX}$ and $V_{IHP\ MIN}$ for PCI input clocks, and $V_{OLP\ MAX}$ and $V_{OHP\ MIN}$ for PCI output clocks.

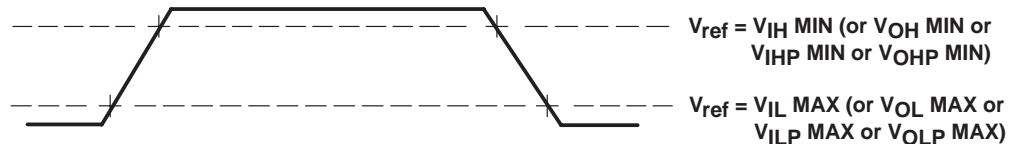

Figure 14. Rise and Fall Transition Time Voltage Reference Levels

signal transition rates

All timings are tested with an input edge rate of 4 Volts per nanosecond (4 V/ns).

PARAMETER MEASUREMENT INFORMATION (CONTINUED)

timing parameters and board routing analysis

The timing parameter values specified in this data sheet do *not* include delays by board routings. As a good board design practice, such delays must *always* be taken into account. Timing values may be adjusted by increasing/decreasing such delays. TI recommends utilizing the available I/O buffer information specification (IBIS) models to analyze the timing characteristics correctly. If needed, external logic hardware such as buffers may be used to compensate any timing differences.

For inputs, timing is most impacted by the round-trip propagation delay from the DSP to the external device and from the external device to the DSP. This round-trip delay tends to negatively impact the input setup time margin, but also tends to improve the input hold time margins (see Table 33 and Figure 15).

Figure 15 represents a general transfer between the DSP and an external device. The figure also represents board route delays and how they are perceived by the DSP and the external device.

Table 33. Board-Level Timings Example (see Figure 15)

| NO. | DESCRIPTION |
|-----|--|
| 1 | Clock route delay |
| 2 | Minimum DSP hold time |
| 3 | Minimum DSP setup time |
| 4 | External device hold time requirement |
| 5 | External device setup time requirement |
| 6 | Control signal route delay |
| 7 | External device hold time |
| 8 | External device access time |
| 9 | DSP hold time requirement |
| 10 | DSP setup time requirement |
| 11 | Data route delay |

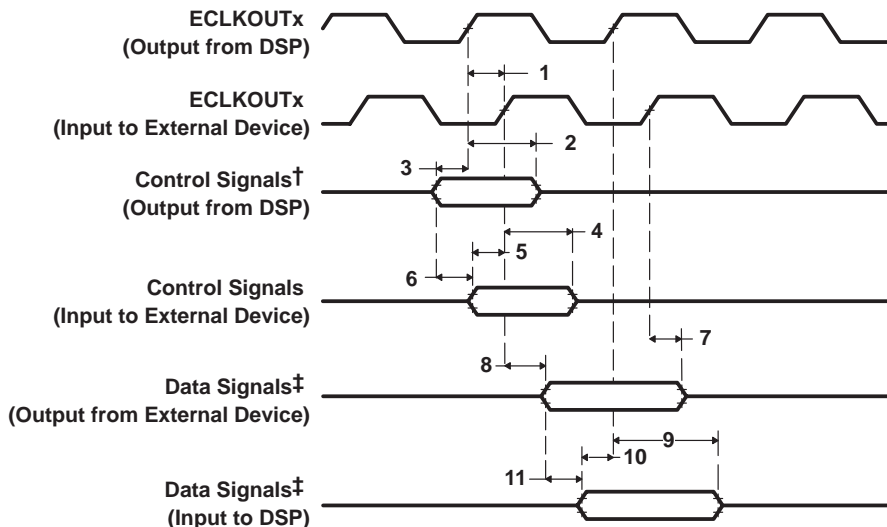

† Control signals include data for Writes.

‡ Data signals are generated during Reads from an external device.

Figure 15. Board-Level Input/Output Timings

ADVANCE INFORMATION

INPUT AND OUTPUT CLOCKS

timing requirements for CLKIN for -5E0 devices†‡§ (see Figure 16)

| NO. | | -5E0 A-5E0 | | | | | | UNIT |
|-----|---|---------------|------|-------------|------|-------------|------|------|
| | | PLL MODE x12 | | PLL MODE x6 | | x1 (BYPASS) | | |
| | | MIN | MAX | MIN | MAX | MIN | MAX | |
| 1 | $t_c(\text{CLKIN})$ Cycle time, CLKIN | 24 | 33.3 | 13.3 | 33.3 | 13.3 | 33.3 | ns |
| 2 | $t_w(\text{CLKINH})$ Pulse duration, CLKIN high | 0.4C | | 0.4C | | 0.45C | | ns |
| 3 | $t_w(\text{CLKINL})$ Pulse duration, CLKIN low | 0.4C | | 0.4C | | 0.45C | | ns |
| 4 | $t_t(\text{CLKIN})$ Transition time, CLKIN | 5 | | 5 | | 1 | | ns |
| 5 | $t_j(\text{CLKIN})$ Period jitter, CLKIN | 0.02C | | 0.02C | | 0.02C | | ns |

† The reference points for the rise and fall transitions are measured at V_{IL} MAX and V_{IH} MIN.

‡ For more details on the PLL multiplier factors (x6, x12), see the *Clock PLL* section of this data sheet.

§ C = CLKIN cycle time in ns. For example, when CLKIN frequency is 50 MHz, use C = 20 ns.

timing requirements for CLKIN for -6E3 devices†‡§ (see Figure 16)

| NO. | | -6E3, A-6E3 | | | | | | UNIT |
|-----|---|--------------|------|-------------|------|-------------|------|------|
| | | PLL MODE x12 | | PLL MODE x6 | | x1 (BYPASS) | | |
| | | MIN | MAX | MIN | MAX | MIN | MAX | |
| 1 | $t_c(\text{CLKIN})$ Cycle time, CLKIN | 20 | 33.3 | 13.3 | 33.3 | 13.3 | 33.3 | ns |
| 2 | $t_w(\text{CLKINH})$ Pulse duration, CLKIN high | 0.4C | | 0.4C | | 0.45C | | ns |
| 3 | $t_w(\text{CLKINL})$ Pulse duration, CLKIN low | 0.4C | | 0.4C | | 0.45C | | ns |
| 4 | $t_t(\text{CLKIN})$ Transition time, CLKIN | 5 | | 5 | | 1 | | ns |
| 5 | $t_j(\text{CLKIN})$ Period jitter, CLKIN | 0.02C | | 0.02C | | 0.02C | | ns |

† The reference points for the rise and fall transitions are measured at V_{IL} MAX and V_{IH} MIN.

‡ For more details on the PLL multiplier factors (x6, x12), see the *Clock PLL* section of this data sheet.

§ C = CLKIN cycle time in ns. For example, when CLKIN frequency is 50 MHz, use C = 20 ns.

timing requirements for CLKIN for -7E3 devices†‡§ (see Figure 16)

| NO. | | -7E3 | | | | | | UNIT |
|-----|---|--------------|------|-------------|------|-------------|------|------|
| | | PLL MODE x12 | | PLL MODE x6 | | x1 (BYPASS) | | |
| | | MIN | MAX | MIN | MAX | MIN | MAX | |
| 1 | $t_c(\text{CLKIN})$ Cycle time, CLKIN | 16.6 | 33.3 | 13.3 | 33.3 | 13.3 | 33.3 | ns |
| 2 | $t_w(\text{CLKINH})$ Pulse duration, CLKIN high | 0.4C | | 0.4C | | 0.45C | | ns |
| 3 | $t_w(\text{CLKINL})$ Pulse duration, CLKIN low | 0.4C | | 0.4C | | 0.45C | | ns |
| 4 | $t_t(\text{CLKIN})$ Transition time, CLKIN | 5 | | 5 | | 1 | | ns |
| 5 | $t_j(\text{CLKIN})$ Period jitter, CLKIN | 0.02C | | 0.02C | | 0.02C | | ns |

† The reference points for the rise and fall transitions are measured at V_{IL} MAX and V_{IH} MIN.

‡ For more details on the PLL multiplier factors (x6, x12), see the *Clock PLL* section of this data sheet.

§ C = CLKIN cycle time in ns. For example, when CLKIN frequency is 50 MHz, use C = 20 ns.

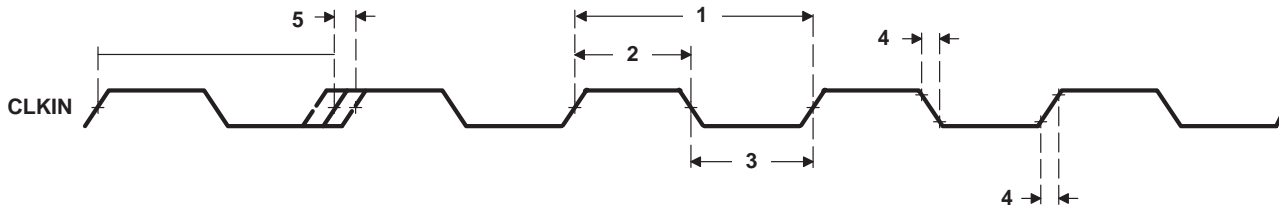

Figure 16. CLKIN Timing

ADVANCE INFORMATION

TMS320C6414, TMS320C6415, TMS320C6416 FIXED-POINT DIGITAL SIGNAL PROCESSORS

SPRS146L – FEBRUARY 2001 – REVISED JULY 2004

INPUT AND OUTPUT CLOCKS (CONTINUED)

switching characteristics over recommended operating conditions for CLKOUT4†‡§
(see Figure 17)

| NO. | PARAMETER | -5E0, A-5E0, -6E3, A-6E3, -7E3 | | UNIT |
|-----|---|--------------------------------------|------------|------|
| | | CLKMODE = x1, x6, x12 | | |
| | | MIN | MAX | |
| 1 | $t_{J(CKO4)}$ Period jitter, CLKOUT4 | 0 | ± 175 | ps |
| 2 | $t_{w(CKO4H)}$ Pulse duration, CLKOUT4 high | $2P - 0.7$ | $2P + 0.7$ | ns |
| 3 | $t_{w(CKO4L)}$ Pulse duration, CLKOUT4 low | $2P - 0.7$ | $2P + 0.7$ | ns |
| 4 | $t_t(CKO4)$ Transition time, CLKOUT4 | | 1 | ns |

† The reference points for the rise and fall transitions are measured at $V_{OL\ MAX}$ and $V_{OH\ MIN}$.

‡ PH is the high period of CLKIN in ns and PL is the low period of CLKIN in ns.

§ P = 1/CPU clock frequency in nanoseconds (ns)

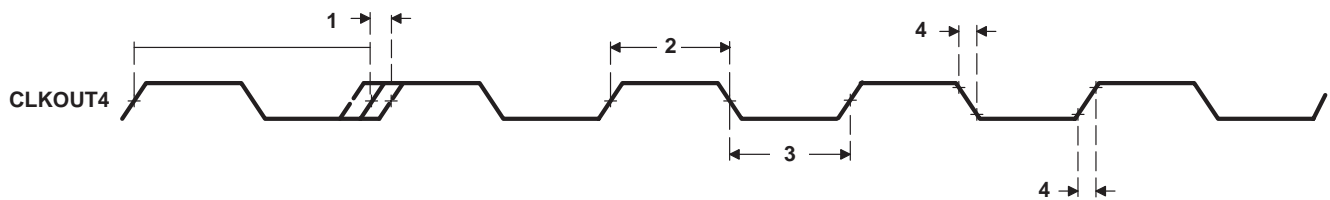

Figure 17. CLKOUT4 Timing

switching characteristics over recommended operating conditions for CLKOUT6†‡§
(see Figure 18)

| NO. | PARAMETER | -5E0, A-5E0, -6E3, A-6E3, -7E3 | | UNIT |
|-----|---|--------------------------------------|------------|------|
| | | CLKMODE = x1, x6, x12 | | |
| | | MIN | MAX | |
| 1 | $t_{J(CKO6)}$ Period jitter, CLKOUT6 | 0 | ± 175 | ps |
| 2 | $t_{w(CKO6H)}$ Pulse duration, CLKOUT6 high | $3P - 0.7$ | $3P + 0.7$ | ns |
| 3 | $t_{w(CKO6L)}$ Pulse duration, CLKOUT6 low | $3P - 0.7$ | $3P + 0.7$ | ns |
| 4 | $t_t(CKO6)$ Transition time, CLKOUT6 | | 1 | ns |

† The reference points for the rise and fall transitions are measured at $V_{OL\ MAX}$ and $V_{OH\ MIN}$.

‡ PH is the high period of CLKIN in ns and PL is the low period of CLKIN in ns.

§ P = 1/CPU clock frequency in nanoseconds (ns)

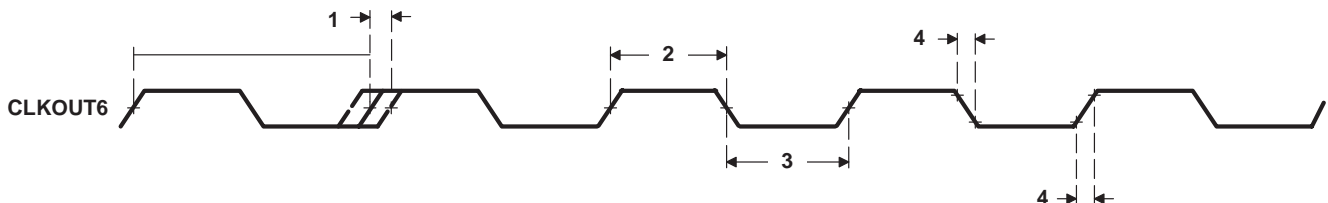

Figure 18. CLKOUT6 Timing

ADVANCE INFORMATION

INPUT AND OUTPUT CLOCKS (CONTINUED)

timing requirements for ECLKIN for EMIFA and EMIFB†‡§¶ (see Figure 19)

| NO. | | | -5E0, A-5E0, -6E3, A-6E3, -7E3 | | UNIT |
|-----|--------------------|-----------------------------|--------------------------------------|-------|------|
| | | | MIN | MAX | |
| 1 | $t_c(\text{EKI})$ | Cycle time, ECLKIN | 6 [#] | 16P | ns |
| 2 | $t_w(\text{EKIH})$ | Pulse duration, ECLKIN high | 2.7 | | ns |
| 3 | $t_w(\text{EKIL})$ | Pulse duration, ECLKIN low | 2.7 | | ns |
| 4 | $t_t(\text{EKI})$ | Transition time, ECLKIN | | 2 | ns |
| 5 | $t_j(\text{EKI})$ | Period jitter, ECLKIN | | 0.02E | ns |

† P = 1/CPU clock frequency in ns. For example, when running parts at 600 MHz, use P = 1.67 ns.

‡ The reference points for the rise and fall transitions are measured at V_{IL} MAX and V_{IH} MIN.

§ These C64x™ devices have two EMIFs (64-bit EMIFA and 16-bit EMIFB). All EMIFA signals are prefixed by an “A” and all EMIFB signals are prefixed by a “B”. Throughout the rest of this document, in generic EMIF areas of discussion, the prefix “A” or “B” may be omitted.

¶ E = the EMIF input clock (ECLKIN, CPU/4 clock, or CPU/6 clock) period in ns for EMIFA or EMIFB.

Minimum ECLKIN cycle times *must* be met, even when ECLKIN is generated by an internal clock source. Minimum ECLKIN times are based on internal logic speed; the maximum useable speed of the EMIF may be lower due to AC timing requirements. On the 7E3 and 6E3 devices, 133-MHz operation is achievable if the requirements of the EMIF Device Speed section are met. On the 5E0 devices, 100-MHz operation is achievable if the requirements of the EMIF Device Speed section are met.

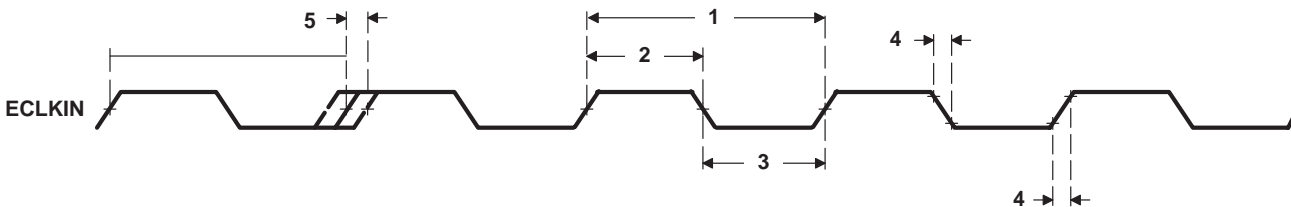

Figure 19. ECLKIN Timing for EMIFA and EMIFB

switching characteristics over recommended operating conditions for ECLKOUT1 for EMIFA and EMIFB modules§¶||* (see Figure 20)

| NO. | PARAMETER | -5E0, A-5E0, -6E3, A-6E3, -7E3 | | UNIT |
|-----|--------------------------|--------------------------------------|-------------------|------|
| | | MIN | MAX | |
| 1 | $t_j(\text{EKO1})$ | 0 | $\pm 175^\square$ | ps |
| 2 | $t_w(\text{EKO1H})$ | EH - 0.7 | EH + 0.7 | ns |
| 3 | $t_w(\text{EKO1L})$ | EL - 0.7 | EL + 0.7 | ns |
| 4 | $t_t(\text{EKO1})$ | | 1 | ns |
| 5 | $t_d(\text{EKIH-EKO1H})$ | 1 | 8 | ns |
| 6 | $t_d(\text{EKIL-EKO1L})$ | 1 | 8 | ns |

§ These C64x™ devices have two EMIFs (64-bit EMIFA and 16-bit EMIFB). All EMIFA signals are prefixed by an “A” and all EMIFB signals are prefixed by a “B”. Throughout the rest of this document, in generic EMIF areas of discussion, the prefix “A” or “B” may be omitted.

¶ E = the EMIF input clock (ECLKIN, CPU/4 clock, or CPU/6 clock) period in ns for EMIFA or EMIFB.

|| The reference points for the rise and fall transitions are measured at V_{OL} MAX and V_{OH} MIN.

* EH is the high period of E (EMIF input clock period) in ns and EL is the low period of E (EMIF input clock period) in ns for EMIFA or EMIFB.

□ This cycle-to-cycle jitter specification was measured with CPU/4 or CPU/6 as the source of the EMIF input clock.

INPUT AND OUTPUT CLOCKS (CONTINUED)

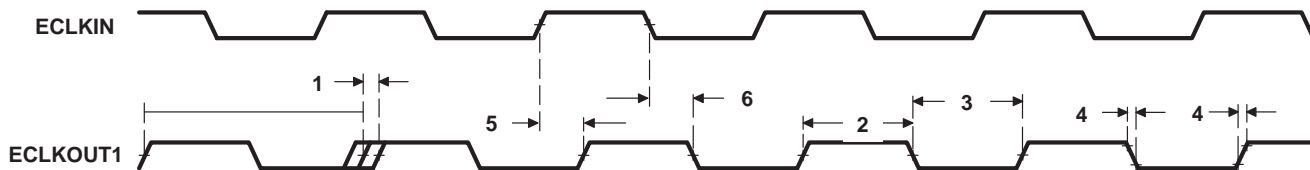

Figure 20. ECLKOUT1 Timing for EMIFA and EMIFB Modules

switching characteristics over recommended operating conditions for ECLKOUT2 for the EMIFA and EMIFB modules^{†‡§} (see Figure 21)

| NO. | PARAMETER | -5E0, A-5E0, -6E3, A-6E3, -7E3 | | UNIT |
|-----|--|--------------------------------------|----------------------------|------|
| | | MIN | MAX | |
| 1 | $t_{J(EKO2)}$ Period jitter, ECLKOUT2 | 0 | $\pm 175^{\dagger\dagger}$ | ps |
| 2 | $t_{w(EKO2H)}$ Pulse duration, ECLKOUT2 high | $0.5NE - 0.7$ | $0.5NE + 0.7$ | ns |
| 3 | $t_{w(EKO2L)}$ Pulse duration, ECLKOUT2 low | $0.5NE - 0.7$ | $0.5NE + 0.7$ | ns |
| 4 | $t_t(EKO2)$ Transition time, ECLKOUT2 | | 1 | ns |
| 5 | $t_d(EKIH-EKO2H)$ Delay time, ECLKIN high to ECLKOUT2 high | 1 | 8 | ns |
| 6 | $t_d(EKIH-EKO2L)$ Delay time, ECLKIN high to ECLKOUT2 low | 1 | 8 | ns |

[†] The reference points for the rise and fall transitions are measured at $V_{OL\ MAX}$ and $V_{OH\ MIN}$.
[‡] These C64x™ devices have two EMIFs (64-bit EMIFA and 16-bit EMIFB). All EMIFA signals are prefixed by an "A" and all EMIFB signals are prefixed by a "B". Throughout the rest of this document, in generic EMIF areas of discussion, the prefix "A" or "B" may be omitted.
[§] E = the EMIF input clock (ECLKIN, CPU/4 clock, or CPU/6 clock) period in ns for EMIFA or EMIFB.
 N = the EMIF input clock divider; N = 1, 2, or 4.
^{††} This cycle-to-cycle jitter specification was measured with CPU/4 or CPU/6 as the source of the EMIF input clock.

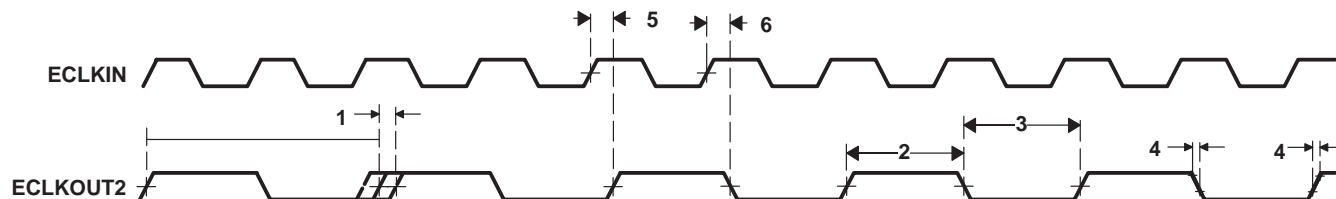

Figure 21. ECLKOUT2 Timing for the EMIFA and EMIFB Modules

ADVANCE INFORMATION

ASYNCHRONOUS MEMORY TIMING

timing requirements for asynchronous memory cycles for EMIFA module†‡§
(see Figure 22 and Figure 23)

| NO. | | | -5E0 -6E3 -7E3 | | A-5E0 A-6E3 | | UNIT |
|-----|------------------------------|---|----------------------|-----|----------------|-----|------|
| | | | MIN | MAX | MIN | MAX | |
| 3 | t _{su} (EDV-AREH) | Setup time, EDx valid before $\overline{\text{ARE}}$ high | 6.5 | | 6.5 | | ns |
| 4 | t _h (AREH-EDV) | Hold time, EDx valid after $\overline{\text{ARE}}$ high | 1 | | 1 | | ns |
| 6 | t _{su} (ARDY-EKO1H) | Setup time, ARDY valid before ECLKOUTx high | 3 | | 3 | | ns |
| 7 | t _h (EKO1H-ARDY) | Hold time, ARDY valid after ECLKOUTx high | Rev 1.1 and earlier | 1 | 1.5 | | ns |
| | | | Rev 2.0 | 1.3 | 1.5 | | ns |

† To ensure data setup time, simply program the strobe width wide enough. ARDY is internally synchronized. The ARDY signal is *only* recognized two cycles before the end of the programmed strobe time and while ARDY is low, the strobe time is extended cycle-by-cycle. When ARDY is recognized low, the end of the strobe time is two cycles after ARDY is recognized high. To use ARDY as an asynchronous input, the pulse width of the ARDY signal should be wide enough (e.g., pulse width = 2E) to ensure setup and hold time is met.

‡ RS = Read setup, RST = Read strobe, RH = Read hold, WS = Write setup, WST = Write strobe, WH = Write hold. These parameters are programmed via the EMIF CE space control registers.

§ These C64x™ devices have two EMIFs (EMIFA and EMIFB). All EMIFA signals are prefixed by an “A” and all EMIFB signals are prefixed by a “B”. Throughout the rest of this document, in generic EMIF areas of discussion, the prefix “A” or “B” may be omitted [e.g., the asynchronous memory access signals are shown as generic ($\overline{\text{AOE}}$, $\overline{\text{ARE}}$, and $\overline{\text{AWE}}$) instead of $\overline{\text{AAOE}}$, $\overline{\text{AARE}}$, and $\overline{\text{AAWE}}$ (for EMIFA) and $\overline{\text{BAOE}}$, $\overline{\text{BARE}}$, and $\overline{\text{BAWE}}$ (for EMIFB)].

switching characteristics over recommended operating conditions for asynchronous memory cycles for EMIFA module†§¶# (see Figure 22 and Figure 23)

| NO. | PARAMETER | -5E0, A-5E0, -6E3, A-6E3, -7E3 | | UNIT |
|-----|---|--------------------------------------|-----|------|
| | | MIN | MAX | |
| 1 | t _{osu} (SELV-AREL) Output setup time, select signals valid to $\overline{\text{ARE}}$ low | RS * E - 1.5 | | ns |
| 2 | t _{oh} (AREH-SELIV) Output hold time, $\overline{\text{ARE}}$ high to select signals invalid | RH * E - 1.9 | | ns |
| 5 | t _d (EKO1H-AREV) Delay time, ECLKOUTx high to $\overline{\text{ARE}}$ valid | 1 | 7 | ns |
| 8 | t _{osu} (SELV-AWEL) Output setup time, select signals valid to $\overline{\text{AWE}}$ low | WS * E - 1.7 | | ns |
| 9 | t _{oh} (AWEH-SELIV) Output hold time, $\overline{\text{AWE}}$ high to select signals invalid | WH * E - 1.8 | | ns |
| 10 | t _d (EKO1H-AWEV) Delay time, ECLKOUTx high to $\overline{\text{AWE}}$ valid | 1.3 | 7.1 | ns |

† RS = Read setup, RST = Read strobe, RH = Read hold, WS = Write setup, WST = Write strobe, WH = Write hold. These parameters are programmed via the EMIF CE space control registers.

§ These C64x™ devices have two EMIFs (EMIFA and EMIFB). All EMIFA signals are prefixed by an “A” and all EMIFB signals are prefixed by a “B”. Throughout the rest of this document, in generic EMIF areas of discussion, the prefix “A” or “B” may be omitted [e.g., the asynchronous memory access signals are shown as generic ($\overline{\text{AOE}}$, $\overline{\text{ARE}}$, and $\overline{\text{AWE}}$) instead of $\overline{\text{AAOE}}$, $\overline{\text{AARE}}$, and $\overline{\text{AAWE}}$ (for EMIFA) and $\overline{\text{BAOE}}$, $\overline{\text{BARE}}$, and $\overline{\text{BAWE}}$ (for EMIFB)].

¶ E = ECLKOUT1 period in ns for EMIFA or EMIFB

Select signals for EMIFA include: $\overline{\text{ACE}}_x$, $\overline{\text{ABE}}[7:0]$, $\overline{\text{AEA}}[22:3]$, $\overline{\text{AAOE}}$; and for EMIFA writes, include $\overline{\text{AED}}[63:0]$.
Select signals EMIFB include: $\overline{\text{BCE}}_x$, $\overline{\text{BBE}}[1:0]$, $\overline{\text{BEA}}[20:1]$, $\overline{\text{BAOE}}$; and for EMIFB writes, include $\overline{\text{BED}}[15:0]$.

ADVANCE INFORMATION

TMS320C6414, TMS320C6415, TMS320C6416 FIXED-POINT DIGITAL SIGNAL PROCESSORS

SPRS146L – FEBRUARY 2001 – REVISED JULY 2004

ASYNCHRONOUS MEMORY TIMING (CONTINUED)

timing requirements for asynchronous memory cycles for EMIFB module†‡§
(see Figure 22 and Figure 23)

| NO. | | | -5E0 -6E3 -7E3 | | A-5E0 A-6E3 | | UNIT |
|-----|------------------------------|---|----------------------|-----|----------------|-----|------|
| | | | MIN | MAX | MIN | MAX | |
| 3 | t _{su} (EDV-AREH) | Setup time, EDx valid before $\overline{\text{ARE}}$ high | 6.2 | | 6.2 | | ns |
| 4 | t _h (AREH-EDV) | Hold time, EDx valid after $\overline{\text{ARE}}$ high | 1 | | 1 | | ns |
| 6 | t _{su} (ARDY-EKO1H) | Setup time, ARDY valid before ECLKOUTx high | 3 | | 3 | | ns |
| 7 | t _h (EKO1H-ARDY) | Hold time, ARDY valid after ECLKOUTx high | Rev 1.1 and earlier | 1.2 | 1.7 | | ns |
| | | | Rev 2.0 | 1.3 | 1.7 | | ns |

† To ensure data setup time, simply program the strobe width wide enough. ARDY is internally synchronized. The ARDY signal is *only* recognized two cycles before the end of the programmed strobe time and while ARDY is low, the strobe time is extended cycle-by-cycle. When ARDY is recognized low, the end of the strobe time is two cycles after ARDY is recognized high. To use ARDY as an asynchronous input, the pulse width of the ARDY signal should be wide enough (e.g., pulse width = 2E) to ensure setup and hold time is met.

‡ RS = Read setup, RST = Read strobe, RH = Read hold, WS = Write setup, WST = Write strobe, WH = Write hold. These parameters are programmed via the EMIF CE space control registers.

§ These C64x™ devices have two EMIFs (EMIFA and EMIFB). All EMIFA signals are prefixed by an "A" and all EMIFB signals are prefixed by a "B". Throughout the rest of this document, in generic EMIF areas of discussion, the prefix "A" or "B" may be omitted [e.g., the asynchronous memory access signals are shown as generic ($\overline{\text{AOE}}$, $\overline{\text{ARE}}$, and $\overline{\text{AWE}}$) instead of $\overline{\text{AAOE}}$, $\overline{\text{AARE}}$, and $\overline{\text{AAWE}}$ (for EMIFA) and $\overline{\text{BAOE}}$, $\overline{\text{BARE}}$, and $\overline{\text{BAWE}}$ (for EMIFB)].

switching characteristics over recommended operating conditions for asynchronous memory cycles for EMIFB module†‡§¶# (see Figure 22 and Figure 23)

| NO. | PARAMETER | -5E0, A-5E0, -6E3, A-6E3, -7E3 | | UNIT |
|-----|---|--------------------------------------|-----|------|
| | | MIN | MAX | |
| 1 | t _{osu} (SELV-AREL) Output setup time, select signals valid to $\overline{\text{ARE}}$ low | RS * E - 1.6 | | ns |
| 2 | t _{oh} (AREH-SELIV) Output hold time, $\overline{\text{ARE}}$ high to select signals invalid | RH * E - 1.7 | | ns |
| 5 | t _d (EKO1H-AREV) Delay time, ECLKOUTx high to $\overline{\text{ARE}}$ valid | 0.8 | 6.6 | ns |
| 8 | t _{osu} (SELV-AWEL) Output setup time, select signals valid to $\overline{\text{AWE}}$ low | WS * E - 1.9 | | ns |
| 9 | t _{oh} (AWEH-SELIV) Output hold time, $\overline{\text{AWE}}$ high to select signals invalid | WH * E - 1.7 | | ns |
| 10 | t _d (EKO1H-AWEV) Delay time, ECLKOUTx high to $\overline{\text{AWE}}$ valid | 0.9 | 6.7 | ns |

† RS = Read setup, RST = Read strobe, RH = Read hold, WS = Write setup, WST = Write strobe, WH = Write hold. These parameters are programmed via the EMIF CE space control registers.

§ These C64x™ devices have two EMIFs (EMIFA and EMIFB). All EMIFA signals are prefixed by an "A" and all EMIFB signals are prefixed by a "B". Throughout the rest of this document, in generic EMIF areas of discussion, the prefix "A" or "B" may be omitted [e.g., the asynchronous memory access signals are shown as generic ($\overline{\text{AOE}}$, $\overline{\text{ARE}}$, and $\overline{\text{AWE}}$) instead of $\overline{\text{AAOE}}$, $\overline{\text{AARE}}$, and $\overline{\text{AAWE}}$ (for EMIFA) and $\overline{\text{BAOE}}$, $\overline{\text{BARE}}$, and $\overline{\text{BAWE}}$ (for EMIFB)].

¶ E = ECLKOUT1 period in ns for EMIFA or EMIFB

Select signals for EMIFA include: $\overline{\text{ACEx}}$, $\overline{\text{ABE}}[7:0]$, $\overline{\text{AEA}}[22:3]$, $\overline{\text{AAOE}}$; and for EMIFA writes, include $\overline{\text{AED}}[63:0]$.

Select signals EMIFB include: $\overline{\text{BCEx}}$, $\overline{\text{BBE}}[1:0]$, $\overline{\text{BEA}}[20:1]$, $\overline{\text{BAOE}}$; and for EMIFB writes, include $\overline{\text{BED}}[15:0]$.

ADVANCE INFORMATION



ASYNCHRONOUS MEMORY TIMING (CONTINUED)

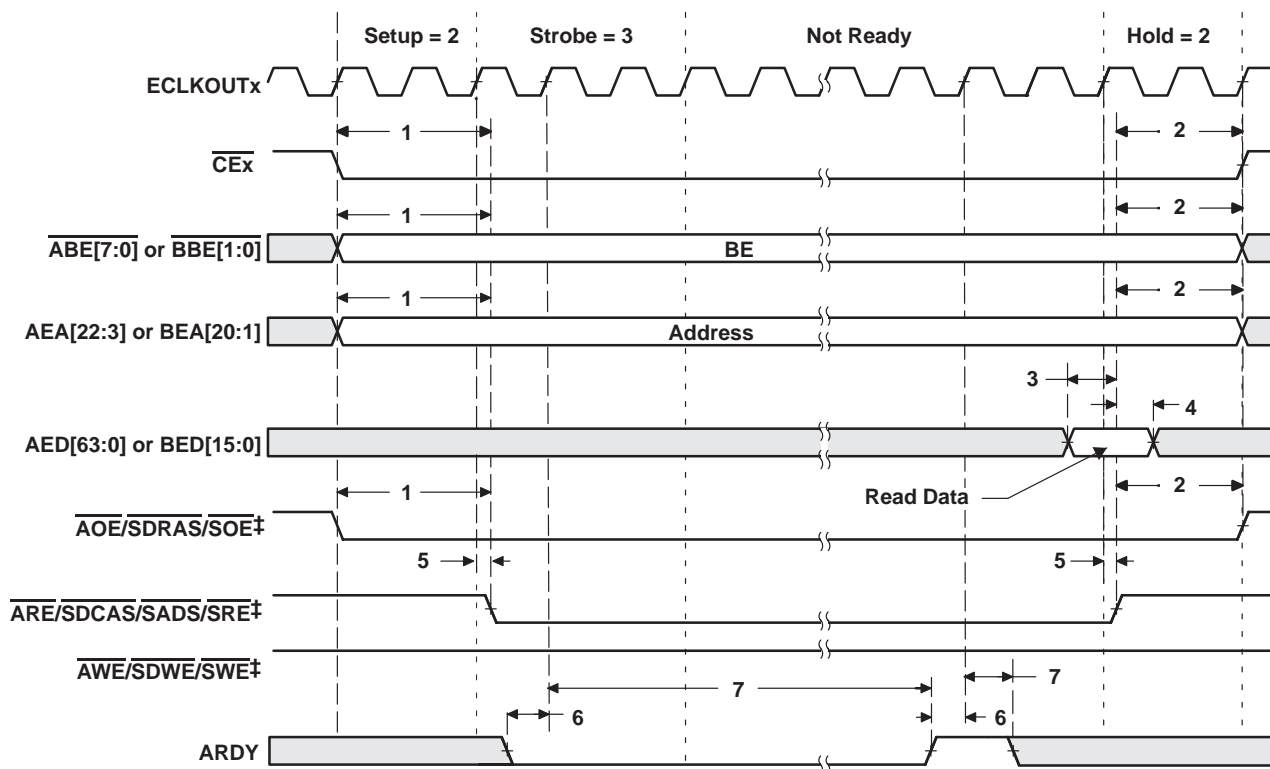

† These C64x™ devices have two EMIFs (EMIFA and EMIFB). All EMIFA signals are prefixed by an “A” and all EMIFB signals are prefixed by a “B”. Throughout the rest of this document, in generic EMIF areas of discussion, the prefix “A” or “B” may be omitted [e.g., the asynchronous memory access signals are shown as generic (AOE, ARE, and AWE) instead of AAOE, AARE, and AAW (for EMIFA) and BAOE, BARE, and BAW (for EMIFB)].

‡ AOE/SDRAS/SOE, ARE/SDCAS/SADS/SRE, and AWE/SDWE/SWE operate as AOE (identified under select signals), ARE, and AWE, respectively, during asynchronous memory accesses.

Figure 22. Asynchronous Memory Read Timing for EMIFA and EMIFB†

ASYNCHRONOUS MEMORY TIMING (CONTINUED)

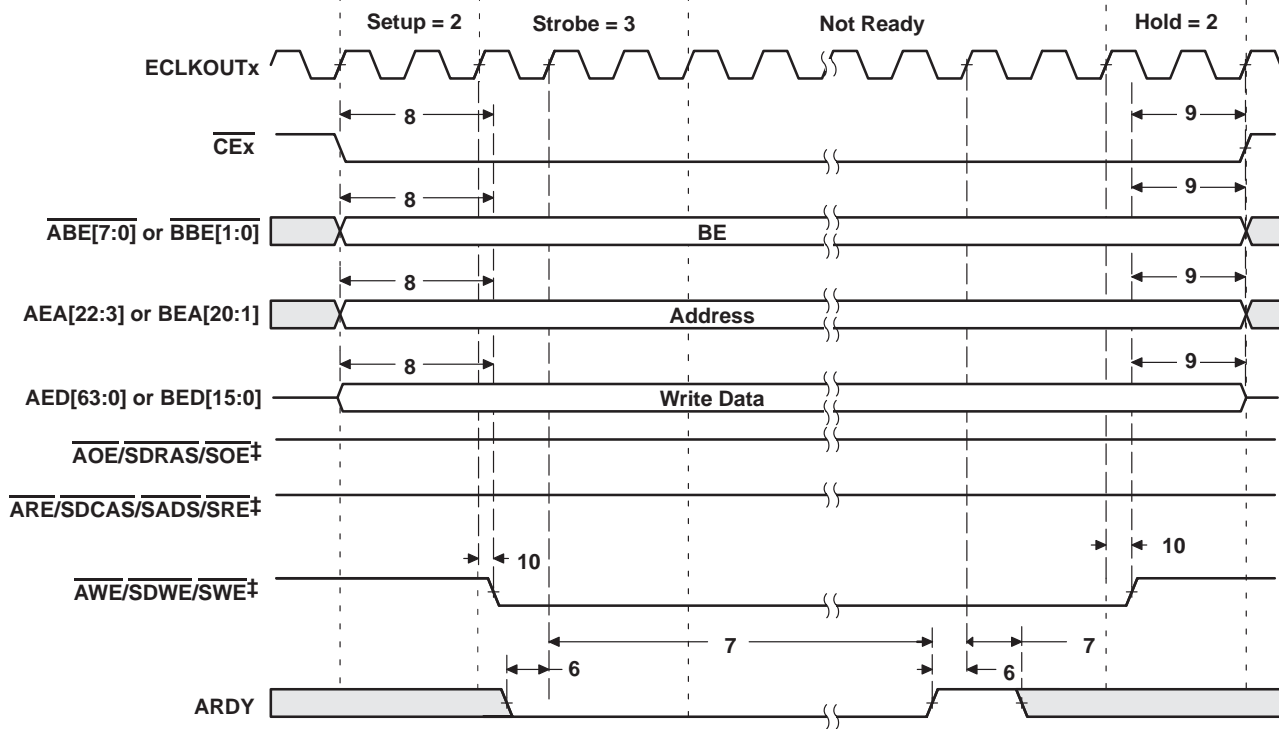

† These C64x™ devices have two EMIFs (EMIFA and EMIFB). All EMIFA signals are prefixed by an “A” and all EMIFB signals are prefixed by a “B”. Throughout the rest of this document, in generic EMIF areas of discussion, the prefix “A” or “B” may be omitted [e.g., the asynchronous memory access signals are shown as generic (AOE, ARE, and AWE) instead of AAOE, AARE, and AAWA (for EMIFA) and BAOE, BARE, and BAWA (for EMIFB)].

‡ AOE/SDRAS/SOE, ARE/SDCAS/SADS/SRE, and AWE/SDWE/SWE operate as AOE (identified under select signals), ARE, and AWE, respectively, during asynchronous memory accesses.

Figure 23. Asynchronous Memory Write Timing for EMIFA and EMIFB†

PROGRAMMABLE SYNCHRONOUS INTERFACE TIMING

timing requirements for programmable synchronous interface cycles for EMIFA module†
(see Figure 24)

| NO. | | -5E0 A-5E0 | | -6E3 A-6E3 -7E3 | | UNIT |
|-----|---|---------------|-----|-----------------------|-----|------|
| | | MIN | MAX | MIN | MAX | |
| 6 | t _{su} (EDV-EKOxH) Setup time, read EDx valid before ECLKOUTx high | 3.1 | | 2 | | ns |
| 7 | t _h (EKOxH-EDV) Hold time, read EDx valid after ECLKOUTx high | 1.5 | | 1.5 | | ns |

† These C64x™ devices have two EMIFs (EMIFA and EMIFB). All EMIFA signals are prefixed by an “A” and all EMIFB signals are prefixed by a “B”. Throughout the rest of this document, in generic EMIF areas of discussion, the prefix “A” or “B” may be omitted [e.g., the programmable synchronous interface access signals are shown as generic (SADS/SRE, SOE, and SWE) instead of ASADS/ASRE, ASOE, and ASWE (for EMIFA) and BSADS/BSRE, BSOE, and BSWE (for EMIFB)].

switching characteristics over recommended operating conditions for programmable synchronous interface cycles for EMIFA module†‡ (see Figure 24–Figure 26)

| NO. | PARAMETER | -5E0 A-5E0 | | -6E3 A-6E3 -7E3 | | UNIT |
|-----|---|---------------|-----|-----------------------|-----|------|
| | | MIN | MAX | MIN | MAX | |
| 1 | t _d (EKOxH-CEV) Delay time, ECLKOUTx high to $\overline{\text{CE}}_x$ valid | 1.3 | 6.4 | 1.3 | 4.9 | ns |
| 2 | t _d (EKOxH-BEV) Delay time, ECLKOUTx high to $\overline{\text{BE}}_x$ valid | | 6.4 | | 4.9 | ns |
| 3 | t _d (EKOxH-BEIV) Delay time, ECLKOUTx high to $\overline{\text{BE}}_x$ invalid | 1.3 | | 1.3 | | ns |
| 4 | t _d (EKOxH-EAV) Delay time, ECLKOUTx high to EA _x valid | | 6.4 | | 4.9 | ns |
| 5 | t _d (EKOxH-EAIV) Delay time, ECLKOUTx high to EA _x invalid | 1.3 | | 1.3 | | ns |
| 8 | t _d (EKOxH-ADSV) Delay time, ECLKOUTx high to $\overline{\text{SADS}}/\overline{\text{SRE}}$ valid | 1.3 | 6.4 | 1.3 | 4.9 | ns |
| 9 | t _d (EKOxH-OEV) Delay time, ECLKOUTx high to $\overline{\text{SOE}}$ valid | 1.3 | 6.4 | 1.3 | 4.9 | ns |
| 10 | t _d (EKOxH-EDV) Delay time, ECLKOUTx high to ED _x valid | | 6.4 | | 4.9 | ns |
| 11 | t _d (EKOxH-EDIV) Delay time, ECLKOUTx high to ED _x invalid | 1.3 | | 1.3 | | ns |
| 12 | t _d (EKOxH-WEV) Delay time, ECLKOUTx high to $\overline{\text{SWE}}$ valid | 1.3 | 6.4 | 1.3 | 4.9 | ns |

† These C64x™ devices have two EMIFs (EMIFA and EMIFB). All EMIFA signals are prefixed by an “A” and all EMIFB signals are prefixed by a “B”. Throughout the rest of this document, in generic EMIF areas of discussion, the prefix “A” or “B” may be omitted [e.g., the programmable synchronous interface access signals are shown as generic (SADS/SRE, SOE, and SWE) instead of ASADS/ASRE, ASOE, and ASWE (for EMIFA) and BSADS/BSRE, BSOE, and BSWE (for EMIFB)].

‡ The following parameters are programmable via the EMIF CE Space Secondary Control register (CEXSEC):

- Read latency (SYNCRL): 0-, 1-, 2-, or 3-cycle read latency
- Write latency (SYNCWL): 0-, 1-, 2-, or 3-cycle write latency
- CE_x assertion length (CEEXT): For standard SBSRAM or ZBT SRAM interface, $\overline{\text{CE}}_x$ goes inactive after the final command has been issued (CEEXT = 0). For synchronous FIFO interface with glue, $\overline{\text{CE}}_x$ is active when $\overline{\text{SOE}}$ is active (CEEXT = 1).
- Function of SADS/SRE (RENEN): For standard SBSRAM or ZBT SRAM interface, SADS/SRE acts as $\overline{\text{SADS}}$ with deselect cycles (RENEN = 0). For FIFO interface, SADS/SRE acts as SRE with NO deselect cycles (RENEN = 1).
- Synchronization clock (SNCKLK): Synchronized to ECLKOUT1 or ECLKOUT2

ADVANCE INFORMATION

TMS320C6414, TMS320C6415, TMS320C6416 FIXED-POINT DIGITAL SIGNAL PROCESSORS

SPRS146L – FEBRUARY 2001 – REVISED JULY 2004

PROGRAMMABLE SYNCHRONOUS INTERFACE TIMING (CONTINUED)

timing requirements for programmable synchronous interface cycles for EMIFB module†
(see Figure 24)

| NO. | | -5E0 A-5E0 | | -6E3 A-6E3 -7E3 | | UNIT |
|-----|---|---------------|-----|-----------------------|-----|------|
| | | MIN | MAX | MIN | MAX | |
| 6 | $t_{su}(EDV-EKOxH)$ Setup time, read EDx valid before ECLKOUTx high | 3.1 | | 3.1 | | ns |
| 7 | $t_h(EKOxH-EDV)$ Hold time, read EDx valid after ECLKOUTx high | 1.5 | | 1.5 | | ns |

† These C64x™ devices have two EMIFs (EMIFA and EMIFB). All EMIFA signals are prefixed by an “A” and all EMIFB signals are prefixed by a “B”. Throughout the rest of this document, in generic EMIF areas of discussion, the prefix “A” or “B” may be omitted [e.g., the programmable synchronous interface access signals are shown as generic ($\overline{SADS/SRE}$, \overline{SOE} , and \overline{SWE}) instead of $\overline{ASADS/ASRE}$, \overline{ASOE} , and \overline{ASWE} (for EMIFA) and $\overline{BSADS/BSRE}$, \overline{BSOE} , and \overline{BSWE} (for EMIFB)].

switching characteristics over recommended operating conditions for programmable synchronous interface cycles for EMIFB module†† (see Figure 24–Figure 26)

| NO. | PARAMETER | -5E0 A-5E0 | | -6E3 A-6E3 -7E3 | | UNIT |
|-----|--|---------------|-----|-----------------------|-----|------|
| | | MIN | MAX | MIN | MAX | |
| 1 | $t_d(EKOxH-CEV)$ Delay time, ECLKOUTx high to \overline{CEx} valid | 1.3 | 6.4 | 1.3 | 6.4 | ns |
| 2 | $t_d(EKOxH-BEV)$ Delay time, ECLKOUTx high to \overline{BEx} valid | | 6.4 | | 6.4 | ns |
| 3 | $t_d(EKOxH-BEIV)$ Delay time, ECLKOUTx high to \overline{BEx} invalid | 1.3 | | 1.3 | | ns |
| 4 | $t_d(EKOxH-EAV)$ Delay time, ECLKOUTx high to EAx valid | | 6.4 | | 6.4 | ns |
| 5 | $t_d(EKOxH-EAIV)$ Delay time, ECLKOUTx high to EAx invalid | 1.3 | | 1.3 | | ns |
| 8 | $t_d(EKOxH-ADSV)$ Delay time, ECLKOUTx high to $\overline{SADS/SRE}$ valid | 1.3 | 6.4 | 1.3 | 6.4 | ns |
| 9 | $t_d(EKOxH-OEV)$ Delay time, ECLKOUTx high to \overline{SOE} valid | 1.3 | 6.4 | 1.3 | 6.4 | ns |
| 10 | $t_d(EKOxH-EDV)$ Delay time, ECLKOUTx high to EDx valid | | 6.4 | | 6.4 | ns |
| 11 | $t_d(EKOxH-EDIV)$ Delay time, ECLKOUTx high to EDx invalid | 1.3 | | 1.3 | | ns |
| 12 | $t_d(EKOxH-WEV)$ Delay time, ECLKOUTx high to \overline{SWE} valid | 1.3 | 6.4 | 1.3 | 6.4 | ns |

† These C64x™ devices have two EMIFs (EMIFA and EMIFB). All EMIFA signals are prefixed by an “A” and all EMIFB signals are prefixed by a “B”. Throughout the rest of this document, in generic EMIF areas of discussion, the prefix “A” or “B” may be omitted [e.g., the programmable synchronous interface access signals are shown as generic ($\overline{SADS/SRE}$, \overline{SOE} , and \overline{SWE}) instead of $\overline{ASADS/ASRE}$, \overline{ASOE} , and \overline{ASWE} (for EMIFA) and $\overline{BSADS/BSRE}$, \overline{BSOE} , and \overline{BSWE} (for EMIFB)].

†† The following parameters are programmable via the EMIF CE Space Secondary Control register (CEXSEC):

- Read latency (SYNCRL): 0-, 1-, 2-, or 3-cycle read latency
- Write latency (SYNCWL): 0-, 1-, 2-, or 3-cycle write latency
- CEx assertion length (CEEXT): For standard SBSRAM or ZBT SRAM interface, \overline{CEx} goes inactive after the final command has been issued (CEEXT = 0). For synchronous FIFO interface with glue, \overline{CEx} is active when \overline{SOE} is active (CEEXT = 1).
- Function of $\overline{SADS/SRE}$ (RENEN): For standard SBSRAM or ZBT SRAM interface, $\overline{SADS/SRE}$ acts as \overline{SADS} with deselect cycles (RENEN = 0). For FIFO interface, $\overline{SADS/SRE}$ acts as \overline{SRE} with NO deselect cycles (RENEN = 1).
- Synchronization clock (SNCKLK): Synchronized to ECLKOUT1 or ECLKOUT2

ADVANCE INFORMATION



PROGRAMMABLE SYNCHRONOUS INTERFACE TIMING (CONTINUED)

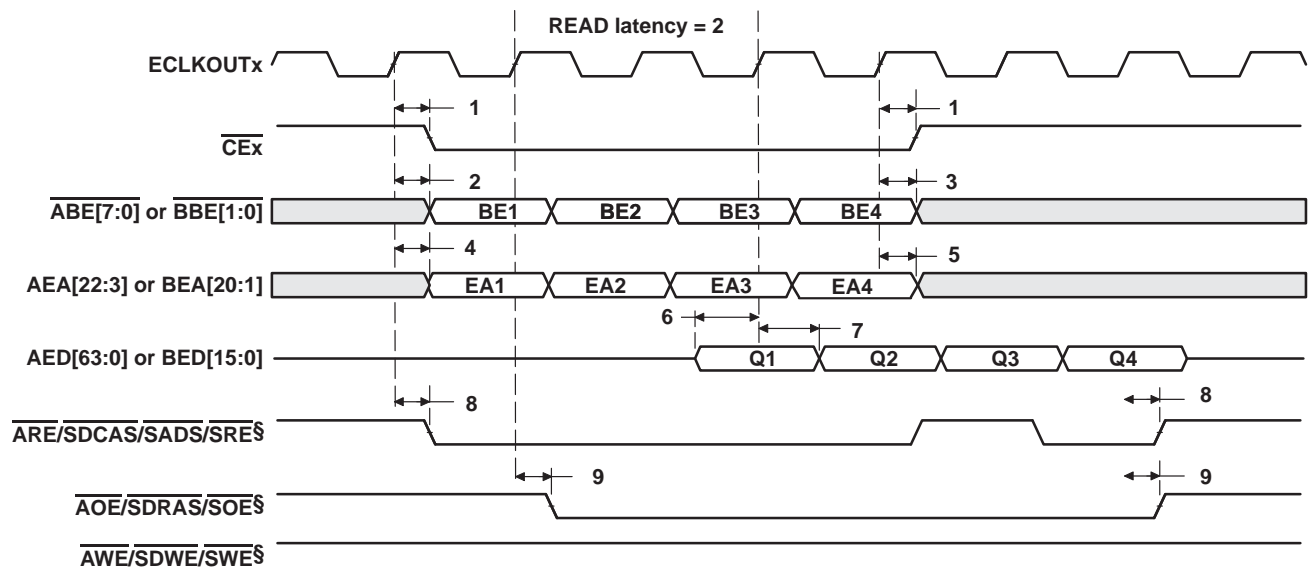

† These C64x™ devices have two EMIFs (EMIFA and EMIFB). All EMIFA signals are prefixed by an “A” and all EMIFB signals are prefixed by a “B”. Throughout the rest of this document, in generic EMIF areas of discussion, the prefix “A” or “B” may be omitted [e.g., the programmable synchronous interface access signals are shown as generic (SADS/SRE, SOE, and SWE) instead of ASADS/ASRE, ASOE, and ASWE (for EMIFA) and BSADS/BSRE, BSOE, and BSWE (for EMIFB)].

‡ The read latency and the length of CEx assertion are programmable via the SYNCRL and CEEXT fields, respectively, in the EMIFx CE Space Secondary Control register (CEXSEC). In this figure, SYNCRL = 2 and CEEXT = 0.

§ The following parameters are programmable via the EMIF CE Space Secondary Control register (CEXSEC):

- Read latency (SYNCRL): 0-, 1-, 2-, or 3-cycle read latency
- Write latency (SYNCWL): 0-, 1-, 2-, or 3-cycle write latency
- CEx assertion length (CEEXT): For standard SBSRAM or ZBT SRAM interface, CEx goes inactive after the final command has been issued (CEEXT = 0). For synchronous FIFO interface with glue, CEx is active when SOE is active (CEEXT = 1).
- Function of SADS/SRE (RENEN): For standard SBSRAM or ZBT SRAM interface, SADS/SRE acts as SADS with deselect cycles (RENEN = 0). For FIFO interface, SADS/SRE acts as SRE with NO deselect cycles (RENEN = 1).
- Synchronization clock (SNCKLK): Synchronized to ECLKOUT1 or ECLKOUT2

¶ ARE/SDCAS/SADS/SRE, AOE/SDRAS/SOE, and AWE/SDWE/SWE operate as SADS/SRE, SOE, and SWE, respectively, during programmable synchronous interface accesses.

Figure 24. Programmable Synchronous Interface Read Timing for EMIFA and EMIFB
(With Read Latency = 2)†‡§

ADVANCE INFORMATION

PROGRAMMABLE SYNCHRONOUS INTERFACE TIMING (CONTINUED)

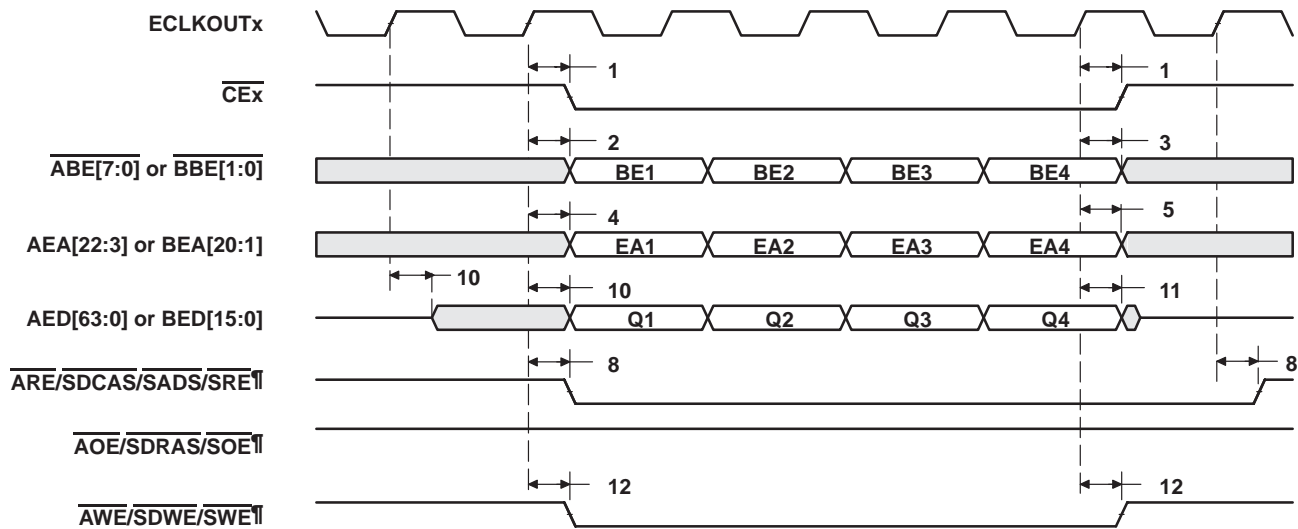

† These C64x™ devices have two EMIFs (EMIFA and EMIFB). All EMIFA signals are prefixed by an “A” and all EMIFB signals are prefixed by a “B”. Throughout the rest of this document, in generic EMIF areas of discussion, the prefix “A” or “B” may be omitted [e.g., the programmable synchronous interface access signals are shown as generic (SADS/SRE, SOE, and SWE) instead of ASADS/ASRE, ASOE, and ASWE (for EMIFA) and BSADS/BSRE, BSOE, and BSWE (for EMIFB)].

‡ The write latency and the length of CEx assertion are programmable via the SYNCWL and CEEXT fields, respectively, in the EMIFx CE Space Secondary Control register (CExSEC). In this figure, SYNCWL = 0 and CEEXT = 0.

§ The following parameters are programmable via the EMIF CE Space Secondary Control register (CExSEC):

- Read latency (SYNCRL): 0-, 1-, 2-, or 3-cycle read latency
- Write latency (SYNCWL): 0-, 1-, 2-, or 3-cycle write latency
- CEx assertion length (CEEXT): For standard SBSRAM or ZBT SRAM interface, CEx goes inactive after the final command has been issued (CEEXT = 0). For synchronous FIFO interface with glue, CEx is active when SOE is active (CEEXT = 1).
- Function of SADS/SRE (RENEN): For standard SBSRAM or ZBT SRAM interface, SADS/SRE acts as SADS with deselect cycles (RENEN = 0). For FIFO interface, SADS/SRE acts as SRE with NO deselect cycles (RENEN = 1).
- Synchronization clock (SNCCLK): Synchronized to ECLKOUT1 or ECLKOUT2

¶ ARE/SDCAS/SADS/SRE, AOE/SDRAS/SOE, and AWE/SDWE/SWE operate as SADS/SRE, SOE, and SWE, respectively, during programmable synchronous interface accesses.

Figure 25. Programmable Synchronous Interface Write Timing for EMIFA and EMIFB
 (With Write Latency = 0)†‡§

ADVANCE INFORMATION

PROGRAMMABLE SYNCHRONOUS INTERFACE TIMING (CONTINUED)

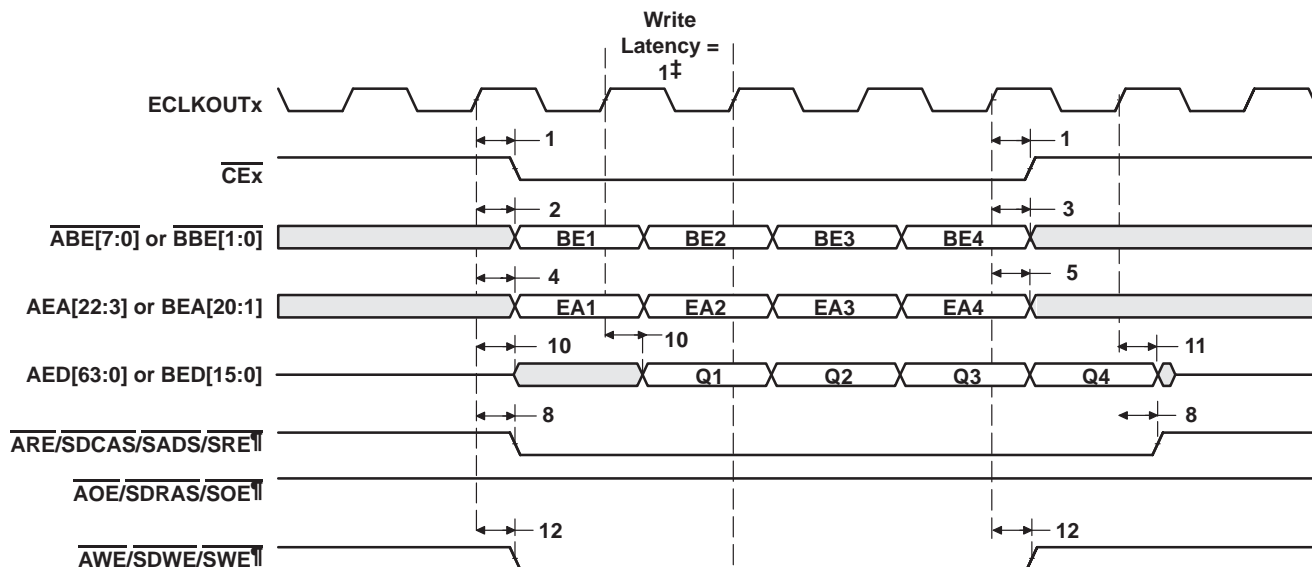

† These C64x™ devices have two EMIFs (EMIFA and EMIFB). All EMIFA signals are prefixed by an “A” and all EMIFB signals are prefixed by a “B”. Throughout the rest of this document, in generic EMIF areas of discussion, the prefix “A” or “B” may be omitted [e.g., the programmable synchronous interface access signals are shown as generic (SADS/SRE, SOE, and SWE) instead of ASADS/ASRE, ASOE, and ASWE (for EMIFA) and BSADS/BSRE, BSOE, and BSWE (for EMIFB)].

‡ The write latency and the length of CEx assertion are programmable via the SYNCWL and CEEXT fields, respectively, in the EMIFx CE Space Secondary Control register (CEXSEC). In this figure, SYNCWL = 1 and CEEXT = 0.

§ The following parameters are programmable via the EMIF CE Space Secondary Control register (CEXSEC):

- Read latency (SYNCRL): 0-, 1-, 2-, or 3-cycle read latency
- Write latency (SYNCWL): 0-, 1-, 2-, or 3-cycle write latency
- CEx assertion length (CEEXT): For standard SBSRAM or ZBT SRAM interface, CEx goes inactive after the final command has been issued (CEEXT = 0). For synchronous FIFO interface with glue, CEx is active when SOE is active (CEEXT = 1).
- Function of SADS/SRE (RENEN): For standard SBSRAM or ZBT SRAM interface, SADS/SRE acts as SADS with deselect cycles (RENEN = 0). For FIFO interface, SADS/SRE acts as SRE with NO deselect cycles (RENEN = 1).
- Synchronization clock (SNCCLK): Synchronized to ECLKOUT1 or ECLKOUT2

¶ ARE/SDCAS/SADS/SRE, AOE/SDRAS/SOE, and AWE/SDWE/SWE operate as SADS/SRE, SOE, and SWE, respectively, during programmable synchronous interface accesses.

Figure 26. Programmable Synchronous Interface Write Timing for EMIFA and EMIFB
(With Write Latency = 1)†‡§

TMS320C6414, TMS320C6415, TMS320C6416 FIXED-POINT DIGITAL SIGNAL PROCESSORS

SPRS146L – FEBRUARY 2001 – REVISED JULY 2004

SYNCHRONOUS DRAM TIMING

timing requirements for synchronous DRAM cycles for EMIFA module† (see Figure 27)

| NO. | | -5E0 A-5E0 | | -6E3 A-6E3 -7E3 | | UNIT |
|-----|---|---------------|-----|-----------------------|-----|------|
| | | MIN | MAX | MIN | MAX | |
| 6 | t _{su} (EDV-EKO1H) Setup time, read EDx valid before ECLKOUTx high | 2.1 | | 0.6 | | ns |
| 7 | t _h (EKO1H-EDV) Hold time, read EDx valid after ECLKOUTx high | 2.5 | | 1.8 | | ns |

† These C64x™ devices have two EMIFs (EMIFA and EMIFB). All EMIFA signals are prefixed by an “A” and all EMIFB signals are prefixed by a “B”. Throughout the rest of this document, in generic EMIF areas of discussion, the prefix “A” or “B” may be omitted [e.g., the synchronous DRAM memory access signals are shown as generic (SDCAS, SDWE, and SDRAS) instead of ASDCAS, ASDWE, and ASDRAS (for EMIFA) and BSDCAS, BSDWE, and BSDRAS (for EMIFB)].

switching characteristics over recommended operating conditions for synchronous DRAM cycles for EMIFA module† (see Figure 27–Figure 34)

| NO. | PARAMETER | -5E0 A-5E0 | | -6E3 A-6E3 -7E3 | | UNIT |
|-----|---|---------------|-----|-----------------------|-----|------|
| | | MIN | MAX | MIN | MAX | |
| 1 | t _d (EKO1H-CEV) Delay time, ECLKOUTx high to <u>CEx</u> valid | 1.3 | 6.4 | 1.3 | 4.9 | ns |
| 2 | t _d (EKO1H-BEV) Delay time, ECLKOUTx high to <u>BEx</u> valid | | 6.4 | | 4.9 | ns |
| 3 | t _d (EKO1H-BEIV) Delay time, ECLKOUTx high to <u>BEx</u> invalid | 1.3 | | 1.3 | | ns |
| 4 | t _d (EKO1H-EAV) Delay time, ECLKOUTx high to <u>EAx</u> valid | | 6.4 | | 4.9 | ns |
| 5 | t _d (EKO1H-EAIV) Delay time, ECLKOUTx high to <u>EAx</u> invalid | 1.3 | | 1.3 | | ns |
| 8 | t _d (EKO1H-CASV) Delay time, ECLKOUTx high to <u>SDCAS</u> valid | 1.3 | 6.4 | 1.3 | 4.9 | ns |
| 9 | t _d (EKO1H-EDV) Delay time, ECLKOUTx high to EDx valid | | 6.4 | | 4.9 | ns |
| 10 | t _d (EKO1H-EDIV) Delay time, ECLKOUTx high to EDx invalid | 1.3 | | 1.3 | | ns |
| 11 | t _d (EKO1H-WEV) Delay time, ECLKOUTx high to <u>SDWE</u> valid | 1.3 | 6.4 | 1.3 | 4.9 | ns |
| 12 | t _d (EKO1H-RAS) Delay time, ECLKOUTx high to <u>SDRAS</u> valid | 1.3 | 6.4 | 1.3 | 4.9 | ns |
| 13 | t _d (EKO1H-ACKEV) Delay time, ECLKOUTx high to ASDCKE valid (EMIFA only) | 1.3 | 6.4 | 1.3 | 4.9 | ns |
| 14 | t _d (EKO1H-PDTV) Delay time, ECLKOUTx high to <u>PDT</u> valid | 1.3 | 6.4 | 1.3 | 4.9 | ns |

† These C64x™ devices have two EMIFs (EMIFA and EMIFB). All EMIFA signals are prefixed by an “A” and all EMIFB signals are prefixed by a “B”. Throughout the rest of this document, in generic EMIF areas of discussion, the prefix “A” or “B” may be omitted [e.g., the synchronous DRAM memory access signals are shown as generic (SDCAS, SDWE, and SDRAS) instead of ASDCAS, ASDWE, and ASDRAS (for EMIFA) and BSDCAS, BSDWE, and BSDRAS (for EMIFB)].

ADVANCE INFORMATION



SYNCHRONOUS DRAM TIMING (CONTINUED)

timing requirements for synchronous DRAM cycles for EMIFB module† (see Figure 27)

| NO. | | -5E0 A-5E0 | | -6E3 A-6E3 -7E3 | | UNIT |
|-----|---|---------------|-----|-----------------------|-----|------|
| | | MIN | MAX | MIN | MAX | |
| 6 | $t_{su}(EDV-EKO1H)$ Setup time, read EDx valid before ECLKOUTx high | 2.1 | | 2.1 | | ns |
| 7 | $t_h(EKO1H-EDV)$ Hold time, read EDx valid after ECLKOUTx high | 2.5 | | 2.5 | | ns |

† These C64x™ devices have two EMIFs (EMIFA and EMIFB). All EMIFA signals are prefixed by an “A” and all EMIFB signals are prefixed by a “B”. Throughout the rest of this document, in generic EMIF areas of discussion, the prefix “A” or “B” may be omitted [e.g., the synchronous DRAM memory access signals are shown as generic (\overline{SDCAS} , \overline{SDWE} , and \overline{SDRAS}) instead of \overline{ASDCAS} , \overline{ASDWE} , and \overline{ASDRAS} (for EMIFA) and \overline{BSDCAS} , \overline{BSDWE} , and \overline{BSDRAS} (for EMIFB)].

switching characteristics over recommended operating conditions for synchronous DRAM cycles for EMIFB module† (see Figure 27–Figure 34)

| NO. | PARAMETER | -5E0 A-5E0 | | -6E3 A-6E3 -7E3 | | UNIT |
|-----|---|---------------|-----|-----------------------|-----|------|
| | | MIN | MAX | MIN | MAX | |
| 1 | $t_d(EKO1H-CEV)$ Delay time, ECLKOUTx high to \overline{CEx} valid | 1.3 | 6.4 | 1.3 | 6.4 | ns |
| 2 | $t_d(EKO1H-BEV)$ Delay time, ECLKOUTx high to \overline{BEx} valid | | 6.4 | | 6.4 | ns |
| 3 | $t_d(EKO1H-BEIV)$ Delay time, ECLKOUTx high to \overline{BEx} invalid | 1.3 | | 1.3 | | ns |
| 4 | $t_d(EKO1H-EAV)$ Delay time, ECLKOUTx high to EAx valid | | 6.4 | | 6.4 | ns |
| 5 | $t_d(EKO1H-EAIV)$ Delay time, ECLKOUTx high to EAx invalid | 1.3 | | 1.3 | | ns |
| 8 | $t_d(EKO1H-CASV)$ Delay time, ECLKOUTx high to \overline{SDCAS} valid | 1.3 | 6.4 | 1.3 | 6.4 | ns |
| 9 | $t_d(EKO1H-EDV)$ Delay time, ECLKOUTx high to EDx valid | | 6.4 | | 6.4 | ns |
| 10 | $t_d(EKO1H-EDIV)$ Delay time, ECLKOUTx high to EDx invalid | 1.3 | | 1.3 | | ns |
| 11 | $t_d(EKO1H-WEV)$ Delay time, ECLKOUTx high to \overline{SDWE} valid | 1.3 | 6.4 | 1.3 | 6.4 | ns |
| 12 | $t_d(EKO1H-RAS)$ Delay time, ECLKOUTx high to \overline{SDRAS} valid | 1.3 | 6.4 | 1.3 | 6.4 | ns |
| 13 | $t_d(EKO1H-ACKEV)$ Delay time, ECLKOUTx high to ASDCKE valid (EMIFA only) | 1.3 | 6.4 | 1.3 | 6.4 | ns |
| 14 | $t_d(EKO1H-PDTV)$ Delay time, ECLKOUTx high to \overline{PDT} valid | 1.3 | 6.4 | 1.3 | 6.4 | ns |

† These C64x™ devices have two EMIFs (EMIFA and EMIFB). All EMIFA signals are prefixed by an “A” and all EMIFB signals are prefixed by a “B”. Throughout the rest of this document, in generic EMIF areas of discussion, the prefix “A” or “B” may be omitted [e.g., the synchronous DRAM memory access signals are shown as generic (\overline{SDCAS} , \overline{SDWE} , and \overline{SDRAS}) instead of \overline{ASDCAS} , \overline{ASDWE} , and \overline{ASDRAS} (for EMIFA) and \overline{BSDCAS} , \overline{BSDWE} , and \overline{BSDRAS} (for EMIFB)].

ADVANCE INFORMATION

SYNCHRONOUS DRAM TIMING (CONTINUED)

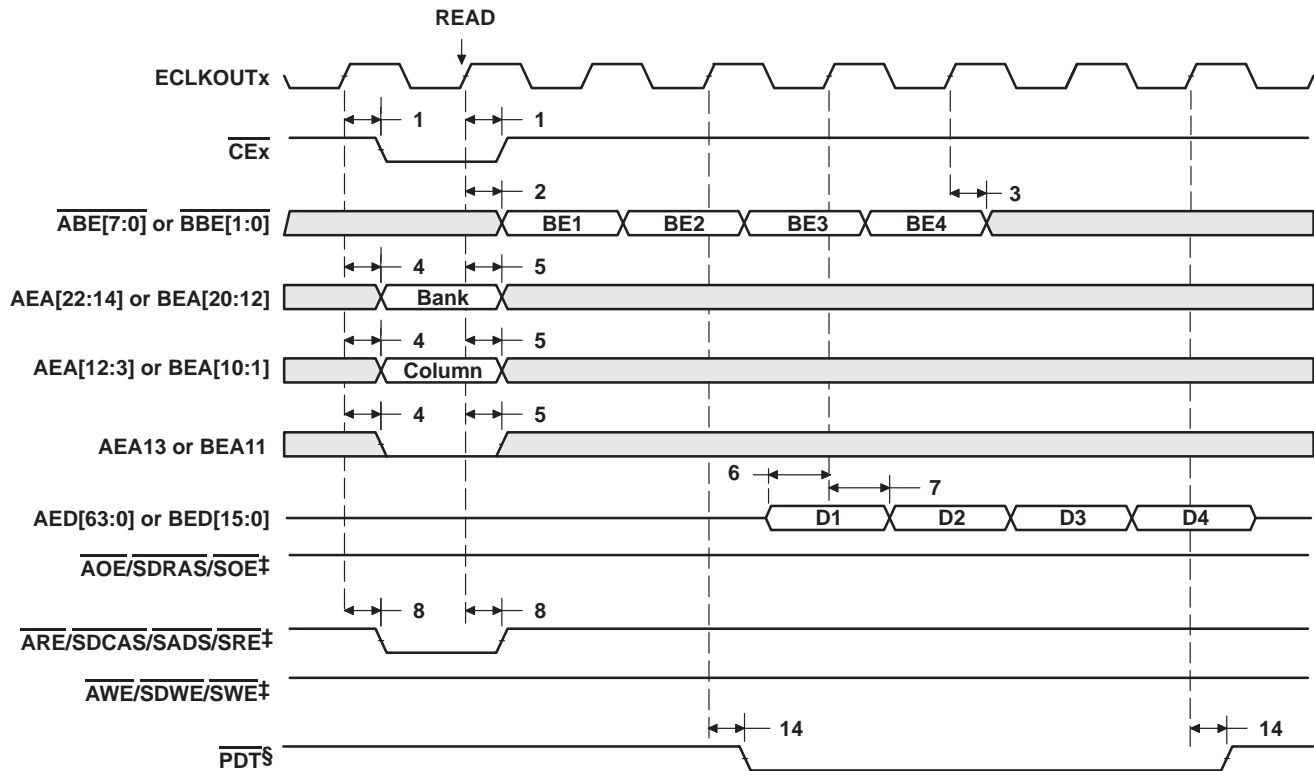

ADVANCE INFORMATION

† These C64x™ devices have two EMIFs (EMIFA and EMIFB). All EMIFA signals are prefixed by an “A” and all EMIFB signals are prefixed by a “B”. Throughout the rest of this document, in generic EMIF areas of discussion, the prefix “A” or “B” may be omitted [e.g., the synchronous DRAM memory access signals are shown as generic ($\overline{\text{SDCAS}}$, $\overline{\text{SDWE}}$, and $\overline{\text{SDRAS}}$) instead of $\overline{\text{ASDCAS}}$, $\overline{\text{ASDWE}}$, and $\overline{\text{ASDRAS}}$ (for EMIFA) and $\overline{\text{BSDCAS}}$, $\overline{\text{BSDWE}}$, and $\overline{\text{BSDRAS}}$ (for EMIFB)].

‡ $\overline{\text{ARE/SDCAS/SADS/SRE}}$, $\overline{\text{AWE/SDWE/SWE}}$, and $\overline{\text{AOE/SDRAS/SOE}}$ operate as $\overline{\text{SDCAS}}$, $\overline{\text{SDWE}}$, and $\overline{\text{SDRAS}}$, respectively, during SDRAM accesses.

§ $\overline{\text{PDT}}$ signal is only asserted when the EDMA is in PDT mode (set the PDTS bit to 1 in the EDMA options parameter RAM). For $\overline{\text{PDT}}$ read, data is not latched into EMIF. The PDTRL field in the PDT control register (PDTCTL) configures the latency of the $\overline{\text{PDT}}$ signal with respect to the data phase of a read transaction. The latency of the $\overline{\text{PDT}}$ signal for a read can be programmed to 0, 1, 2, or 3 by setting PDTRL to 00, 01, 10, or 11, respectively. PDTRL equals 00 (zero latency) in Figure 27.

Figure 27. SDRAM Read Command (CAS Latency 3) for EMIFA and EMIFB†

SYNCHRONOUS DRAM TIMING (CONTINUED)

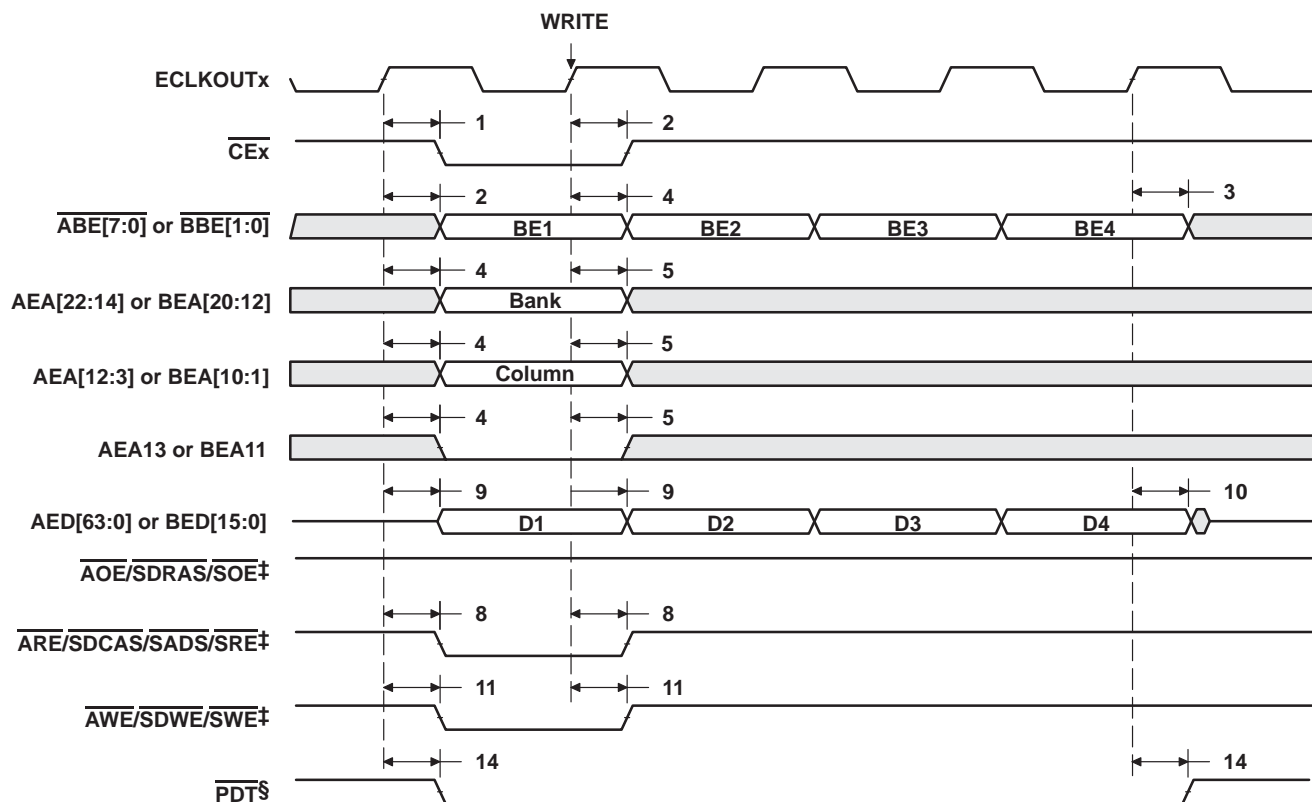

† These C64x™ devices have two EMIFs (EMIFA and EMIFB). All EMIFA signals are prefixed by an “A” and all EMIFB signals are prefixed by a “B”. Throughout the rest of this document, in generic EMIF areas of discussion, the prefix “A” or “B” may be omitted [e.g., the synchronous DRAM memory access signals are shown as generic (SDCAS, SDWE, and SDRAS) instead of ASDCAS, ASDWE, and ASDRAS (for EMIFA) and BSDCAS, BSDWE, and BSDRAS (for EMIFB)].

‡ ARE/SDCAS/SADS/SRE, AWE/SDWE/SWE, and AOE/SDRAS/SOE operate as SDCAS, SDWE, and SDRAS, respectively, during SDRAM accesses.

§ PDT signal is only asserted when the EDMA is in PDT mode (set the PDTD bit to 1 in the EDMA options parameter RAM). For PDT write, data is not driven (in High-Z). The PDTWL field in the PDT control register (PDTCTL) configures the latency of the PDT signal with respect to the data phase of a write transaction. The latency of the PDT signal for a write transaction can be programmed to 0, 1, 2, or 3 by setting PDTWL to 00, 01, 10, or 11, respectively. PDTWL equals 00 (zero latency) in Figure 28.

Figure 28. SDRAM Write Command for EMIFA and EMIFB†

SYNCHRONOUS DRAM TIMING (CONTINUED)

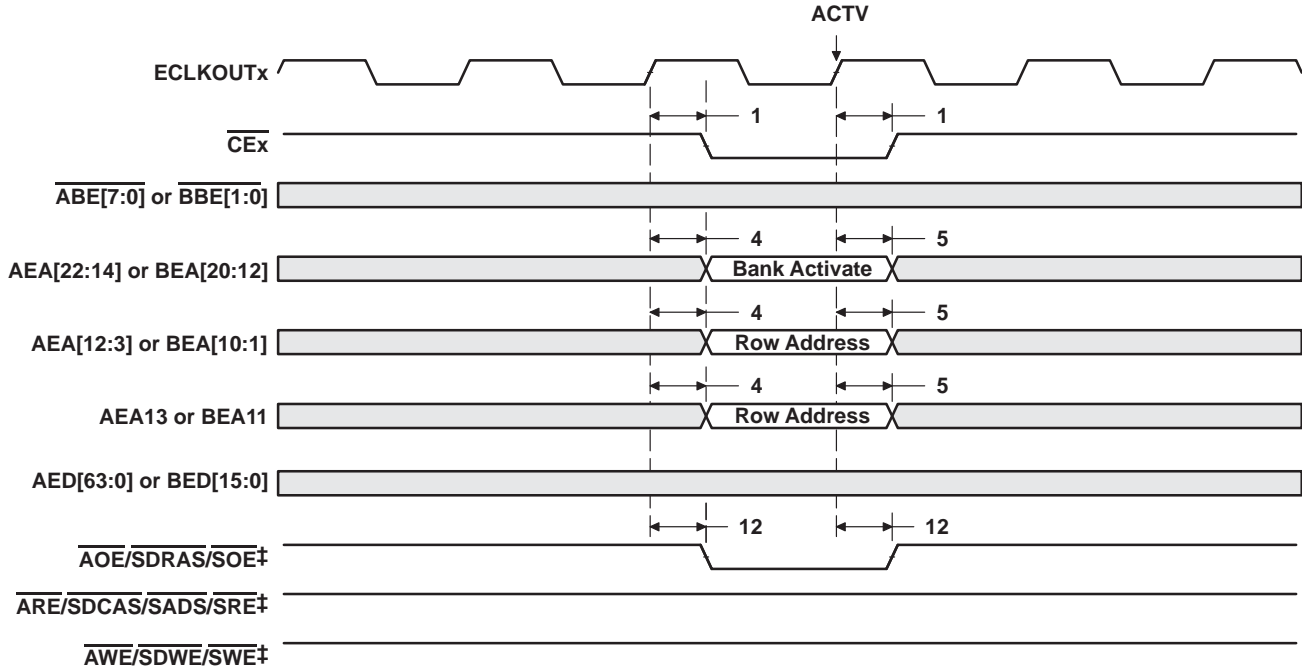

† These C64x™ devices have two EMIFs (EMIFA and EMIFB). All EMIFA signals are prefixed by an “A” and all EMIFB signals are prefixed by a “B”. Throughout the rest of this document, in generic EMIF areas of discussion, the prefix “A” or “B” may be omitted [e.g., the synchronous DRAM memory access signals are shown as generic ($\overline{\text{SDCAS}}$, $\overline{\text{SDWE}}$, and $\overline{\text{SDRAS}}$) instead of $\overline{\text{ASDCAS}}$, $\overline{\text{ASDWE}}$, and $\overline{\text{ASDRAS}}$ (for EMIFA) and $\overline{\text{BSDCAS}}$, $\overline{\text{BSDWE}}$, and $\overline{\text{BSDRAS}}$ (for EMIFB)].

‡ $\overline{\text{ARE/SDCAS/SADS/SRE}}$, $\overline{\text{AWE/SDWE/SWE}}$, and $\overline{\text{AOE/SDRAS/SOE}}$ operate as $\overline{\text{SDCAS}}$, $\overline{\text{SDWE}}$, and $\overline{\text{SDRAS}}$, respectively, during SDRAM accesses.

Figure 29. SDRAM ACTV Command for EMIFA and EMFB†

SYNCHRONOUS DRAM TIMING (CONTINUED)

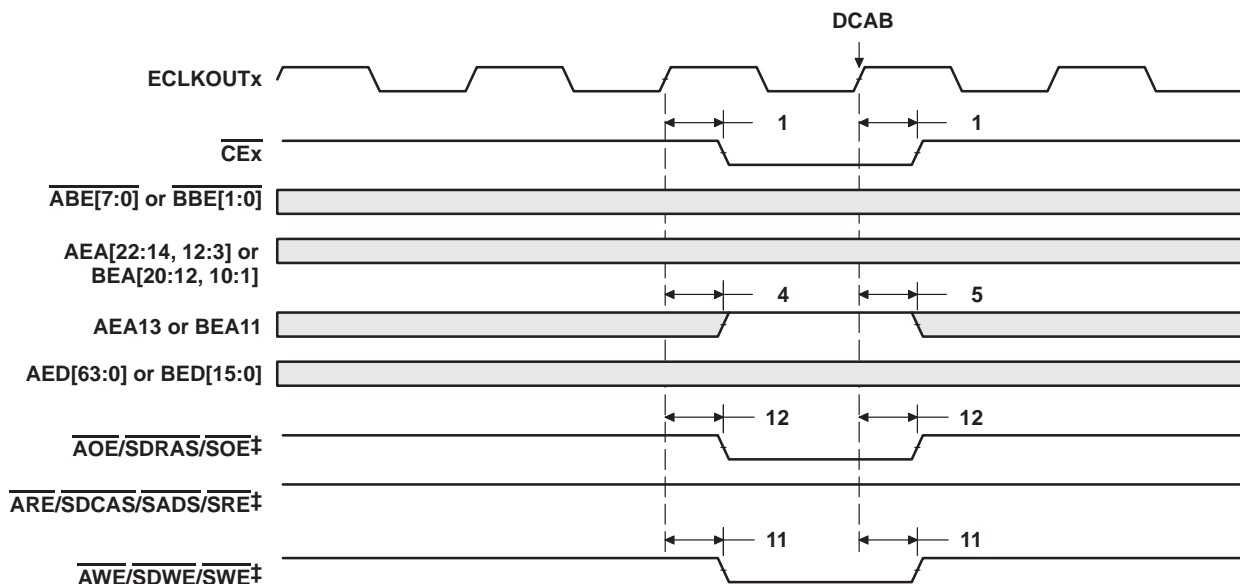

† These C64x™ devices have two EMIFs (EMIFA and EMIFB). All EMIFA signals are prefixed by an “A” and all EMIFB signals are prefixed by a “B”. Throughout the rest of this document, in generic EMIF areas of discussion, the prefix “A” or “B” may be omitted [e.g., the synchronous DRAM memory access signals are shown as generic (SDCAS, SDWE, and SDRAS) instead of ASDCAS, ASDWE, and ASDRAS (for EMIFA) and BSDCAS, BSDWE, and BSDRAS (for EMIFB)].

‡ ARE/SDCAS/SADS/SRE, AWE/SDWE/SWE, and AOE/SDRAS/SOE operate as SDCAS, SDWE, and SDRAS, respectively, during SDRAM accesses.

Figure 30. SDRAM DCAB Command for EMIFA and EMIFB†

SYNCHRONOUS DRAM TIMING (CONTINUED)

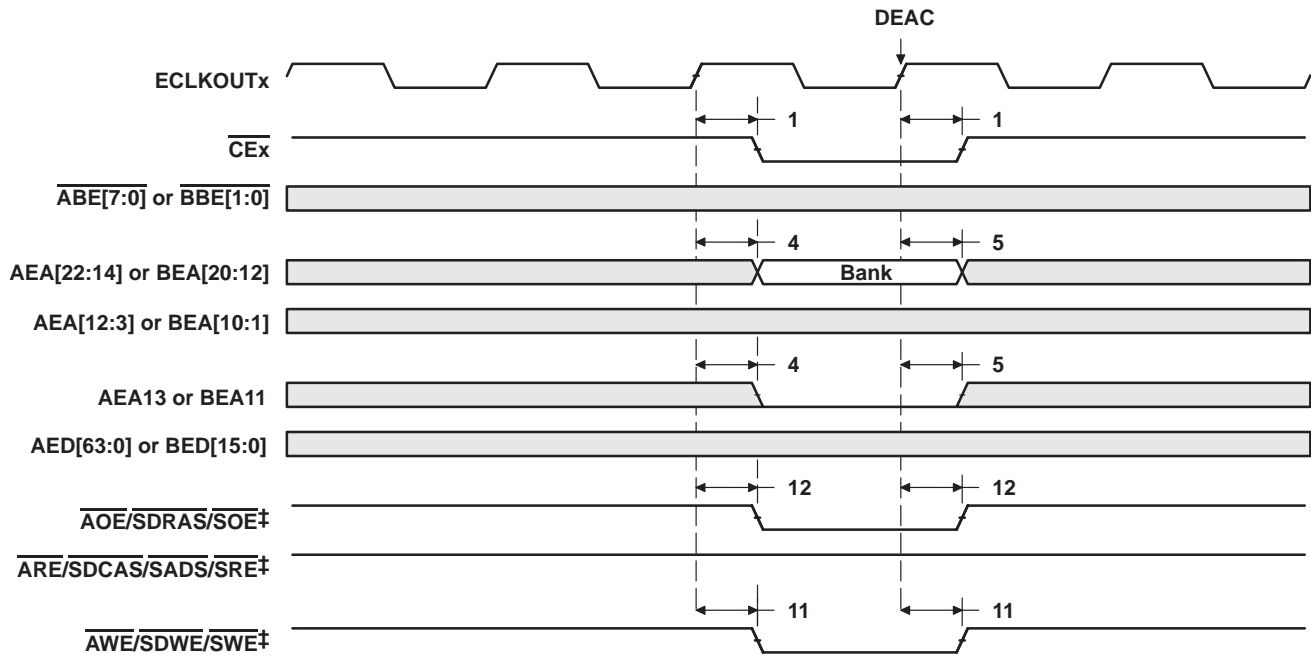

† These C64x™ devices have two EMIFs (EMIFA and EMIFB). All EMIFA signals are prefixed by an "A" and all EMIFB signals are prefixed by a "B". Throughout the rest of this document, in generic EMIF areas of discussion, the prefix "A" or "B" may be omitted [e.g., the synchronous DRAM memory access signals are shown as generic (SDCAS, SDWE, and SDRAS) instead of ASDCAS, ASDWE, and ASDRAS (for EMIFA) and BSDCAS, BSDWE, and BSDRAS (for EMIFB)].

‡ ARE/SDCAS/SADS/SRE, AWE/SDWE/SWE, and AOE/SDRAS/SOE operate as SDCAS, SDWE, and SDRAS, respectively, during SDRAM accesses.

Figure 31. SDRAM DEAC Command for EMIFA and EMIFB†

SYNCHRONOUS DRAM TIMING (CONTINUED)

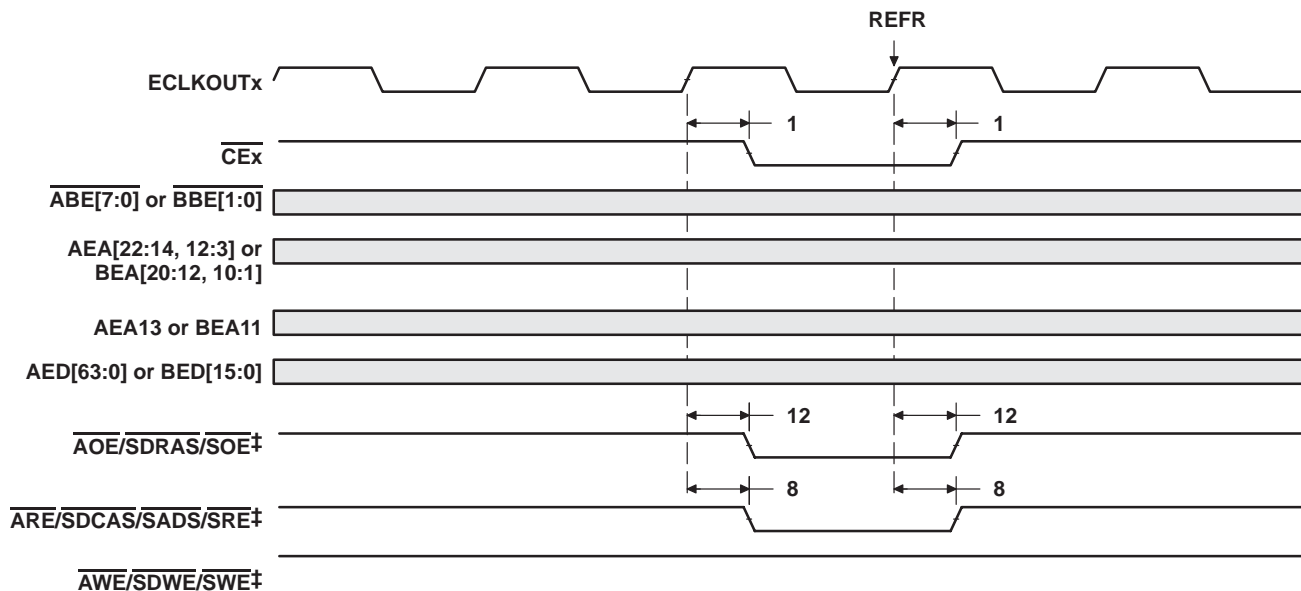

† These C64x™ devices have two EMIFs (EMIFA and EMIFB). All EMIFA signals are prefixed by an “A” and all EMIFB signals are prefixed by a “B”. Throughout the rest of this document, in generic EMIF areas of discussion, the prefix “A” or “B” may be omitted [e.g., the synchronous DRAM memory access signals are shown as generic ($\overline{\text{SDCAS}}$, $\overline{\text{SDWE}}$, and $\overline{\text{SDRAS}}$) instead of $\overline{\text{ASDCAS}}$, $\overline{\text{ASDWE}}$, and $\overline{\text{ASDRAS}}$ (for EMIFA) and $\overline{\text{BSDCAS}}$, $\overline{\text{BSDWE}}$, and $\overline{\text{BSDRAS}}$ (for EMIFB)].

‡ $\overline{\text{ARE/SDCAS/SADS/SRE}}$, $\overline{\text{AWE/SDWE/SWE}}$, and $\overline{\text{AOE/SDRAS/SOE}}$ operate as $\overline{\text{SDCAS}}$, $\overline{\text{SDWE}}$, and $\overline{\text{SDRAS}}$, respectively, during SDRAM accesses.

Figure 32. SDRAM REFR Command for EMIFA and EMIFB†

SYNCHRONOUS DRAM TIMING (CONTINUED)

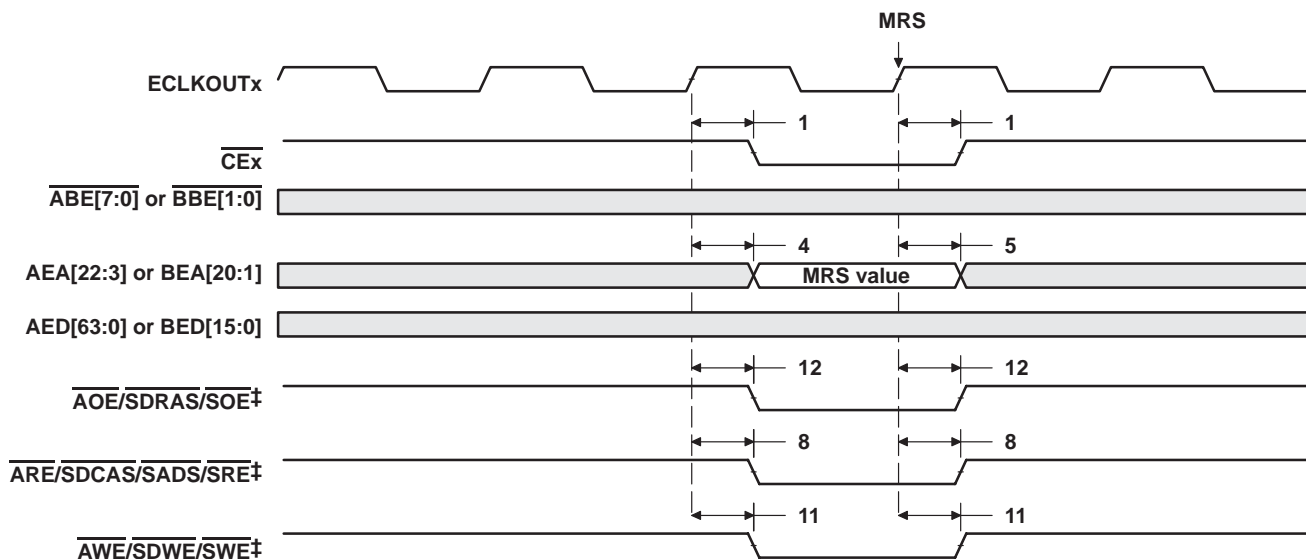

† These C64x™ devices have two EMIFs (EMIFA and EMIFB). All EMIFA signals are prefixed by an “A” and all EMIFB signals are prefixed by a “B”. Throughout the rest of this document, in generic EMIF areas of discussion, the prefix “A” or “B” may be omitted [e.g., the synchronous DRAM memory access signals are shown as generic ($\overline{\text{SDCAS}}$, $\overline{\text{SDWE}}$, and $\overline{\text{SDRAS}}$) instead of $\overline{\text{ASDCAS}}$, $\overline{\text{ASDWE}}$, and $\overline{\text{ASDRAS}}$ (for EMIFA) and $\overline{\text{BSDCAS}}$, $\overline{\text{BSDWE}}$, and $\overline{\text{BSDRAS}}$ (for EMIFB)].

‡ $\overline{\text{ARE/SDCAS/SADS/SRE}}$, $\overline{\text{AWE/SDWE/SWE}}$, and $\overline{\text{AOE/SDRAS/SOE}}$ operate as $\overline{\text{SDCAS}}$, $\overline{\text{SDWE}}$, and $\overline{\text{SDRAS}}$, respectively, during SDRAM accesses.

Figure 33. SDRAM MRS Command for EMIFA and EMIFB†

SYNCHRONOUS DRAM TIMING (CONTINUED)

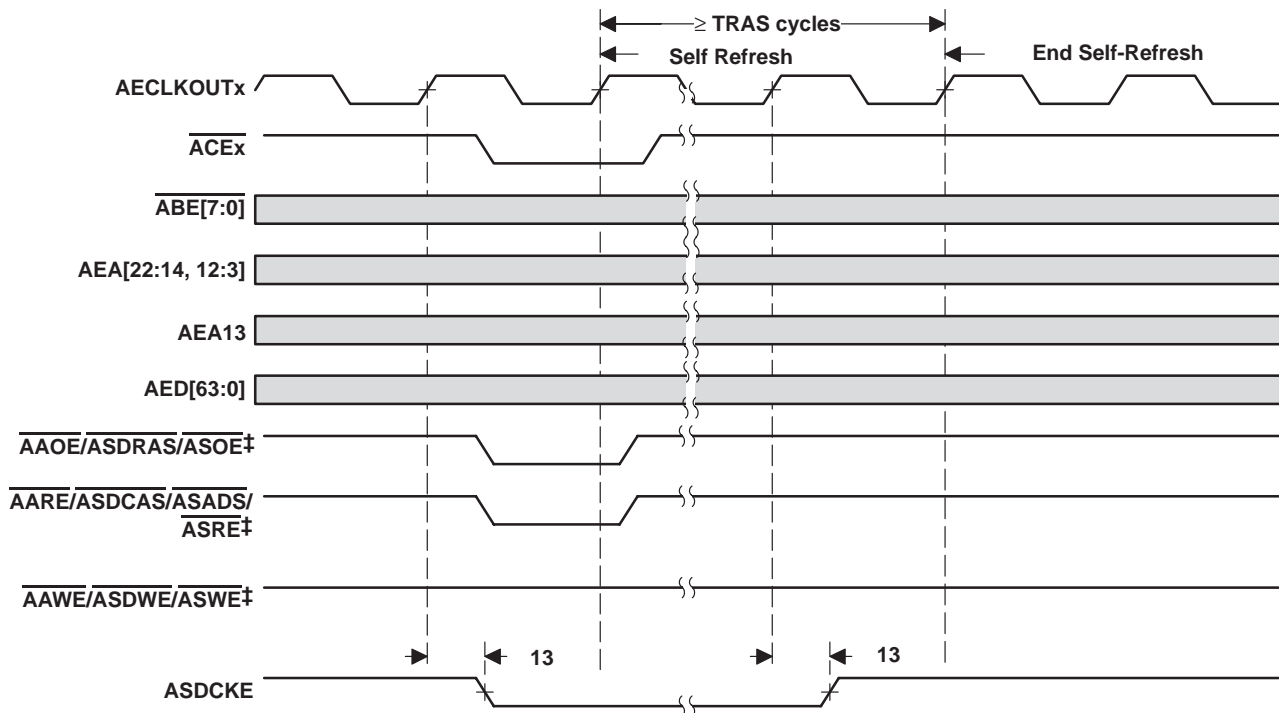

† These C64x™ devices have two EMIFs (EMIFA and EMIFB). All EMIFA signals are prefixed by an “A” and all EMIFB signals are prefixed by a “B”. Throughout the rest of this document, in generic EMIF areas of discussion, the prefix “A” or “B” may be omitted [e.g., the synchronous DRAM memory access signals are shown as generic (SDCAS, SDWE, and SDRAS) instead of ASDCAS, ASDWE, and ASDRAS (for EMIFA) and BSDCAS, BSDWE, and BSDRAS (for EMIFB)].

‡ AARE/ASDCAS/ASADS/ASRE, AAWE/ASDWE/ASWE, and AAOE/ASDRAS/ASOE operate as ASDCAS, ASDWE, and ASDRAS, respectively, during SDRAM accesses.

Figure 34. SDRAM Self-Refresh Timing for EMIFA Only†

TMS320C6414, TMS320C6415, TMS320C6416 FIXED-POINT DIGITAL SIGNAL PROCESSORS

SPRS146L – FEBRUARY 2001 – REVISED JULY 2004

HOLD/HOLDA TIMING

timing requirements for the $\overline{\text{HOLD}}/\overline{\text{HOLDA}}$ cycles for EMIFA and EMIFB modules† (see Figure 35)

| NO. | | -5E0 A-5E0 | | -6E3 A-6E3 -7E3 | | UNIT |
|-----|--|---------------|-----|-----------------------|-----|------|
| | | MIN | MAX | MIN | MAX | |
| 3 | $t_{\text{H}}(\overline{\text{HOLDAL}}-\overline{\text{HOLDL}})$ Hold time, $\overline{\text{HOLD}}$ low after $\overline{\text{HOLDA}}$ low | E | | E | | ns |

† E = the EMIF input clock (ECLKIN, CPU/4 clock, or CPU/6 clock) period in ns for EMIFA or EMIFB.

switching characteristics over recommended operating conditions for the $\overline{\text{HOLD}}/\overline{\text{HOLDA}}$ cycles for EMIFA and EMIFB modules†‡§ (see Figure 35)

| NO. | PARAMETER | | -5E0 A-5E0 | | -6E3 A-6E3 -7E3 | | UNIT |
|-----|---|--|---------------|-----|-----------------------|-----|------|
| | | | MIN | MAX | MIN | MAX | |
| 1 | $t_{\text{d}}(\overline{\text{HOLDL}}-\overline{\text{EMHZ}})$ | Delay time, $\overline{\text{HOLD}}$ low to EMIF Bus high impedance | 2E | † | 2E | † | ns |
| 2 | $t_{\text{d}}(\overline{\text{EMHZ}}-\overline{\text{HOLDAL}})$ | Delay time, EMIF Bus high impedance to $\overline{\text{HOLDA}}$ low | 0 | 2E | 0 | 2E | ns |
| 4 | $t_{\text{d}}(\overline{\text{HOLDH}}-\overline{\text{EMLZ}})$ | Delay time, $\overline{\text{HOLD}}$ high to EMIF Bus low impedance | 2E | 7E | 2E | 7E | ns |
| 5 | $t_{\text{d}}(\overline{\text{EMLZ}}-\overline{\text{HOLDAH}})$ | Delay time, EMIF Bus low impedance to $\overline{\text{HOLDA}}$ high | 0 | 2E | 0 | 2E | ns |
| 6 | $t_{\text{d}}(\overline{\text{HOLDL}}-\overline{\text{EKOHz}})$ | Delay time, $\overline{\text{HOLD}}$ low to ECLKOUTx high impedance | 2E | † | 2E | † | ns |
| 7 | $t_{\text{d}}(\overline{\text{HOLDH}}-\overline{\text{EKOHz}})$ | Delay time, $\overline{\text{HOLD}}$ high to ECLKOUTx low impedance | 2E | 7E | 2E | 7E | ns |

† E = the EMIF input clock (ECLKIN, CPU/4 clock, or CPU/6 clock) period in ns for EMIFA or EMIFB.

‡ For EMIFA, EMIF Bus consists of: $\overline{\text{ACE}}[3:0]$, $\overline{\text{ABE}}[7:0]$, $\overline{\text{AED}}[63:0]$, $\overline{\text{AEA}}[22:3]$, $\overline{\text{AARE}}/\overline{\text{ASDCAS}}/\overline{\text{ASADS}}/\overline{\text{ASRE}}$, $\overline{\text{AAOE}}/\overline{\text{ASDRAS}}/\overline{\text{ASOE}}$, and $\overline{\text{AAWE}}/\overline{\text{ASDWE}}/\overline{\text{ASWE}}$, $\overline{\text{ASDCKE}}$, $\overline{\text{ASOE3}}$, and $\overline{\text{APDT}}$.

For EMIFB, EMIF Bus consists of: $\overline{\text{BCE}}[3:0]$, $\overline{\text{BBE}}[1:0]$, $\overline{\text{BED}}[15:0]$, $\overline{\text{BEA}}[20:1]$, $\overline{\text{BARE}}/\overline{\text{BSDCAS}}/\overline{\text{BSADS}}/\overline{\text{BSRE}}$, $\overline{\text{BAOE}}/\overline{\text{BSDRAS}}/\overline{\text{BSOE}}$, and $\overline{\text{BAWE}}/\overline{\text{BSDWE}}/\overline{\text{BSWE}}$, $\overline{\text{BSOE3}}$, and $\overline{\text{BPDT}}$.

§ The EKxHZ bits in the EMIF Global Control register (GBLCTL) determine the state of the ECLKOUTx signals during $\overline{\text{HOLDA}}$. If EKxHZ = 0, ECLKOUTx continues clocking during Hold mode. If EKxHZ = 1, ECLKOUTx goes to high impedance during Hold mode, as shown in Figure 35.

† All pending EMIF transactions are allowed to complete before $\overline{\text{HOLDA}}$ is asserted. If no bus transactions are occurring, then the minimum delay time can be achieved. Also, bus hold can be indefinitely delayed by setting NOHOLD = 1.

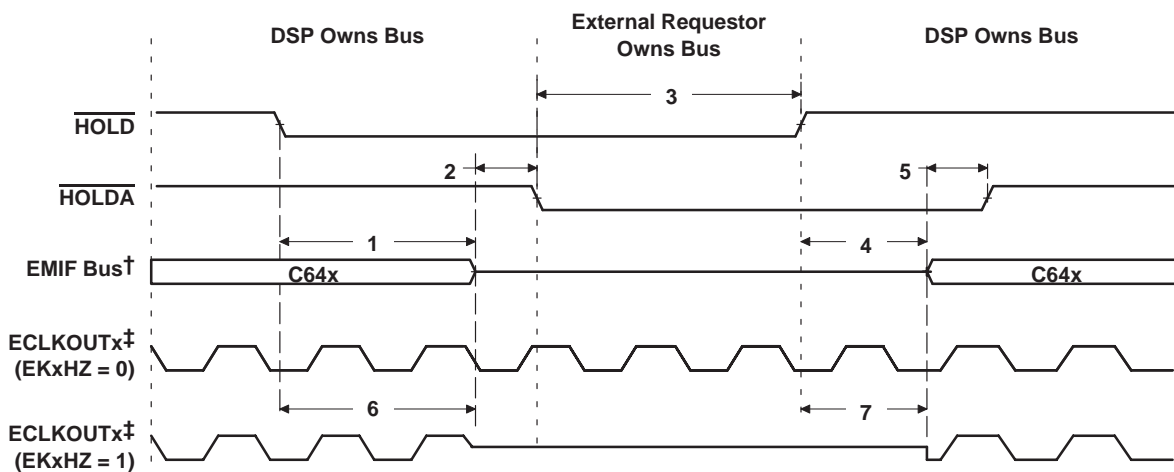

† For EMIFA, EMIF Bus consists of: $\overline{\text{ACE}}[3:0]$, $\overline{\text{ABE}}[7:0]$, $\overline{\text{AED}}[63:0]$, $\overline{\text{AEA}}[22:3]$, $\overline{\text{AARE}}/\overline{\text{ASDCAS}}/\overline{\text{ASADS}}/\overline{\text{ASRE}}$, $\overline{\text{AAOE}}/\overline{\text{ASDRAS}}/\overline{\text{ASOE}}$, and $\overline{\text{AAWE}}/\overline{\text{ASDWE}}/\overline{\text{ASWE}}$, $\overline{\text{ASDCKE}}$, $\overline{\text{ASOE3}}$, and $\overline{\text{APDT}}$.

For EMIFB, EMIF Bus consists of: $\overline{\text{BCE}}[3:0]$, $\overline{\text{BBE}}[1:0]$, $\overline{\text{BED}}[15:0]$, $\overline{\text{BEA}}[20:1]$, $\overline{\text{BARE}}/\overline{\text{BSDCAS}}/\overline{\text{BSADS}}/\overline{\text{BSRE}}$, $\overline{\text{BAOE}}/\overline{\text{BSDRAS}}/\overline{\text{BSOE}}$, and $\overline{\text{BAWE}}/\overline{\text{BSDWE}}/\overline{\text{BSWE}}$, $\overline{\text{BSOE3}}$, and $\overline{\text{BPDT}}$.

‡ The EKxHZ bits in the EMIF Global Control register (GBLCTL) determine the state of the ECLKOUTx signals during $\overline{\text{HOLDA}}$. If EKxHZ = 0, ECLKOUTx continues clocking during Hold mode. If EKxHZ = 1, ECLKOUTx goes to high impedance during Hold mode, as shown in Figure 35.

Figure 35. $\overline{\text{HOLD}}/\overline{\text{HOLDA}}$ Timing for EMIFA and EMIFB

ADVANCE INFORMATION



BUSREQ TIMING

switching characteristics over recommended operating conditions for the BUSREQ cycles for EMIFA and EMIFB modules (see Figure 36)

| NO. | PARAMETER | -5E0 A-5E0 | | -6E3 A-6E3 -7E3 | | UNIT |
|-----|---|---------------|-----|-----------------------|-----|------|
| | | MIN | MAX | MIN | MAX | |
| 1 | $t_d(\text{AEKO1H-ABUSRV})$ Delay time, AECLKOUTx high to ABUSREQ valid | 0.6 | 7.1 | 1 | 5.5 | ns |
| 2 | $t_d(\text{BEKO1H-BBUSRV})$ Delay time, BECLKOUTx high to BBUSREQ valid | 0.5 | 6.9 | 0.9 | 5.5 | ns |

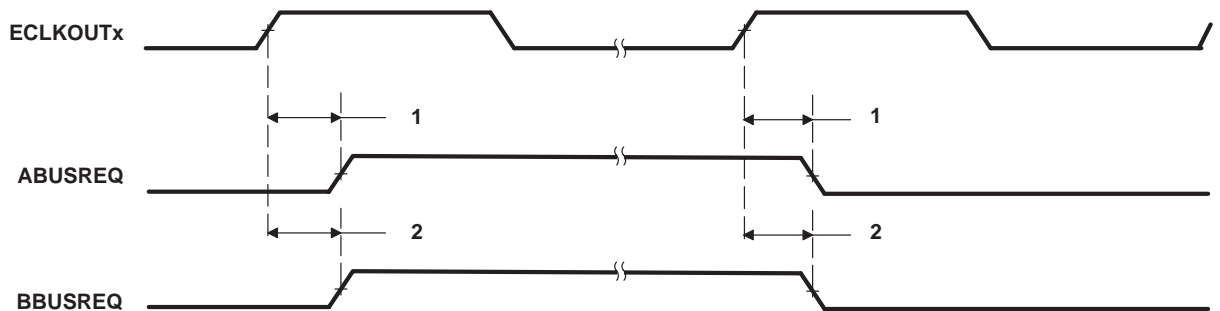

Figure 36. BUSREQ Timing for EMIFA and EMIFB

ADVANCE INFORMATION

TMS320C6414, TMS320C6415, TMS320C6416 FIXED-POINT DIGITAL SIGNAL PROCESSORS

SPRS146L – FEBRUARY 2001 – REVISED JULY 2004

RESET TIMING

timing requirements for reset† (see Figure 37)

| NO. | | | -5E0, A-5E0, -6E3, A-6E3, -7E3 | | UNIT |
|-----|-----------------------------|--|-----------------------------------|-----|------|
| | | | MIN | MAX | |
| 1 | t _w (RST) | Width of the $\overline{\text{RESET}}$ pulse (PLL stable)‡ | 10P | | ns |
| | | Width of the $\overline{\text{RESET}}$ pulse (PLL needs to sync up)§ | 250 | | µs |
| 16 | t _{su} (boot) | Setup time, boot configuration bits valid before $\overline{\text{RESET}}$ high¶ | 4E or 4C# | | ns |
| 17 | t _h (boot) | Hold time, boot configuration bits valid after $\overline{\text{RESET}}$ high¶ | 4P | | ns |
| 18 | t _{su} (PCLK-RSTH) | Setup time, PCLK active before $\overline{\text{RESET}}$ high | 32N | | ns |

† P = 1/CPU clock frequency in ns. For example, when running parts at 600 MHz, use P = 1.67 ns.

‡ This parameter applies to CLKMODE x1 when CLKIN is stable, and applies to CLKMODE x6, x12 when CLKIN and PLL are stable.

§ This parameter applies to CLKMODE x6, x12 only (it does not apply to CLKMODE x1). The $\overline{\text{RESET}}$ signal is not connected internally to the clock PLL circuit. The PLL, however, may need up to 250 µs to stabilize following device power up or after PLL configuration has been changed. During that time, $\overline{\text{RESET}}$ must be asserted to ensure proper device operation. See the *clock PLL* section for PLL lock times.

¶ EMIFB address pins BEA[20:13, 11, 7] are the boot configuration pins during device reset.

E = 1/AECLKIN clock frequency in ns. C = 1/CLKIN clock frequency in ns. Select whichever value is larger for the MIN parameter.

|| N = the PCI input clock (PCLK) period in ns. When PCI is enabled (PCI_EN = 1), this parameter *must* be met.

switching characteristics over recommended operating conditions during reset†*□ (see Figure 37)

| NO. | PARAMETER | | -5E0, A-5E0, -6E3, A-6E3, -7E3 | | UNIT |
|-----|-------------------------------|--|-----------------------------------|----------|------|
| | | | MIN | MAX | |
| 2 | t _d (RSTL-ECKI) | Delay time, $\overline{\text{RESET}}$ low to ECLKIN synchronized internally | 2E | 3P + 20E | ns |
| 3 | t _d (RSTH-ECKI) | Delay time, $\overline{\text{RESET}}$ high to ECLKIN synchronized internally | 2E | 8P + 20E | ns |
| 4 | t _d (RSTL-ECKO1HZ) | Delay time, $\overline{\text{RESET}}$ low to ECLKOUT1 high impedance | 2E | | ns |
| 5 | t _d (RSTH-ECKO1V) | Delay time, $\overline{\text{RESET}}$ high to ECLKOUT1 valid | 8P + 20E | | ns |
| 6 | t _d (RSTL-EMIFZHZ) | Delay time, $\overline{\text{RESET}}$ low to EMIF Z high impedance | 2E | 3P + 4E | ns |
| 7 | t _d (RSTH-EMIFZV) | Delay time, $\overline{\text{RESET}}$ high to EMIF Z valid | 16E | 8P + 20E | ns |
| 8 | t _d (RSTL-EMIFHIV) | Delay time, $\overline{\text{RESET}}$ low to EMIF high group invalid | 2E | | ns |
| 9 | t _d (RSTH-EMIFHV) | Delay time, $\overline{\text{RESET}}$ high to EMIF high group valid | 8P + 20E | | ns |
| 10 | t _d (RSTL-EMIFLIV) | Delay time, $\overline{\text{RESET}}$ low to EMIF low group invalid | 2E | | ns |
| 11 | t _d (RSTH-EMIFLV) | Delay time, $\overline{\text{RESET}}$ high to EMIF low group valid | 8P + 20E | | ns |
| 12 | t _d (RSTL-LOWIV) | Delay time, $\overline{\text{RESET}}$ low to low group invalid | 0 | | ns |
| 13 | t _d (RSTH-LOWV) | Delay time, $\overline{\text{RESET}}$ high to low group valid | 11P | | ns |
| 14 | t _d (RSTL-ZHZ) | Delay time, $\overline{\text{RESET}}$ low to Z group high impedance | 0 | | ns |
| 15 | t _d (RSTH-ZV) | Delay time, $\overline{\text{RESET}}$ high to Z group valid | 2P | 8P | ns |

† P = 1/CPU clock frequency in ns. For example, when running parts at 600 MHz, use P = 1.67 ns.

* E = the EMIF input clock (ECLKIN, CPU/4 clock, or CPU/6 clock) period in ns for EMIFA or EMIFB.

□ EMIF Z group consists of: AEA[22:3], BEA[20:1], AED[63:0], BED[15:0], CE[3:0], ABE[7:0], BBE[1:0], ARE/SDCAS/SADS/SRE, AWE/SDWE/SWE, and AOE/SDRAS/SOE, SOE3, ASDCKE, and PDT.

EMIF high group consists of: AHOLDA and BHOLDA (when the corresponding HOLD input is high)

EMIF low group consists of: ABUSREQ and BBUSREQ; AHOLDA and BHOLDA (when the corresponding HOLD input is low)

Low group consists of: XSP_CS, CLKX2/XSP_CLK, and DX2/XSP_DO; all of which apply only when PCI EEPROM (BEA13) is enabled (with PCI_EN = 1 and MCBSP2_EN = 0). Otherwise, the CLKX2/XSP_CLK and DX2/XSP_DO pins are in the Z group. For more details on the PCI configuration pins, see the Device Configurations section of this data sheet.

Z group consists of: HD[31:0]/AD[31:0], CLKX0, CLKX1/URADDR4, CLKX2/XSP_CLK, FSX0, FSX1/UXADDR3, FSX2, DX0, DX1/UXADDR4, DX2/XSP_DO, CLKR0, CLKR1/URADDR2, CLKR2, FSR0, FSR1/UXADDR2, FSR2, TOUT0, TOUT1, TOUT2, GP[8:0], GP10/PCBE3, HR/W/PCBE2, HDS2/PCBE1, PCBE0, GP13/PINTA, GP11/PREQ, HDS1/PSERR, HCS/PPERR, HCNTL1/PDEVSEL, HAS/PPAR, HCNTL0/PSTOP, HHWIL/PTRDY (16-bit HPI mode only), HRDY/PIRDY, HINT/PFRAME, UXDATA[7:0], UXSOC, UXCLAV, and URCLAV.

ADVANCE INFORMATION



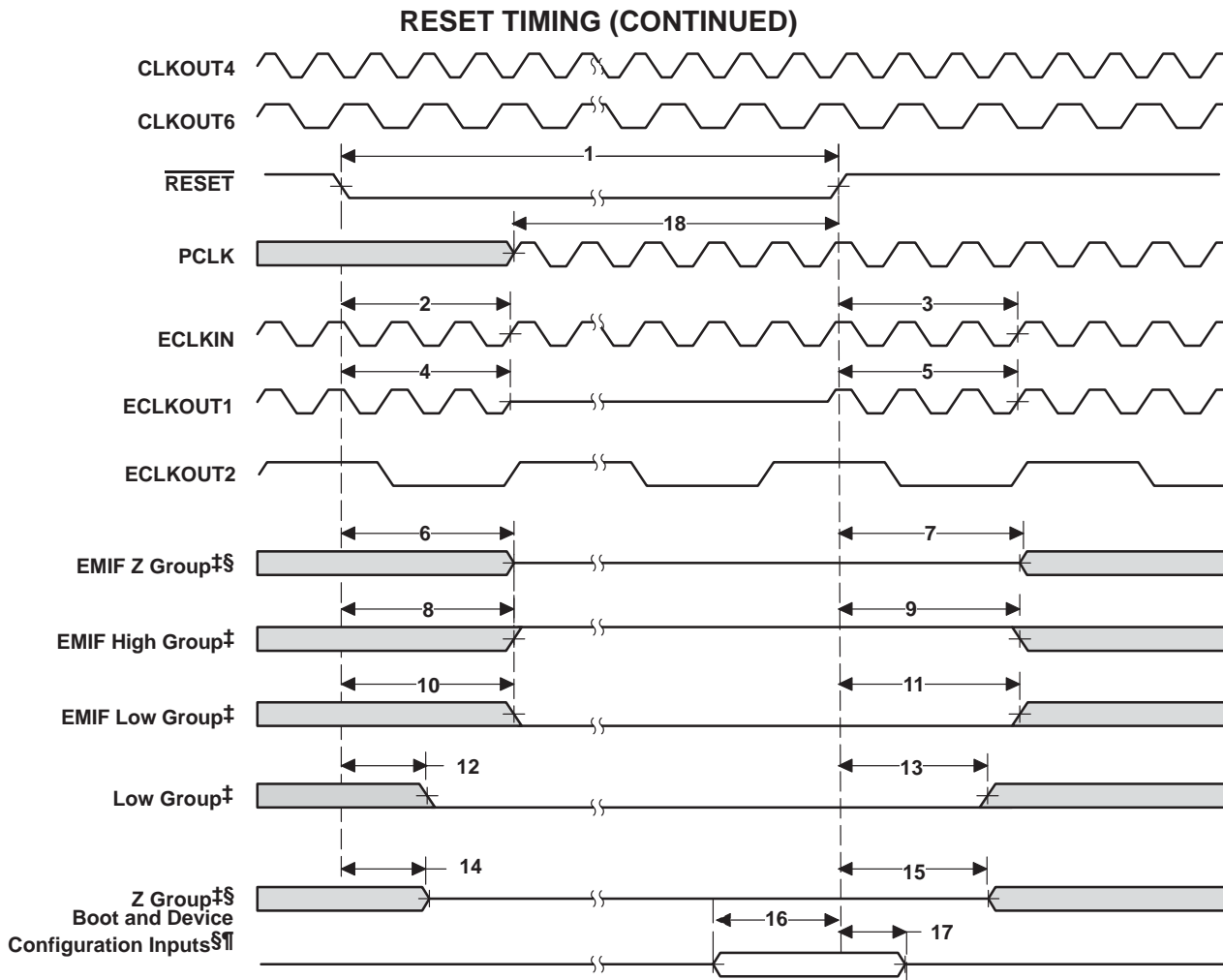

† These C64x™ devices have two EMIFs (EMIFA and EMIFB). All EMIFA signals are prefixed by an “A” and all EMIFB signals are prefixed by a “B”. Throughout the rest of this document, in generic EMIF areas of discussion, the prefix “A” or “B” may be omitted [e.g., ECLKIN, ECLKOUT1, and ECLKOUT2].

‡ EMIF Z group consists of: AEA[22:3], BEA[20:1], AED[63:0], BED[15:0], CE[3:0], ABE[7:0], BBE[1:0], ARE/SDCAS/SADS/SRE, AWE/SDWE/SWE, and AOE/SDRAS/SOE, SOE3, ASDCKE, and PDT.

EMIF high group consists of: AHOLDA and BHOLDA (when the corresponding HOLD input is high)

EMIF low group consists of: ABUSREQ and BBUSREQ; AHOLDA and BHOLDA (when the corresponding HOLD input is low)

Low group consists of: XSP_CS, CLKX2/XSP_CLK, and DX2/XSP_DO; all of which apply only when PCI EEPROM (BEA13) is enabled (with PCI_EN = 1 and MCBSP2_EN = 0). Otherwise, the CLKX2/XSP_CLK and DX2/XSP_DO pins are in the Z group. For more details on the PCI configuration pins, see the Device Configurations section of this data sheet.

Z group consists of: HD[31:0]/AD[31:0], CLKX0, CLKX1/URADDR4, CLKX2/XSP_CLK, FSX0, FSX1/UXADDR3, FSX2, DX0, DX1/UXADDR4, DX2/XSP_DO, CLKR0, CLKR1/URADDR2, CLKR2, FSR0, FSR1/UXADDR2, FSR2, TOUT0, TOUT1, TOUT2, GP[8:0], GP10/PCBE3, HR/W/PCBE2, HDS2/PCBE1, PCBE0, GP13/PINTA, GP11/PREQ, HDS1/PSERR, HCS/PPERR, HCNTL1/PDEVSEL, HAS/PPAR, HCNTL0/PSTOP, HHWIL/PTRDY (16-bit HPI mode only), HRDY/PIRDY, HINT/PFRAME, UXDATA[7:0], UXSOC, UXCLAV, and URCLAV.

§ If BEA[20:13, 11, 7] and HD5/AD5 pins are actively driven, care must be taken to ensure no timing contention between parameters 6, 7, 14, 15, 16, and 17.

¶ Boot and Device Configurations Inputs (during reset) include: EMIFB address pins BEA[20:13, 11, 7] and HD5/AD5.

The PCI_EN pin *must* be driven valid at all times and the user *must not* switch values throughout device operation.

The MCBSP2_EN pin *must* be driven valid at all times and the user *can* switch values throughout device operation.

Figure 37. Reset Timing†

EXTERNAL INTERRUPT TIMING

timing requirements for external interrupts† (see Figure 38)

| NO. | | | -5E0, A-5E0, -6E3, A-6E3, -7E3 | | UNIT |
|-----|--------------|---|--------------------------------------|-----|------|
| | | | MIN | MAX | |
| 1 | $t_w(ILOW)$ | Width of the NMI interrupt pulse low | 4P | | ns |
| | | Width of the EXT_INT interrupt pulse low | 8P | | ns |
| 2 | $t_w(IHIGH)$ | Width of the NMI interrupt pulse high | 4P | | ns |
| | | Width of the EXT_INT interrupt pulse high | 8P | | ns |

† P = 1/CPU clock frequency in ns. For example, when running parts at 600 MHz, use P = 1.67 ns.

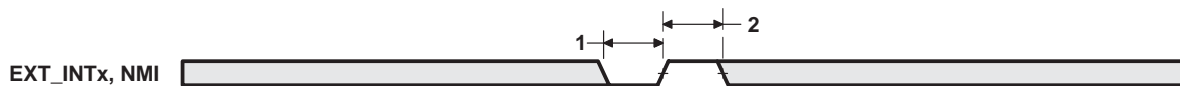

Figure 38. External/NMI Interrupt Timing

ADVANCE INFORMATION

HOST-PORT INTERFACE (HPI) TIMING

timing requirements for host-port interface cycles^{†‡} (see Figure 39 through Figure 46)

| NO. | | | -5E0, A-5E0, -6E3, A-6E3, -7E3 | | UNIT |
|-----|-----------------------------|--|--------------------------------------|-----|------|
| | | | MIN | MAX | |
| 1 | $t_{su}(\text{SELV-HSTBL})$ | Setup time, select signals [§] valid before $\overline{\text{HSTROBE}}$ low | 5 | | ns |
| 2 | $t_h(\text{HSTBL-SELV})$ | Hold time, select signals [§] valid after $\overline{\text{HSTROBE}}$ low | 2.4 | | ns |
| 3 | $t_w(\text{HSTBL})$ | Pulse duration, $\overline{\text{HSTROBE}}$ low | 4P [¶] | | ns |
| 4 | $t_w(\text{HSTBH})$ | Pulse duration, $\overline{\text{HSTROBE}}$ high between consecutive accesses | 4P | | ns |
| 10 | $t_{su}(\text{SELV-HASL})$ | Setup time, select signals [§] valid before $\overline{\text{HAS}}$ low | 5 | | ns |
| 11 | $t_h(\text{HASL-SELV})$ | Hold time, select signals [§] valid after $\overline{\text{HAS}}$ low | 2 | | ns |
| 12 | $t_{su}(\text{HDV-HSTBH})$ | Setup time, host data valid before $\overline{\text{HSTROBE}}$ high | 5 | | ns |
| 13 | $t_h(\text{HSTBH-HDV})$ | Hold time, host data valid after $\overline{\text{HSTROBE}}$ high | 2.8 | | ns |
| 14 | $t_h(\text{HRDYL-HSTBL})$ | Hold time, $\overline{\text{HSTROBE}}$ low after $\overline{\text{HRDY}}$ low. $\overline{\text{HSTROBE}}$ should not be inactivated until $\overline{\text{HRDY}}$ is active (low); otherwise, HPI writes will not complete properly. | 2 | | ns |
| 18 | $t_{su}(\text{HASL-HSTBL})$ | Setup time, $\overline{\text{HAS}}$ low before $\overline{\text{HSTROBE}}$ low | 2 | | ns |
| 19 | $t_h(\text{HSTBL-HASL})$ | Hold time, $\overline{\text{HAS}}$ low after $\overline{\text{HSTROBE}}$ low | 2.1 | | ns |

[†] $\overline{\text{HSTROBE}}$ refers to the following logical operation on $\overline{\text{HCS}}$, $\overline{\text{HDS1}}$, and $\overline{\text{HDS2}}$: $[\text{NOT}(\overline{\text{HDS1}} \text{ XOR } \overline{\text{HDS2}})] \text{ OR } \overline{\text{HCS}}$.

[‡] P = 1/CPU clock frequency in ns. For example, when running parts at 600 MHz, use P = 1.67 ns.

[§] Select signals include: $\overline{\text{HCNTL}}[1:0]$ and $\overline{\text{HR/W}}$. For HPI16 mode only, select signals also include $\overline{\text{HHWL}}$.

[¶] Select the parameter value of 4P or 12.5 ns, whichever is greater.

switching characteristics over recommended operating conditions during host-port interface cycles^{†‡} (see Figure 39 through Figure 46)

| NO. | PARAMETER | -5E0 -6E3 -7E3 | | A-5E0 A-6E3 | | UNIT |
|-----|---|----------------------|--------|----------------|--------|------|
| | | MIN | MAX | MIN | MAX | |
| 6 | $t_d(\text{HSTBL-HRDYH})$ Delay time, $\overline{\text{HSTROBE}}$ low to $\overline{\text{HRDY}}$ high [#] | 1.3 | 4P + 8 | 1.3 | 4P + 9 | ns |
| 7 | $t_d(\text{HSTBL-HDLZ})$ Delay time, $\overline{\text{HSTROBE}}$ low to HD low impedance for an HPI read | 2 | | 2 | | ns |
| 8 | $t_d(\text{HDV-HRDYL})$ Delay time, HD valid to $\overline{\text{HRDY}}$ low | -3 | | -3 | | ns |
| 9 | $t_{oh}(\text{HSTBH-HDV})$ Output hold time, HD valid after $\overline{\text{HSTROBE}}$ high | 1.5 | | 1.5 | | ns |
| 15 | $t_d(\text{HSTBH-HDHZ})$ Delay time, $\overline{\text{HSTROBE}}$ high to HD high impedance | | 12 | | 12 | ns |
| 16 | $t_d(\text{HSTBL-HDV})$ Delay time, $\overline{\text{HSTROBE}}$ low to HD valid (HPI16 mode, 2nd half-word only) | | 4P + 8 | | 4P + 8 | ns |

[†] $\overline{\text{HSTROBE}}$ refers to the following logical operation on $\overline{\text{HCS}}$, $\overline{\text{HDS1}}$, and $\overline{\text{HDS2}}$: $[\text{NOT}(\overline{\text{HDS1}} \text{ XOR } \overline{\text{HDS2}})] \text{ OR } \overline{\text{HCS}}$.

[‡] P = 1/CPU clock frequency in ns. For example, when running parts at 600 MHz, use P = 1.67 ns.

[#] This parameter is used during HPID reads and writes. For reads, at the beginning of a word transfer (HPI32) or the first half-word transfer (HPI16) on the falling edge of $\overline{\text{HSTROBE}}$, the HPI sends the request to the EDMA internal address generation hardware, and $\overline{\text{HRDY}}$ remains high until the EDMA internal address generation hardware loads the requested data into HPID. For writes, $\overline{\text{HRDY}}$ goes high if the internal write buffer is full.

HOST-PORT INTERFACE (HPI) TIMING (CONTINUED)

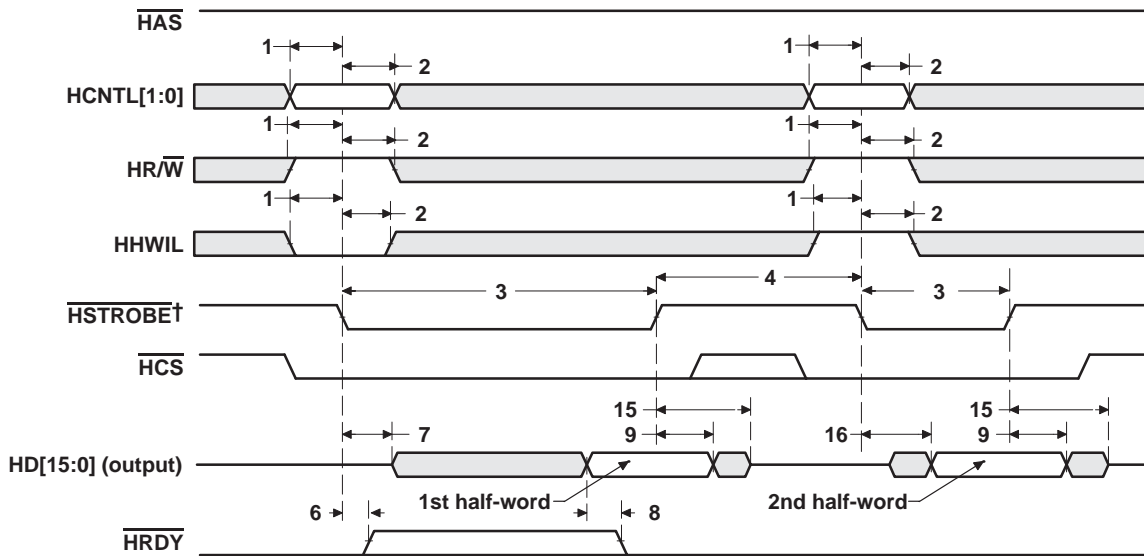

† HSTROBE refers to the following logical operation on HCS, HDS1, and HDS2: [NOT(HDS1 XOR HDS2)] OR HCS.

Figure 39. HPI16 Read Timing (HAS Not Used, Tied High)

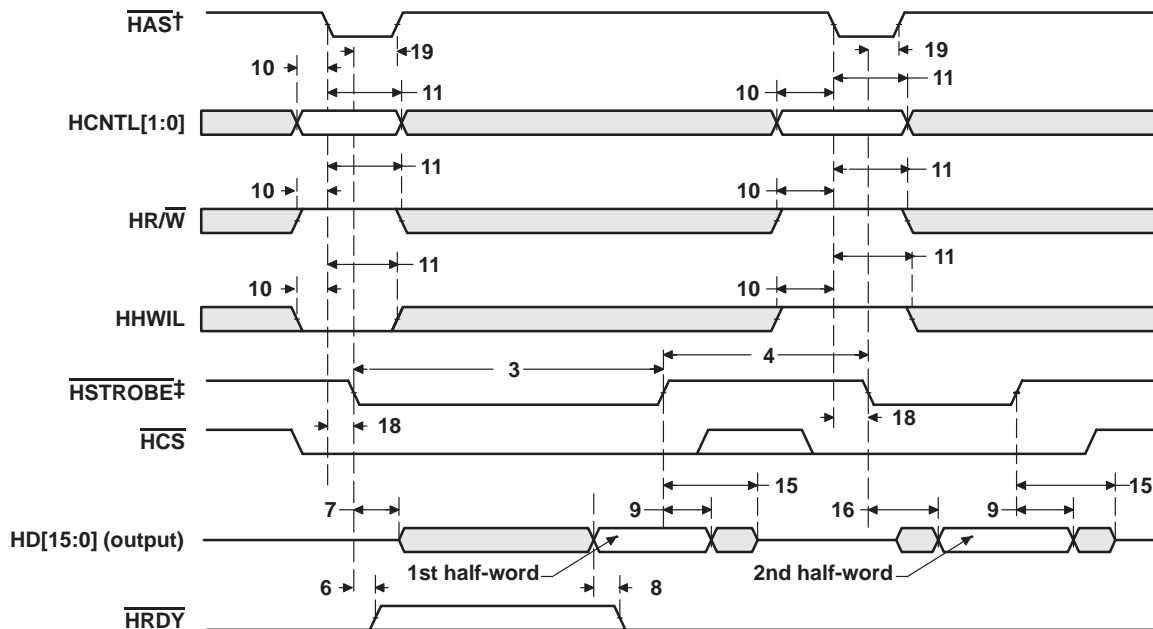

† For correct operation, strobe the HAS signal only once per HSTROBE active cycle.

‡ HSTROBE refers to the following logical operation on HCS, HDS1, and HDS2: [NOT(HDS1 XOR HDS2)] OR HCS.

Figure 40. HPI16 Read Timing (HAS Used)

HOST-PORT INTERFACE (HPI) TIMING (CONTINUED)

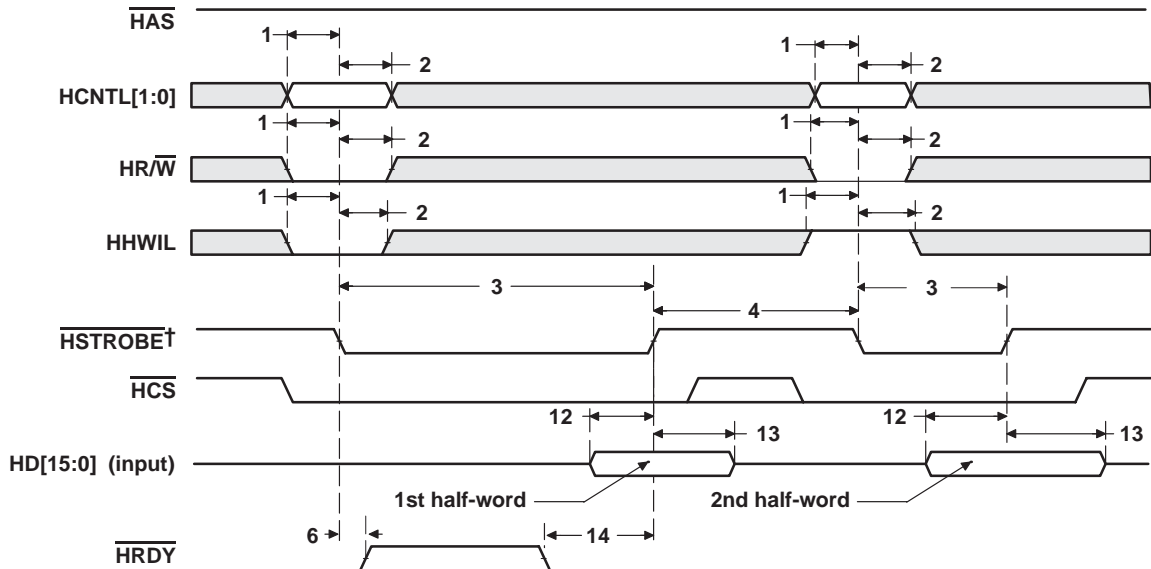

† HSTROBE refers to the following logical operation on $\overline{\text{HCS}}$, $\overline{\text{HDS1}}$, and $\overline{\text{HDS2}}$: $[\text{NOT}(\overline{\text{HDS1}} \text{ XOR } \overline{\text{HDS2}})] \text{ OR } \overline{\text{HCS}}$.

Figure 41. HPI16 Write Timing ($\overline{\text{HAS}}$ Not Used, Tied High)

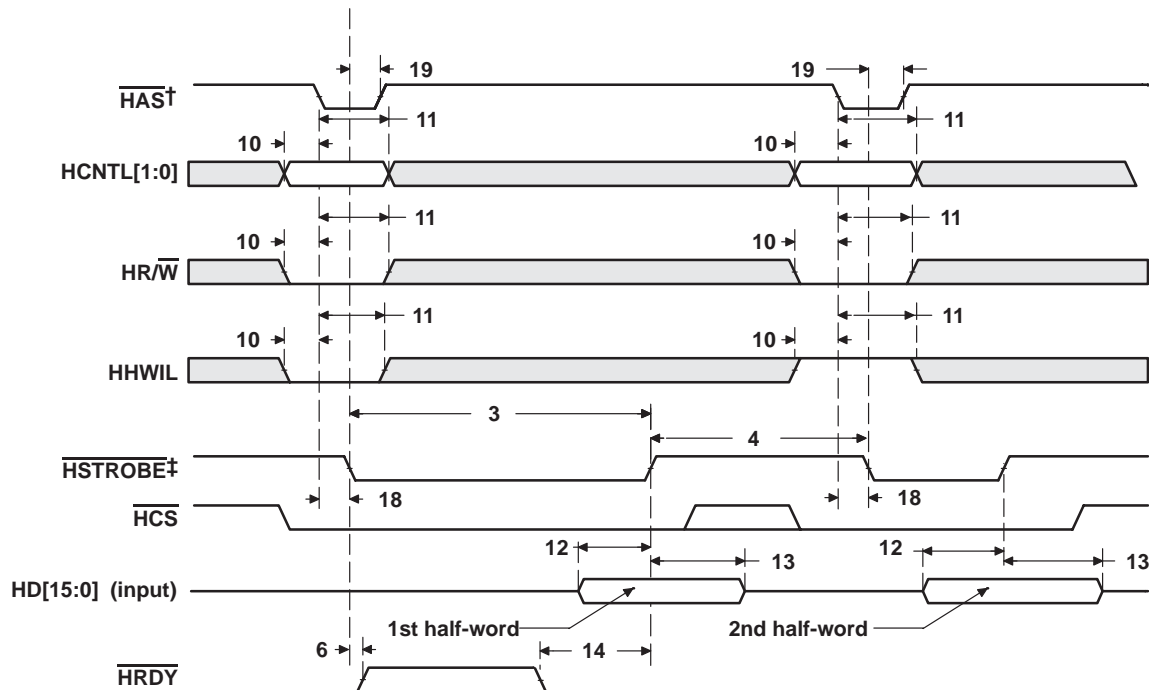

† For correct operation, strobe the $\overline{\text{HAS}}$ signal only once per HSTROBE active cycle.

‡ HSTROBE refers to the following logical operation on $\overline{\text{HCS}}$, $\overline{\text{HDS1}}$, and $\overline{\text{HDS2}}$: $[\text{NOT}(\overline{\text{HDS1}} \text{ XOR } \overline{\text{HDS2}})] \text{ OR } \overline{\text{HCS}}$.

Figure 42. HPI16 Write Timing ($\overline{\text{HAS}}$ Used)

HOST-PORT INTERFACE (HPI) TIMING (CONTINUED)

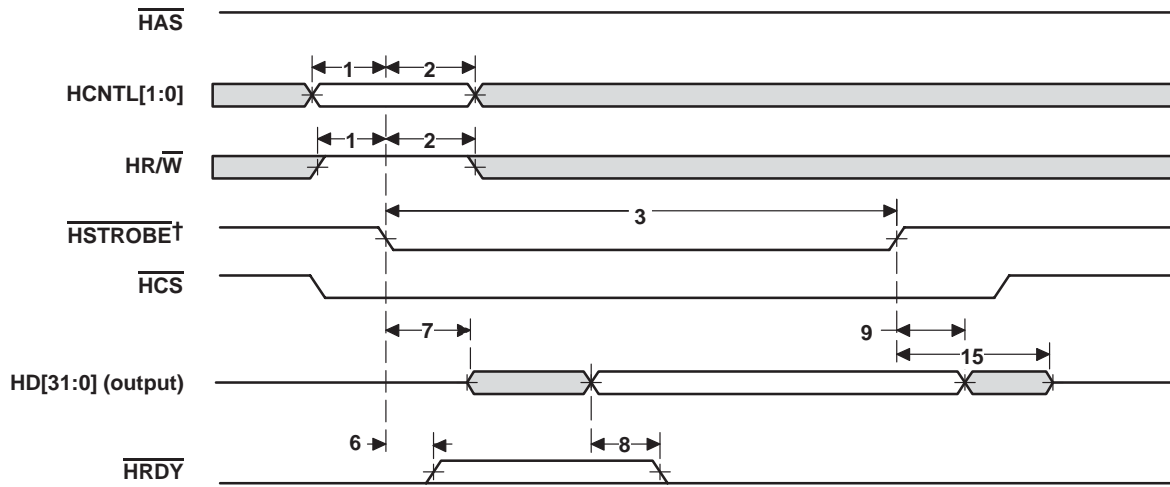

† $\overline{\text{HSTROBE}}$ refers to the following logical operation on $\overline{\text{HCS}}$, $\overline{\text{HDS1}}$, and $\overline{\text{HDS2}}$: $[\text{NOT}(\overline{\text{HDS1}} \text{ XOR } \overline{\text{HDS2}})] \text{ OR } \overline{\text{HCS}}$.

Figure 43. HPI32 Read Timing ($\overline{\text{HAS}}$ Not Used, Tied High)

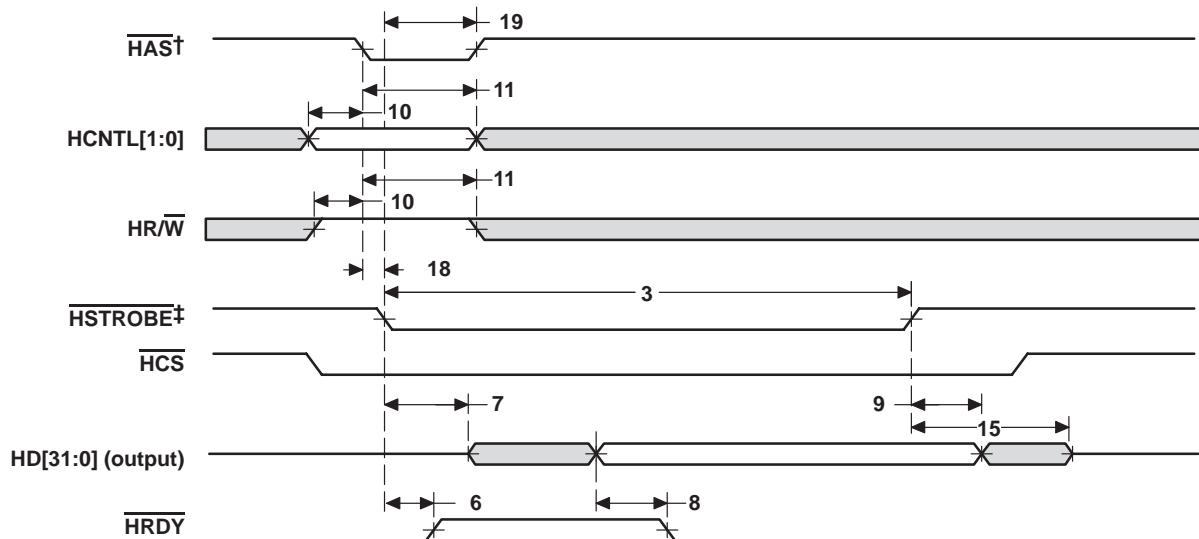

† For correct operation, strobe the $\overline{\text{HAS}}$ signal only once per $\overline{\text{HSTROBE}}$ active cycle.

‡ $\overline{\text{HSTROBE}}$ refers to the following logical operation on $\overline{\text{HCS}}$, $\overline{\text{HDS1}}$, and $\overline{\text{HDS2}}$: $[\text{NOT}(\overline{\text{HDS1}} \text{ XOR } \overline{\text{HDS2}})] \text{ OR } \overline{\text{HCS}}$.

Figure 44. HPI32 Read Timing ($\overline{\text{HAS}}$ Used)

HOST-PORT INTERFACE (HPI) TIMING (CONTINUED)

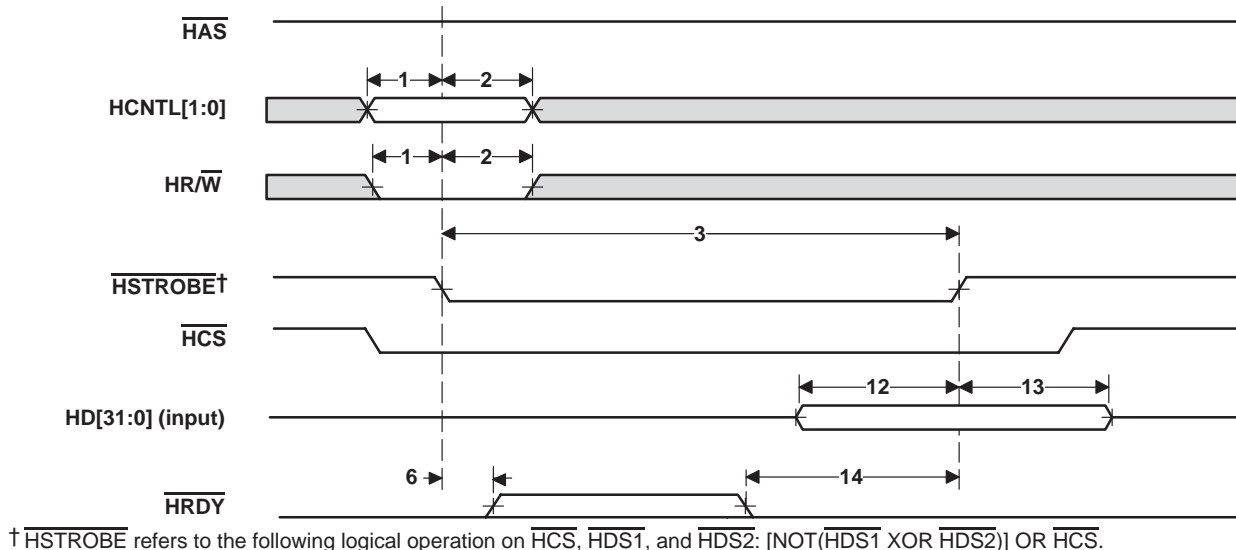

† $\overline{\text{HSTROBE}}$ refers to the following logical operation on $\overline{\text{HCS}}$, $\overline{\text{HDS1}}$, and $\overline{\text{HDS2}}$: $[\text{NOT}(\overline{\text{HDS1}} \text{ XOR } \overline{\text{HDS2}})] \text{ OR } \overline{\text{HCS}}$.

Figure 45. HPI32 Write Timing ($\overline{\text{HAS}}$ Not Used, Tied High)

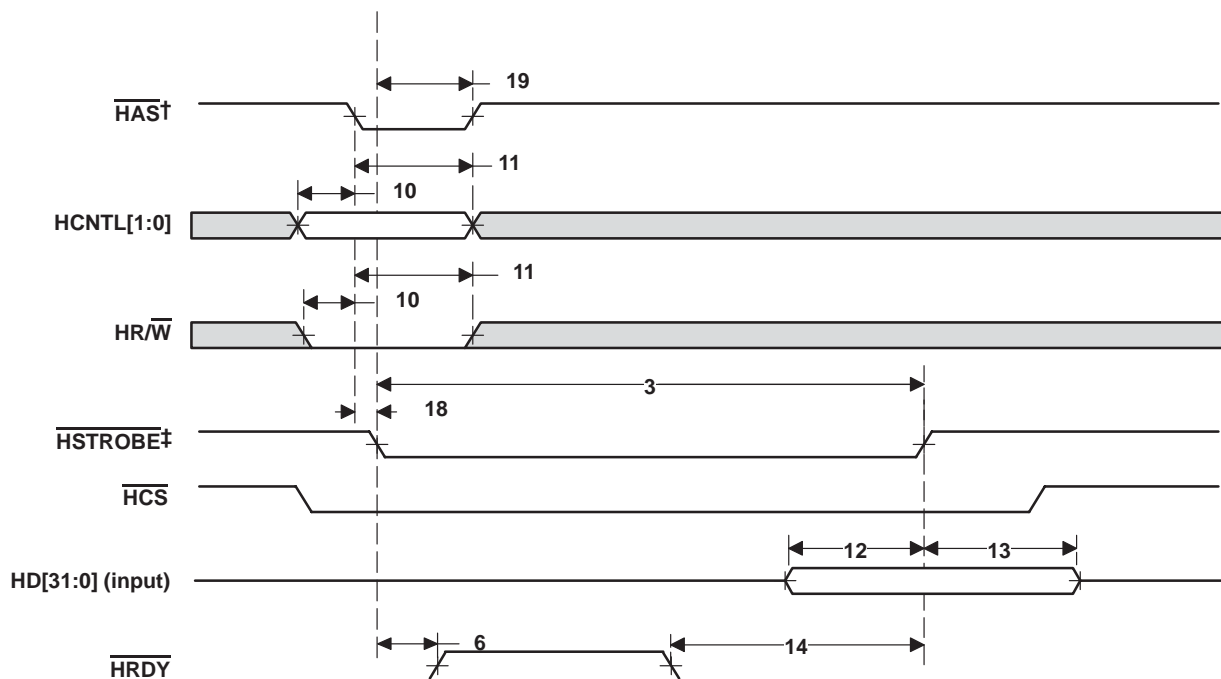

† For correct operation, strobe the $\overline{\text{HAS}}$ signal only once per $\overline{\text{HSTROBE}}$ active cycle.

‡ $\overline{\text{HSTROBE}}$ refers to the following logical operation on $\overline{\text{HCS}}$, $\overline{\text{HDS1}}$, and $\overline{\text{HDS2}}$: $[\text{NOT}(\overline{\text{HDS1}} \text{ XOR } \overline{\text{HDS2}})] \text{ OR } \overline{\text{HCS}}$.

Figure 46. HPI32 Write Timing ($\overline{\text{HAS}}$ Used)

TMS320C6414, TMS320C6415, TMS320C6416 FIXED-POINT DIGITAL SIGNAL PROCESSORS

SPRS146L – FEBRUARY 2001 – REVISED JULY 2004

PERIPHERAL COMPONENT INTERCONNECT (PCI) TIMING [C6415 AND C6416 ONLY]

timing requirements for PCLK†‡ (see Figure 47)

| NO. | | -5E0, A-5E0, -6E3, A-6E3, -7E3 | | UNIT |
|-----|---|--------------------------------------|-----|------|
| | | MIN | MAX | |
| 1 | $t_c(\text{PCLK})$ Cycle time, PCLK | 30 (or $8P^{\S}$) | | ns |
| 2 | $t_w(\text{PCLKH})$ Pulse duration, PCLK high | 11 | | ns |
| 3 | $t_w(\text{PCLKL})$ Pulse duration, PCLK low | 11 | | ns |
| 4 | $t_{sr}(\text{PCLK})$ $\Delta v/\Delta t$ slew rate, PCLK | 1 | 4 | V/ns |

† For 3.3-V operation, the reference points for the rise and fall transitions are measured at V_{ILP} MAX and V_{IHP} MIN.

‡ $P = 1/\text{CPU clock frequency}$ in ns. For example when running parts at 600 MHz, use $P = 1.67$ ns.

§ Select the parameter value of 30 ns or $8P$, whichever is greater.

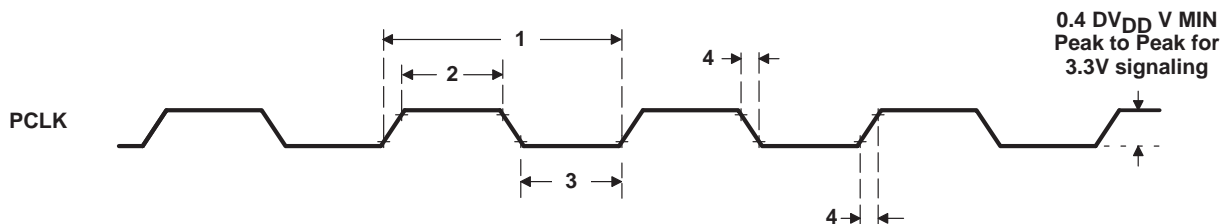

Figure 47. PCLK Timing

timing requirements for PCI reset (see Figure 48)

| NO. | | -5E0, A-5E0, -6E3, A-6E3, -7E3 | | UNIT |
|-----|---|--------------------------------------|-----|---------------|
| | | MIN | MAX | |
| 1 | $t_w(\overline{\text{PRST}})$ Pulse duration, $\overline{\text{PRST}}$ | 1 | | ms |
| 2 | $t_{su}(\text{PCLKA-PRSTH})$ Setup time, PCLK active before $\overline{\text{PRST}}$ high | 100 | | μs |

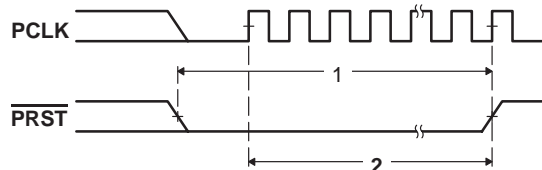

Figure 48. PCI Reset ($\overline{\text{PRST}}$) Timing

ADVANCE INFORMATION

PERIPHERAL COMPONENT INTERCONNECT (PCI) TIMING [C6415 AND C6416 ONLY]
(CONTINUED)

timing requirements for PCI inputs (see Figure 49)

| NO. | | | -5E0, A-5E0, -6E3, A-6E3, -7E3 | | UNIT |
|-----|--------------------|--|--------------------------------------|-----|------|
| | | | MIN | MAX | |
| 5 | $t_{su}(IV-PCLKH)$ | Setup time, input valid before PCLK high | 7 | | ns |
| 6 | $t_h(IV-PCLKH)$ | Hold time, input valid after PCLK high | 0 | | ns |

switching characteristics over recommended operating conditions for PCI outputs (see Figure 49)

| NO. | PARAMETER | | -5E0, A-5E0, -6E3, A-6E3, -7E3 | | UNIT |
|-----|------------------|--|--------------------------------------|-----|------|
| | | | MIN | MAX | |
| 1 | $t_d(PCLKH-OV)$ | Delay time, PCLK high to output valid | | 11 | ns |
| 2 | $t_d(PCLKH-OIV)$ | Delay time, PCLK high to output invalid | 2 | | ns |
| 3 | $t_d(PCLKH-OLZ)$ | Delay time, PCLK high to output low impedance | 2 | | ns |
| 4 | $t_d(PCLKH-OHZ)$ | Delay time, PCLK high to output high impedance | | 28 | ns |

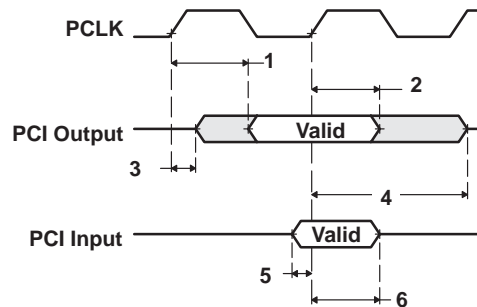

Figure 49. PCI Input/Output Timing

TMS320C6414, TMS320C6415, TMS320C6416 FIXED-POINT DIGITAL SIGNAL PROCESSORS

SPRS146L – FEBRUARY 2001 – REVISED JULY 2004

timing requirements for serial EEPROM interface (see Figure 50)

| NO. | | | -5E0, A-5E0, -6E3, A-6E3, -7E3 | | UNIT |
|-----|--------------------|--|--------------------------------------|-----|------|
| | | | MIN | MAX | |
| 8 | $t_{su}(DIV-CLKH)$ | Setup time, XSP_DI valid before XSP_CLK high | 50 | | ns |
| 9 | $t_h(CLKH-DIV)$ | Hold time, XSP_DI valid after XSP_CLK high | 0 | | ns |

switching characteristics over recommended operating conditions for serial EEPROM interface† (see Figure 50)

| NO. | PARAMETER | -5E0, A-5E0, -6E3, A-6E3, -7E3 | | | UNIT |
|-----|---------------------|---|-----|-------|------|
| | | MIN | TYP | MAX | |
| 1 | $t_w(CSL)$ | Pulse duration, XSP_CS low | | 4092P | ns |
| 2 | $t_d(CLKL-CSL)$ | Delay time, XSP_CLK low to XSP_CS low | | 0 | ns |
| 3 | $t_d(CSH-CLKH)$ | Delay time, XSP_CS high to XSP_CLK high | | 2046P | ns |
| 4 | $t_w(CLKH)$ | Pulse duration, XSP_CLK high | | 2046P | ns |
| 5 | $t_w(CLKL)$ | Pulse duration, XSP_CLK low | | 2046P | ns |
| 6 | $t_{osu}(DOV-CLKH)$ | Output setup time, XSP_DO valid before XSP_CLK high | | 2046P | ns |
| 7 | $t_{oh}(CLKH-DOV)$ | Output hold time, XSP_DO valid after XSP_CLK high | | 2046P | ns |

† P = 1/CPU clock frequency in ns. For example, when running parts at 600 MHz, use P = 1.67 ns.

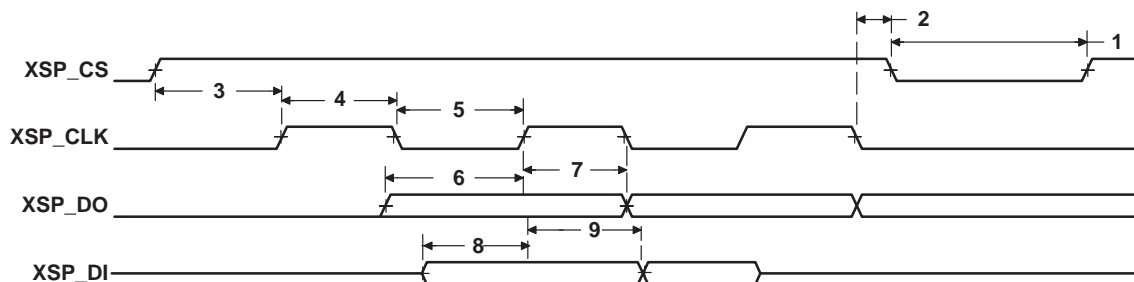

Figure 50. PCI Serial EEPROM Interface Timing

ADVANCE INFORMATION

MULTICHANNEL BUFFERED SERIAL PORT (McBSP) TIMING

timing requirements for McBSP[†] (see Figure 51)

| NO. | | | | -5E0, A-5E0, -6E3, A-6E3, -7E3 | | UNIT |
|-----|----------------------------|---|------------|---|-----|------|
| | | | | MIN | MAX | |
| 2 | t _c (CKRX) | Cycle time, CLKR/X | CLKR/X ext | 4P or 6.67 [‡] §¶ | | ns |
| 3 | t _w (CKRX) | Pulse duration, CLKR/X high or CLKR/X low | CLKR/X ext | 0.5t _c (CKRX) – 1 [#] | | ns |
| 5 | t _{su} (FRH-CKRL) | Setup time, external FSR high before CLKR low | CLKR int | 9 | | ns |
| | | | CLKR ext | 1.3 | | |
| 6 | t _h (CKRL-FRH) | Hold time, external FSR high after CLKR low | CLKR int | 6 | | ns |
| | | | CLKR ext | 3 | | |
| 7 | t _{su} (DRV-CKRL) | Setup time, DR valid before CLKR low | CLKR int | 8 | | ns |
| | | | CLKR ext | 0.9 | | |
| 8 | t _h (CKRL-DRV) | Hold time, DR valid after CLKR low | CLKR int | 3 | | ns |
| | | | CLKR ext | 3.1 | | |
| 10 | t _{su} (FXH-CKXL) | Setup time, external FSX high before CLKX low | CLKX int | 9 | | ns |
| | | | CLKX ext | 1.3 | | |
| 11 | t _h (CKXL-FXH) | Hold time, external FSX high after CLKX low | CLKX int | 6 | | ns |
| | | | CLKX ext | 3 | | |

[†] CLKRP = CLKXP = FSRP = FSXP = 0. If polarity of any of the signals is inverted, then the timing references of that signal are also inverted.
[‡] Minimum CLKR/X cycle times *must* be met, even when CLKR/X is generated by an internal clock source. Minimum CLKR/X cycle times are based on internal logic speed; the maximum usable speed may be lower due to EDMA limitations and AC timing requirements.
[§] P = 1/CPU clock frequency in ns. For example, when running parts at 600 MHz, use P = 1.67 ns.
[¶] Use whichever value is greater.
[#] This parameter applies to the maximum McBSP frequency. Operate serial clocks (CLKR/X) in the reasonable range of 40/60 duty cycle.

ADVANCE INFORMATION

TMS320C6414, TMS320C6415, TMS320C6416 FIXED-POINT DIGITAL SIGNAL PROCESSORS

SPRS146L – FEBRUARY 2001 – REVISED JULY 2004

MULTICHANNEL BUFFERED SERIAL PORT (McBSP) TIMING (CONTINUED)

switching characteristics over recommended operating conditions for McBSP^{†‡} (see Figure 51)

| NO. | PARAMETER | -5E0, A-5E0, -6E3, A-6E3, -7E3 | | UNIT |
|-----|--|--|--------------------|------|
| | | MIN | MAX | |
| 1 | $t_d(\text{CKSH-CKRXH})$ Delay time, CLKS high to CLKR/X high for internal CLKR/X generated from CLKS input | 1.4 | 10 | ns |
| 2 | $t_c(\text{CKRX})$ Cycle time, CLKR/X | CLKR/X int 4P or 6.67 $\frac{S}{\#}$ | | ns |
| 3 | $t_w(\text{CKRX})$ Pulse duration, CLKR/X high or CLKR/X low | CLKR/X int C - 1 \parallel C + 1 \parallel | | ns |
| 4 | $t_d(\text{CKRH-FRV})$ Delay time, CLKR high to internal FSR valid | CLKR int -2.1 | 3 | ns |
| 9 | $t_d(\text{CKXH-FXV})$ Delay time, CLKX high to internal FSX valid | CLKX int -1.7 | 3 | ns |
| | | CLKX ext 1.7 | 9 | |
| 12 | $t_{dis}(\text{CKXH-DXHZ})$ Disable time, DX high impedance following last data bit from CLKX high | CLKX int -3.9 | 4 | ns |
| | | CLKX ext 2.0 | 9 | |
| 13 | $t_d(\text{CKXH-DXV})$ Delay time, CLKX high to DX valid | CLKX int -3.9 + D1 \star | 4 + D2 \star | ns |
| | | CLKX ext 2.0 + D1 \star | 9 + D2 \star | |
| 14 | $t_d(\text{FXH-DXV})$ Delay time, FSX high to DX valid ONLY applies when in data delay 0 (XDATDLY = 00b) mode | FSX int -2.3 + D1 \square | 5.6 + D2 \square | ns |
| | | FSX ext 1.9 + D1 \square | 9 + D2 \square | |

[†] CLKRP = CLKXP = FSRP = FSXP = 0. If polarity of any of the signals is inverted, then the timing references of that signal are also inverted.

[‡] Minimum delay times also represent minimum output hold times.

[§] Minimum CLKR/X cycle times must be met, even when CLKR/X is generated by an internal clock source. Minimum CLKR/X cycle times are based on internal logic speed; the maximum usable speed may be lower due to EDMA limitations and AC timing requirements.

[¶] P = 1/CPU clock frequency in ns. For example, when running parts at 600 MHz, use P = 1.67 ns.

[#] Use whichever value is greater.

^{||} C = H or L

S = sample rate generator input clock = 4P if CLKSM = 1 (P = 1/CPU clock frequency)

= sample rate generator input clock = P_clks if CLKSM = 0 (P_clks = CLKS period)

H = CLKX high pulse width = (CLKGDV/2 + 1) * S if CLKGDV is even

= (CLKGDV + 1)/2 * S if CLKGDV is odd or zero

L = CLKX low pulse width = (CLKGDV/2) * S if CLKGDV is even

= (CLKGDV + 1)/2 * S if CLKGDV is odd or zero

CLKGDV should be set appropriately to ensure the McBSP bit rate does not exceed the maximum limit (see [¶] footnote above).

^{*} Extra delay from CLKX high to DX valid **applies only to the first data bit of a device**, if and only if DXENA = 1 in SPCR.

if DXENA = 0, then D1 = D2 = 0

if DXENA = 1, then D1 = 4P, D2 = 8P

[□] Extra delay from FSX high to DX valid **applies only to the first data bit of a device**, if and only if DXENA = 1 in SPCR.

if DXENA = 0, then D1 = D2 = 0

if DXENA = 1, then D1 = 4P, D2 = 8P

ADVANCE INFORMATION



MULTICHANNEL BUFFERED SERIAL PORT (McBSP) TIMING (CONTINUED)

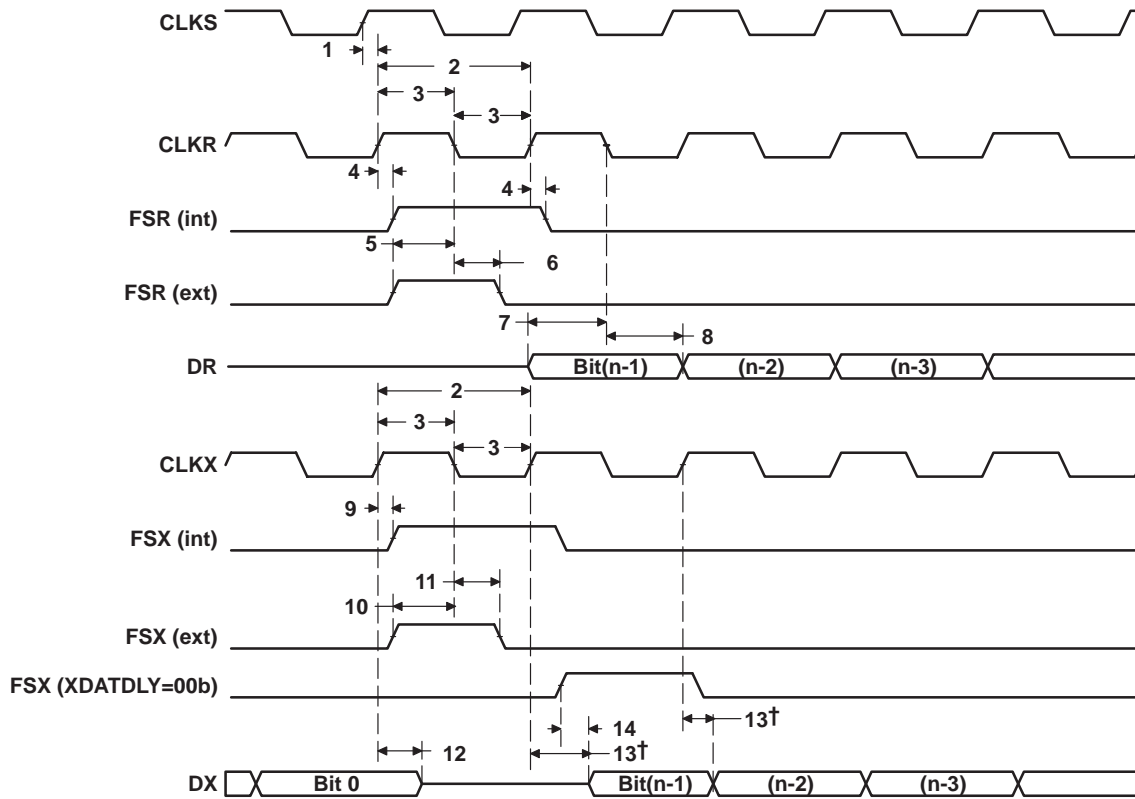

† Parameter No. 13 applies to the first data bit *only* when XDATDLY ≠ 0

Figure 51. McBSP Timing

MULTICHANNEL BUFFERED SERIAL PORT (McBSP) TIMING (CONTINUED)

timing requirements for FSR when GSYNC = 1 (see Figure 52)

| NO. | | -5E0, A-5E0, -6E3, A-6E3, -7E3 | | UNIT |
|-----|--|--------------------------------------|-----|------|
| | | MIN | MAX | |
| 1 | $t_{su}(FRH-CKSH)$ Setup time, FSR high before CLKS high | 4 | | ns |
| 2 | $t_h(CKSH-FRH)$ Hold time, FSR high after CLKS high | 4 | | ns |

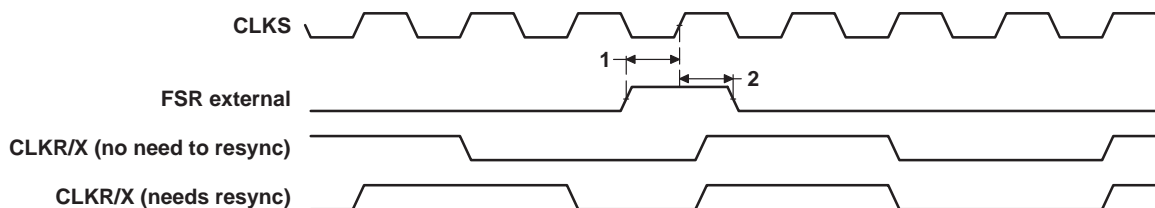

Figure 52. FSR Timing When GSYNC = 1

ADVANCE INFORMATION

MULTICHANNEL BUFFERED SERIAL PORT (McBSP) TIMING (CONTINUED)

timing requirements for McBSP as SPI Master or Slave: CLKSTP = 10b, CLKXP = 0†‡ (see Figure 53)

| NO. | | -5E0, A-5E0, -6E3, A-6E3, -7E3 | | | | UNIT |
|-----|---|--------------------------------------|-----|---------|-----|------|
| | | MASTER | | SLAVE | | |
| | | MIN | MAX | MIN | MAX | |
| 4 | t _{su} (DRV-CKXL) Setup time, DR valid before CLKX low | 12 | | 2 – 12P | ns | |
| 5 | t _h (CKXL-DRV) Hold time, DR valid after CLKX low | 4 | | 5 + 24P | ns | |

† P = 1/CPU clock frequency in ns. For example, when running parts at 600 MHz, use P = 1.67 ns.

‡ For all SPI Slave modes, CLKG is programmed as 1/4 of the CPU clock by setting CLKSM = CLKGDV = 1.

switching characteristics over recommended operating conditions for McBSP as SPI Master or Slave: CLKSTP = 10b, CLKXP = 0†‡ (see Figure 53)

| NO. | PARAMETER | -5E0, A-5E0, -6E3, A-6E3, -7E3 | | | | UNIT |
|-----|--|--------------------------------------|-------|--------------------|-----|------|
| | | MASTER§ | | SLAVE | | |
| | | MIN | MAX | MIN | MAX | |
| 1 | t _h (CKXL-FXL) Hold time, FSX low after CLKX low¶ | T – 2 | T + 3 | | ns | |
| 2 | t _d (FXL-CKXH) Delay time, FSX low to CLKX high# | L – 2 | L + 3 | | ns | |
| 3 | t _d (CKXH-DXV) Delay time, CLKX high to DX valid | –2 | 4 | 12P + 2.8 20P + 17 | ns | |
| 6 | t _{dis} (CKXL-DXHZ) Disable time, DX high impedance following last data bit from CLKX low | L – 2 | L + 3 | | ns | |
| 7 | t _{dis} (FXH-DXHZ) Disable time, DX high impedance following last data bit from FSX high | | | 4P + 3 12P + 17 | ns | |
| 8 | t _d (FXL-DXV) Delay time, FSX low to DX valid | | | 8P + 1.8 16P + 17 | ns | |

† P = 1/CPU clock frequency in ns. For example, when running parts at 600 MHz, use P = 1.67 ns.

‡ For all SPI Slave modes, CLKG is programmed as 1/4 of the CPU clock by setting CLKSM = CLKGDV = 1.

§ S = Sample rate generator input clock = 4P if CLKSM = 1 (P = 1/CPU clock frequency)

= Sample rate generator input clock = P_clks if CLKSM = 0 (P_clks = CLK period)

T = CLKX period = (1 + CLKGDV) * S

H = CLKX high pulse width = (CLKGDV/2 + 1) * S if CLKGDV is even
= (CLKGDV + 1)/2 * S if CLKGDV is odd or zero

L = CLKX low pulse width = (CLKGDV/2) * S if CLKGDV is even
= (CLKGDV + 1)/2 * S if CLKGDV is odd or zero

¶ FSRP = FSXP = 1. As a SPI Master, FSX is inverted to provide active-low slave-enable output. As a Slave, the active-low signal input on FSX and FSR is inverted before being used internally.

CLKXM = FSXM = 1, CLKRM = FSRM = 0 for Master McBSP

CLKXM = CLKRM = FSXM = FSRM = 0 for Slave McBSP

FSX should be low before the rising edge of clock to enable Slave devices and then begin a SPI transfer at the rising edge of the Master clock (CLKX).

ADVANCE INFORMATION

MULTICHANNEL BUFFERED SERIAL PORT (McBSP) TIMING (CONTINUED)

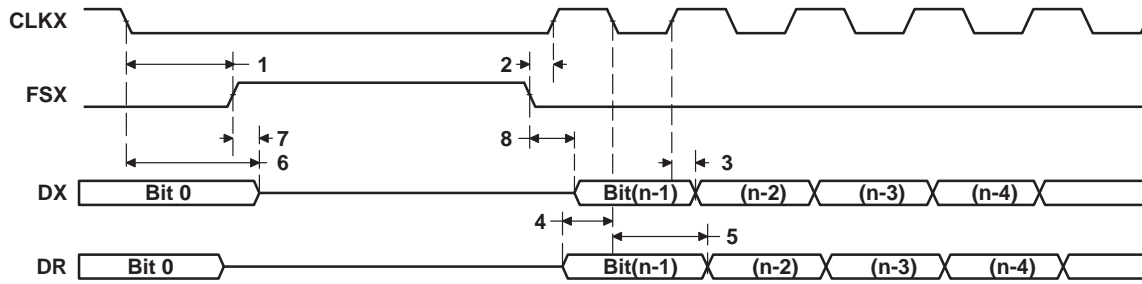

Figure 53. McBSP Timing as SPI Master or Slave: CLKSTP = 10b, CLKXP = 0

MULTICHANNEL BUFFERED SERIAL PORT (McBSP) TIMING (CONTINUED)

timing requirements for McBSP as SPI Master or Slave: CLKSTP = 11b, CLKXP = 0†‡ (see Figure 54)

| NO. | | -5E0, A-5E0, -6E3, A-6E3, -7E3 | | | | UNIT |
|-----|--|--------------------------------------|-----|---------|-----|------|
| | | MASTER | | SLAVE | | |
| | | MIN | MAX | MIN | MAX | |
| 4 | t _{su} (DRV-CKXH) Setup time, DR valid before CLKX high | 12 | | 2 – 12P | ns | |
| 5 | t _h (CKXH-DRV) Hold time, DR valid after CLKX high | 4 | | 5 + 24P | ns | |

† P = 1/CPU clock frequency in ns. For example, when running parts at 600 MHz, use P = 1.67 ns.

‡ For all SPI Slave modes, CLKG is programmed as 1/4 of the CPU clock by setting CLKSM = CLKGDV = 1.

switching characteristics over recommended operating conditions for McBSP as SPI Master or Slave: CLKSTP = 11b, CLKXP = 0†‡ (see Figure 54)

| NO. | PARAMETER | -5E0, A-5E0, -6E3, A-6E3, -7E3 | | | | UNIT |
|-----|--|--------------------------------------|-------|---------|----------|------|
| | | MASTER§ | | SLAVE | | |
| | | MIN | MAX | MIN | MAX | |
| 1 | t _h (CKXL-FXL) Hold time, FSX low after CLKX low¶ | L – 2 | L + 3 | | | ns |
| 2 | t _d (FXL-CKXH) Delay time, FSX low to CLKX high# | T – 2 | T + 3 | | | ns |
| 3 | t _d (CKXL-DXV) Delay time, CLKX low to DX valid | -2 | 4 | 12P + 4 | 20P + 17 | ns |
| 6 | t _{dis} (CKXL-DXHZ) Disable time, DX high impedance following last data bit from CLKX low | -2 | 4 | 12P + 3 | 20P + 17 | ns |
| 7 | t _d (FXL-DXV) Delay time, FSX low to DX valid | H – 2 | H + 4 | 8P + 2 | 16P + 17 | ns |

† P = 1/CPU clock frequency in ns. For example, when running parts at 600 MHz, use P = 1.67 ns.

‡ For all SPI Slave modes, CLKG is programmed as 1/4 of the CPU clock by setting CLKSM = CLKGDV = 1.

§ S = Sample rate generator input clock = 4P if CLKSM = 1 (P = 1/CPU clock frequency)

= Sample rate generator input clock = P_clks if CLKSM = 0 (P_clks = CLKS period)

T = CLKX period = (1 + CLKGDV) * S

H = CLKX high pulse width = (CLKGDV/2 + 1) * S if CLKGDV is even
= (CLKGDV + 1)/2 * S if CLKGDV is odd or zero

L = CLKX low pulse width = (CLKGDV/2) * S if CLKGDV is even
= (CLKGDV + 1)/2 * S if CLKGDV is odd or zero

¶ FSRP = FSXP = 1. As a SPI Master, FSX is inverted to provide active-low slave-enable output. As a Slave, the active-low signal input on FSX and FSR is inverted before being used internally.

CLKXM = FSXM = 1, CLKRM = FSRM = 0 for Master McBSP

CLKXM = CLKRM = FSXM = FSRM = 0 for Slave McBSP

FSX should be low before the rising edge of clock to enable Slave devices and then begin a SPI transfer at the rising edge of the Master clock (CLKX).

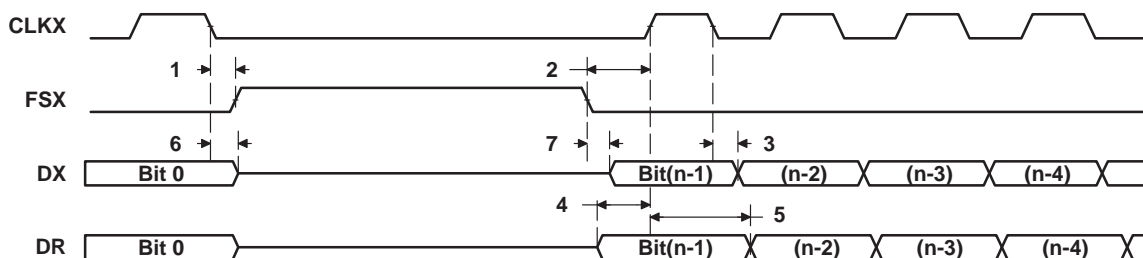

Figure 54. McBSP Timing as SPI Master or Slave: CLKSTP = 11b, CLKXP = 0

ADVANCE INFORMATION

TMS320C6414, TMS320C6415, TMS320C6416 FIXED-POINT DIGITAL SIGNAL PROCESSORS

SPRS146L – FEBRUARY 2001 – REVISED JULY 2004

MULTICHANNEL BUFFERED SERIAL PORT (McBSP) TIMING (CONTINUED)

timing requirements for McBSP as SPI Master or Slave: CLKSTP = 10b, CLKXP = 1†‡ (see Figure 55)

| NO. | | -5E0, A-5E0, -6E3, A-6E3, -7E3 | | | | UNIT |
|-----|--|--------------------------------------|-----|---------|-----|------|
| | | MASTER | | SLAVE | | |
| | | MIN | MAX | MIN | MAX | |
| 4 | t _{su} (DRV-CKXH) Setup time, DR valid before CLKX high | 12 | | 2 – 12P | ns | |
| 5 | t _h (CKXH-DRV) Hold time, DR valid after CLKX high | 4 | | 5 + 24P | ns | |

† P = 1/CPU clock frequency in ns. For example, when running parts at 600 MHz, use P = 1.67 ns.

‡ For all SPI Slave modes, CLKG is programmed as 1/4 of the CPU clock by setting CLKSM = CLKGDV = 1.

switching characteristics over recommended operating conditions for McBSP as SPI Master or Slave: CLKSTP = 10b, CLKXP = 1†‡ (see Figure 55)

| NO. | PARAMETER | -5E0, A-5E0, -6E3, A-6E3, -7E3 | | | | UNIT |
|-----|---|--------------------------------------|-------|------------------|-----|------|
| | | MASTER§ | | SLAVE | | |
| | | MIN | MAX | MIN | MAX | |
| 1 | t _h (CKXH-FXL) Hold time, FSX low after CLKX high¶ | T – 2 | T + 3 | | ns | |
| 2 | t _d (FXL-CKXL) Delay time, FSX low to CLKX low# | H – 2 | H + 3 | | ns | |
| 3 | t _d (CKXL-DXV) Delay time, CLKX low to DX valid | -2 | 4 | 12P + 4 20P + 17 | ns | |
| 6 | t _{dis} (CKXH-DXHZ) Disable time, DX high impedance following last data bit from CLKX high | H – 2 | H + 3 | | ns | |
| 7 | t _{dis} (FXH-DXHZ) Disable time, DX high impedance following last data bit from FSX high | | | 4P + 3 12P + 17 | ns | |
| 8 | t _d (FXL-DXV) Delay time, FSX low to DX valid | | | 8P + 2 16P + 17 | ns | |

† P = 1/CPU clock frequency in ns. For example, when running parts at 600 MHz, use P = 1.67 ns.

‡ For all SPI Slave modes, CLKG is programmed as 1/4 of the CPU clock by setting CLKSM = CLKGDV = 1.

§ S = Sample rate generator input clock = 4P if CLKSM = 1 (P = 1/CPU clock frequency)

= Sample rate generator input clock = P_clks if CLKSM = 0 (P_clks = CLKS period)

T = CLKX period = (1 + CLKGDV) * S

H = CLKX high pulse width = (CLKGDV/2 + 1) * S if CLKGDV is even
= (CLKGDV + 1)/2 * S if CLKGDV is odd or zero

L = CLKX low pulse width = (CLKGDV/2) * S if CLKGDV is even
= (CLKGDV + 1)/2 * S if CLKGDV is odd or zero

¶ FSRP = FSXP = 1. As a SPI Master, FSX is inverted to provide active-low slave-enable output. As a Slave, the active-low signal input on FSX and FSR is inverted before being used internally.

CLKXM = FSXM = 1, CLKRM = FSRM = 0 for Master McBSP

CLKXM = CLKRM = FSXM = FSRM = 0 for Slave McBSP

FSX should be low before the rising edge of clock to enable Slave devices and then begin a SPI transfer at the rising edge of the Master clock (CLKX).

ADVANCE INFORMATION



MULTICHANNEL BUFFERED SERIAL PORT (McBSP) TIMING (CONTINUED)

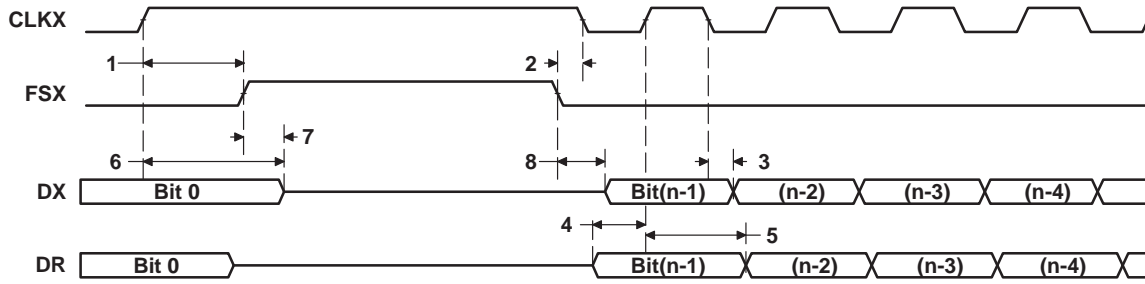

Figure 55. McBSP Timing as SPI Master or Slave: CLKSTP = 10b, CLKXP = 1

TMS320C6414, TMS320C6415, TMS320C6416 FIXED-POINT DIGITAL SIGNAL PROCESSORS

SPRS146L – FEBRUARY 2001 – REVISED JULY 2004

MULTICHANNEL BUFFERED SERIAL PORT (McBSP) TIMING (CONTINUED)

timing requirements for McBSP as SPI Master or Slave: CLKSTP = 11b, CLKXP = 1†‡ (see Figure 56)

| NO. | | -5E0, A-5E0, -6E3, A-6E3, -7E3 | | | | UNIT |
|-----|--|--------------------------------------|-----|---------|-----|------|
| | | MASTER | | SLAVE | | |
| | | MIN | MAX | MIN | MAX | |
| 4 | t _{su} (DRV-CKXH) Setup time, DR valid before CLKX high | 12 | | 2 – 12P | ns | |
| 5 | t _h (CKXH-DRV) Hold time, DR valid after CLKX high | 4 | | 5 + 24P | ns | |

† P = 1/CPU clock frequency in ns. For example, when running parts at 600 MHz, use P = 1.67 ns.

‡ For all SPI Slave modes, CLKG is programmed as 1/4 of the CPU clock by setting CLKSM = CLKGDV = 1.

switching characteristics over recommended operating conditions for McBSP as SPI Master or Slave: CLKSTP = 11b, CLKXP = 1†‡ (see Figure 56)

| NO. | PARAMETER | -5E0, A-5E0, -6E3, A-6E3, -7E3 | | | | UNIT |
|-----|---|--------------------------------------|-------|---------|----------|------|
| | | MASTER§ | | SLAVE | | |
| | | MIN | MAX | MIN | MAX | |
| 1 | t _h (CKXH-FXL) Hold time, FSX low after CLKX high¶ | H – 2 | H + 3 | | | ns |
| 2 | t _d (FXL-CKXL) Delay time, FSX low to CLKX low# | T – 2 | T + 1 | | | ns |
| 3 | t _d (CKXH-DXV) Delay time, CLKX high to DX valid | -2 | 4 | 12P + 4 | 20P + 17 | ns |
| 6 | t _{dis} (CKXH-DXHZ) Disable time, DX high impedance following last data bit from CLKX high | -2 | 4 | 12P + 3 | 20P + 17 | ns |
| 7 | t _d (FXL-DXV) Delay time, FSX low to DX valid | L – 2 | L + 4 | 8P + 2 | 16P + 17 | ns |

† P = 1/CPU clock frequency in ns. For example, when running parts at 600 MHz, use P = 1.67 ns.

‡ For all SPI Slave modes, CLKG is programmed as 1/4 of the CPU clock by setting CLKSM = CLKGDV = 1.

§ S = Sample rate generator input clock = 4P if CLKSM = 1 (P = 1/CPU clock frequency)

= Sample rate generator input clock = P_clks if CLKSM = 0 (P_clks = CLKS period)

T = CLKX period = (1 + CLKGDV) * S

H = CLKX high pulse width = (CLKGDV/2 + 1) * S if CLKGDV is even
= (CLKGDV + 1)/2 * S if CLKGDV is odd or zero

L = CLKX low pulse width = (CLKGDV/2) * S if CLKGDV is even
= (CLKGDV + 1)/2 * S if CLKGDV is odd or zero

¶ FSRP = FSXP = 1. As a SPI Master, FSX is inverted to provide active-low slave-enable output. As a Slave, the active-low signal input on FSX and FSR is inverted before being used internally.

CLKXM = FSXM = 1, CLKRM = FSRM = 0 for Master McBSP

CLKXM = CLKRM = FSXM = FSRM = 0 for Slave McBSP

FSX should be low before the rising edge of clock to enable Slave devices and then begin a SPI transfer at the rising edge of the Master clock (CLKX).

ADVANCE INFORMATION



MULTICHANNEL BUFFERED SERIAL PORT (McBSP) TIMING (CONTINUED)

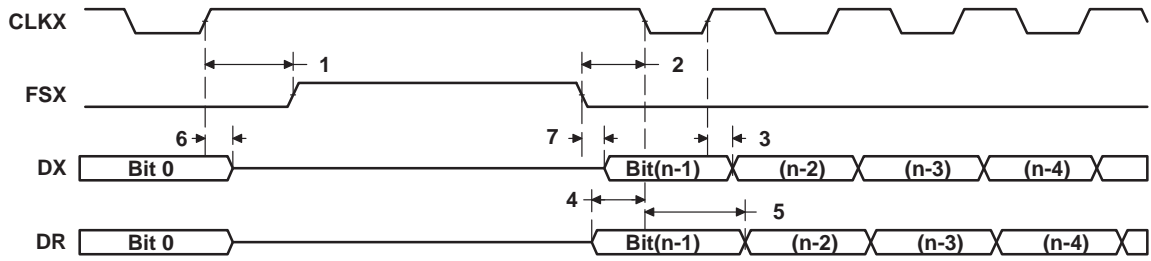

Figure 56. McBSP Timing as SPI Master or Slave: CLKSTP = 11b, CLKXP = 1

TMS320C6414, TMS320C6415, TMS320C6416 FIXED-POINT DIGITAL SIGNAL PROCESSORS

SPRS146L – FEBRUARY 2001 – REVISED JULY 2004

UTOPIA SLAVE TIMING [C6415 AND C6416 ONLY]

timing requirements for UXCLK† (see Figure 57)

| NO. | | -5E0, A-5E0, -6E3, A-6E3, -7E3 | | UNIT |
|-----|--|--------------------------------------|-----------------------|------|
| | | MIN | MAX | |
| 1 | $t_c(\text{UXCK})$ Cycle time, UXCLK | 20 | | ns |
| 2 | $t_w(\text{UXCKH})$ Pulse duration, UXCLK high | $0.4t_c(\text{UXCK})$ | $0.6t_c(\text{UXCK})$ | ns |
| 3 | $t_w(\text{UXCKL})$ Pulse duration, UXCLK low | $0.4t_c(\text{UXCK})$ | $0.6t_c(\text{UXCK})$ | ns |
| 4 | $t_t(\text{UXCK})$ Transition time, UXCLK | 2 | | ns |

† The reference points for the rise and fall transitions are measured at V_{IL} MAX and V_{IH} MIN.

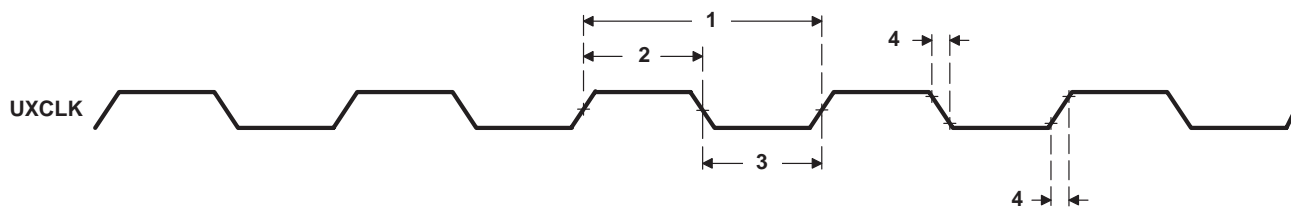

Figure 57. UXCLK Timing

timing requirements for URCLK† (see Figure 58)

| NO. | | -5E0, A-5E0, -6E3, A-6E3, -7E3 | | UNIT |
|-----|--|--------------------------------------|-----------------------|------|
| | | MIN | MAX | |
| 1 | $t_c(\text{URCK})$ Cycle time, URCLK | 20 | | ns |
| 2 | $t_w(\text{URCKH})$ Pulse duration, URCLK high | $0.4t_c(\text{URCK})$ | $0.6t_c(\text{URCK})$ | ns |
| 3 | $t_w(\text{URCKL})$ Pulse duration, URCLK low | $0.4t_c(\text{URCK})$ | $0.6t_c(\text{URCK})$ | ns |
| 4 | $t_t(\text{URCK})$ Transition time, URCLK | 2 | | ns |

† The reference points for the rise and fall transitions are measured at V_{IL} MAX and V_{IH} MIN.

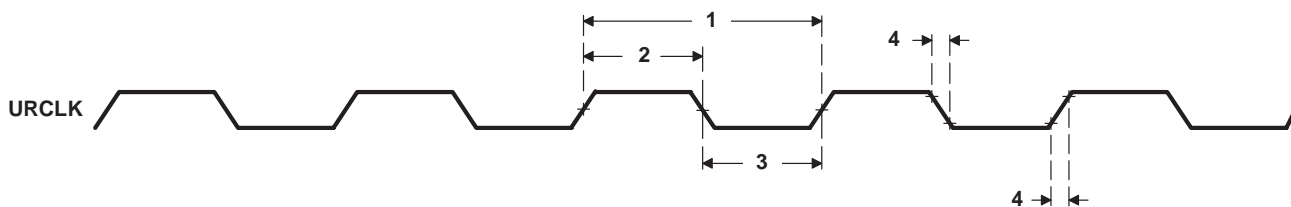

Figure 58. URCLK Timing

ADVANCE INFORMATION

UTOPIA SLAVE TIMING [C6415 AND C6416 ONLY] (CONTINUED)

timing requirements for UTOPIA Slave transmit (see Figure 59)

| NO. | | | -5E0, A-5E0, -6E3, A-6E3, -7E3 | | UNIT |
|-----|-----------------------|--|--------------------------------------|-----|------|
| | | | MIN | MAX | |
| 2 | $t_{su}(UXAV-UXCH)$ | Setup time, UXADDR valid before UXCLK high | 4 | | ns |
| 3 | $t_h(UXCH-UXAV)$ | Hold time, UXADDR valid after UXCLK high | 1 | | ns |
| 8 | $t_{su}(UXENBL-UXCH)$ | Setup time, \overline{UXENB} low before UXCLK high | 4 | | ns |
| 9 | $t_h(UXCH-UXENBL)$ | Hold time, \overline{UXENB} low after UXCLK high | 1 | | ns |

switching characteristics over recommended operating conditions for UTOPIA Slave transmit (see Figure 59)

| NO. | PARAMETER | -5E0, A-5E0, -6E3, A-6E3, -7E3 | | UNIT | |
|-----|-------------------------|--|-----|------|----|
| | | MIN | MAX | | |
| 1 | $t_d(UXCH-UXDV)$ | Delay time, UXCLK high to UXDATA valid | 3 | 12 | ns |
| 4 | $t_d(UXCH-UXCLAV)$ | Delay time, UXCLK high to UXCLAV driven active value | 3 | 12 | ns |
| 5 | $t_d(UXCH-UXCLAVL)$ | Delay time, UXCLK high to UXCLAV driven inactive low | 3 | 12 | ns |
| 6 | $t_d(UXCH-UXCLAVHZ)$ | Delay time, UXCLK high to UXCLAV going Hi-Z | 9 | 18.5 | ns |
| 7 | $t_w(UXCLAVL-UXCLAVHZ)$ | Pulse duration (low), UXCLAV low to UXCLAV Hi-Z | 3 | | ns |
| 10 | $t_d(UXCH-UXSV)$ | Delay time, UXCLK high to UXSOC valid | 3 | 12 | ns |

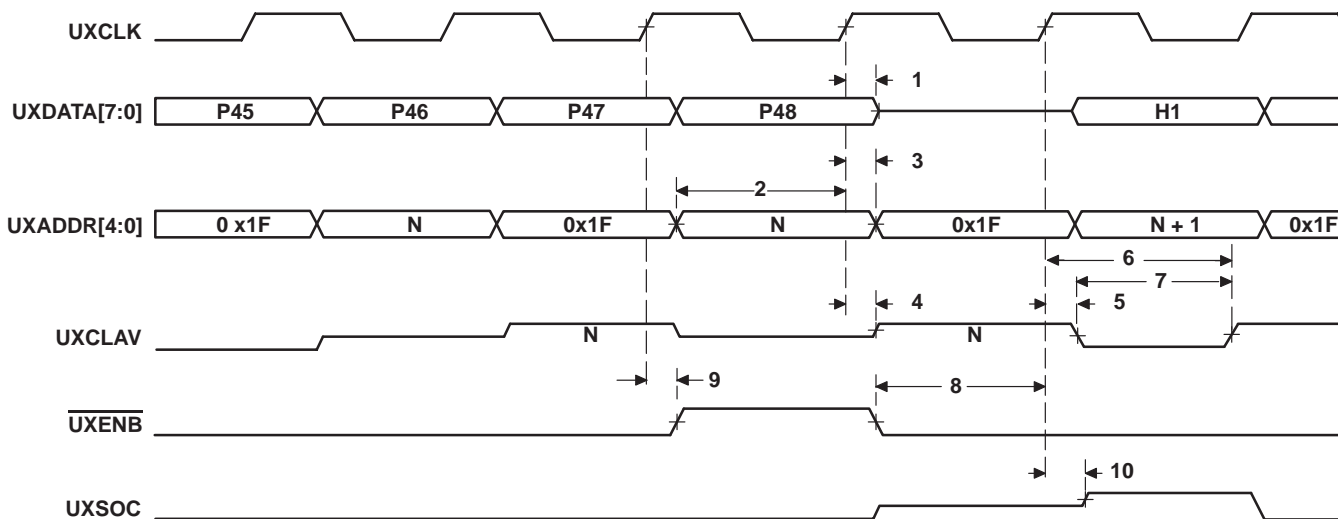

† The UTOPIA Slave module has signals that are middle-level signals indicating a high-impedance state (i.e., the UXCLAV and UXSOC signals).

Figure 59. UTOPIA Slave Transmit Timing†

ADVANCE INFORMATION

TMS320C6414, TMS320C6415, TMS320C6416 FIXED-POINT DIGITAL SIGNAL PROCESSORS

SPRS146L – FEBRUARY 2001 – REVISED JULY 2004

UTOPIA SLAVE TIMING [C6415 AND C6416 ONLY] (CONTINUED)

timing requirements for UTOPIA Slave receive (see Figure 60)

| NO. | | -5E0, A-5E0, -6E3, A-6E3, -7E3 | | UNIT |
|-----|--|--------------------------------------|-----|------|
| | | MIN | MAX | |
| 1 | $t_{su}(URDV-URCH)$ Setup time, URDATA valid before URCLK high | 4 | | ns |
| 2 | $t_h(URCH-URDV)$ Hold time, URDATA valid after URCLK high | 1 | | ns |
| 3 | $t_{su}(URAV-URCH)$ Setup time, URADDR valid before URCLK high | 4 | | ns |
| 4 | $t_h(URCH-URAV)$ Hold time, URADDR valid after URCLK high | 1 | | ns |
| 9 | $t_{su}(URENBL-URCH)$ Setup time, \overline{URENB} low before URCLK high | 4 | | ns |
| 10 | $t_h(URCH-URENBL)$ Hold time, \overline{URENB} low after URCLK high | 1 | | ns |
| 11 | $t_{su}(URSH-URCH)$ Setup time, URSOC high before URCLK high | 4 | | ns |
| 12 | $t_h(URCH-URSH)$ Hold time, URSOC high after URCLK high | 1 | | ns |

switching characteristics over recommended operating conditions for UTOPIA Slave receive (see Figure 60)

| NO. | PARAMETER | -5E0, A-5E0, -6E3, A-6E3, -7E3 | | UNIT |
|-----|--|--------------------------------------|------|------|
| | | MIN | MAX | |
| 5 | $t_d(URCH-URCLAV)$ Delay time, URCLK high to URCLAV driven active value | 3 | 12 | ns |
| 6 | $t_d(URCH-URCLAVL)$ Delay time, URCLK high to URCLAV driven inactive low | 3 | 12 | ns |
| 7 | $t_d(URCH-URCLAVHZ)$ Delay time, URCLK high to URCLAV going Hi-Z | 9 | 18.5 | ns |
| 8 | $t_w(URCLAVL-URCLAVHZ)$ Pulse duration (low), URCLAV low to URCLAV Hi-Z | 3 | | ns |

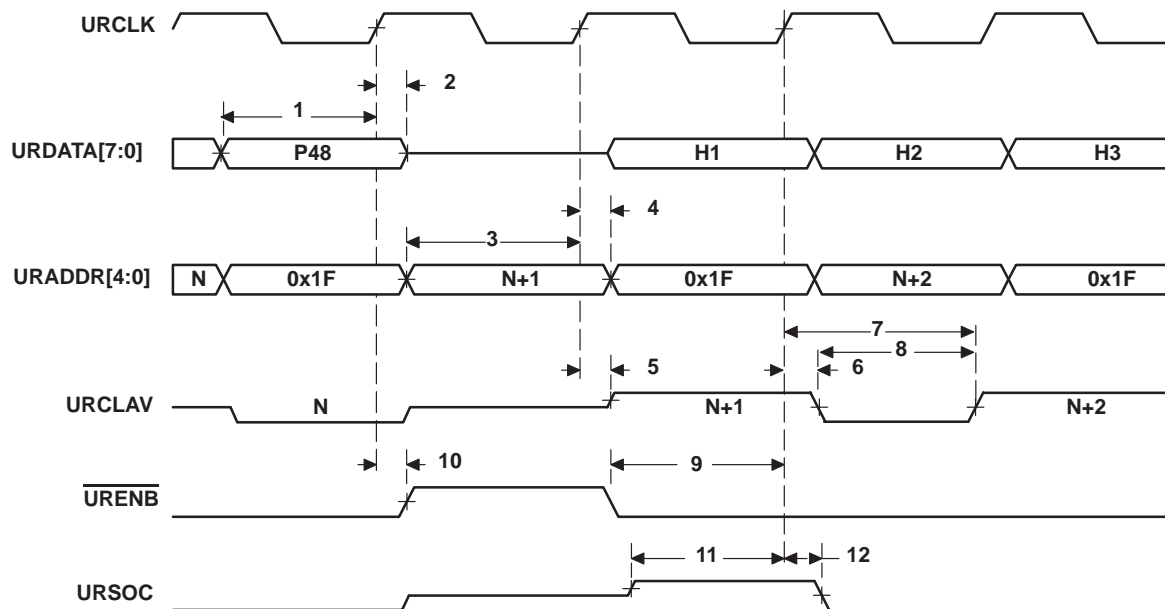

† The UTOPIA Slave module has signals that are middle-level signals indicating a high-impedance state (i.e., the URCLAV and URSOC signals).

Figure 60. UTOPIA Slave Receive Timing†

ADVANCE INFORMATION



TIMER TIMING

timing requirements for timer inputs[†] (see Figure 61)

| NO. | | -5E0, A-5E0, -6E3, A-6E3, -7E3 | | UNIT |
|-----|--|--------------------------------------|-----|------|
| | | MIN | MAX | |
| 1 | $t_w(TINPH)$ Pulse duration, TINP high | 8P | | ns |
| 2 | $t_w(TINPL)$ Pulse duration, TINP low | 8P | | ns |

[†] P = 1/CPU clock frequency in ns. For example, when running parts at 600 MHz, use P = 1.67 ns.

switching characteristics over recommended operating conditions for timer outputs[†]
(see Figure 61)

| NO. | PARAMETER | -5E0, A-5E0, -6E3, A-6E3, -7E3 | | UNIT |
|-----|--|--------------------------------------|-----|------|
| | | MIN | MAX | |
| 3 | $t_w(TOUTH)$ Pulse duration, TOUT high | 8P-3 | | ns |
| 4 | $t_w(TOURL)$ Pulse duration, TOUT low | 8P-3 | | ns |

[†] P = 1/CPU clock frequency in ns. For example, when running parts at 600 MHz, use P = 1.67 ns.

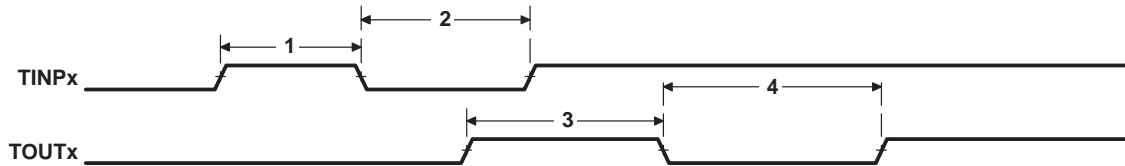

Figure 61. Timer Timing

GENERAL-PURPOSE INPUT/OUTPUT (GPIO) PORT TIMING

timing requirements for GPIO inputs^{†‡} (see Figure 62)

| NO. | | -5E0, A-5E0, -6E3, A-6E3, -7E3 | | UNIT |
|-----|--|--------------------------------------|-----|------|
| | | MIN | MAX | |
| 1 | $t_w(\text{GPIH})$ Pulse duration, GPIx high | 8P | | ns |
| 2 | $t_w(\text{GPIL})$ Pulse duration, GPIx low | 8P | | ns |

[†] P = 1/CPU clock frequency in ns. For example, when running parts at 600 MHz, use P = 1.67 ns.

[‡] The pulse width given is sufficient to generate a CPU interrupt or an EDMA event. However, if a user wants to have the DSP recognize the GPIx changes through software polling of the GPIO register, the GPIx duration must be extended to at least 12P to allow the DSP enough time to access the GPIO register through the CFGBUS.

**switching characteristics over recommended operating conditions for GPIO outputs[†]
(see Figure 62)**

| NO. | PARAMETER | -5E0, A-5E0, -6E3, A-6E3, -7E3 | | UNIT |
|-----|--|--------------------------------------|-----|------|
| | | MIN | MAX | |
| 3 | $t_w(\text{GPOH})$ Pulse duration, GPOx high | 24P - 8 [‡] | | ns |
| 4 | $t_w(\text{GPOL})$ Pulse duration, GPOx low | 24P - 8 [‡] | | ns |

[†] P = 1/CPU clock frequency in ns. For example, when running parts at 600 MHz, use P = 1.67 ns.

[‡] This parameter value should not be used as a maximum performance specification. Actual performance of back-to-back accesses of the GPIO is dependent upon internal bus activity.

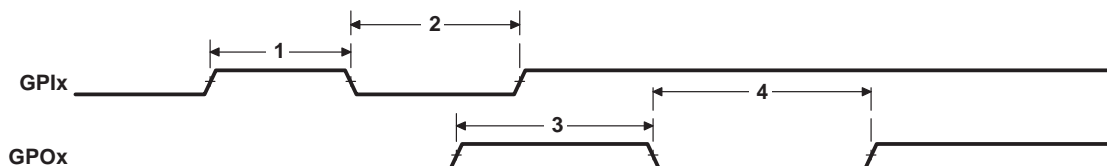

Figure 62. GPIO Port Timing

ADVANCE INFORMATION

JTAG TEST-PORT TIMING

timing requirements for JTAG test port (see Figure 63)

| NO. | | | -5E0, A-5E0, -6E3, A-6E3, -7E3 | | UNIT |
|-----|----------------------|--|--------------------------------------|-----|------|
| | | | MIN | MAX | |
| 1 | t_c (TCK) | Cycle time, TCK | 35 | | ns |
| 3 | t_{su} (TDIV-TCKH) | Setup time, TDI/TMS/TRST valid before TCK high | 10 | | ns |
| 4 | t_h (TCKH-TDIV) | Hold time, TDI/TMS/TRST valid after TCK high | 9 | | ns |

switching characteristics over recommended operating conditions for JTAG test port
(see Figure 63)

| NO. | PARAMETER | -5E0, A-5E0, -6E3, A-6E3, -7E3 | | UNIT |
|-----|-------------------|--------------------------------------|-----|------|
| | | MIN | MAX | |
| 2 | t_d (TCKL-TDOV) | 0 | 18 | ns |

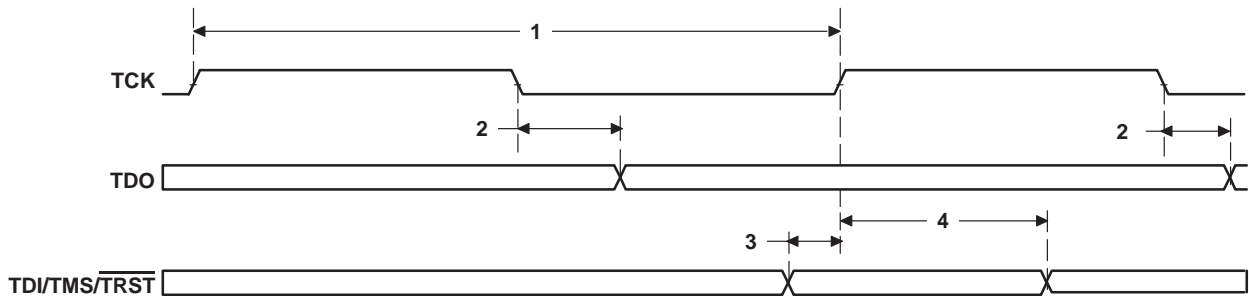

Figure 63. JTAG Test-Port Timing

ADVANCE INFORMATION

TMS320C6414, TMS320C6415, TMS320C6416 FIXED-POINT DIGITAL SIGNAL PROCESSORS

SPRS146L – FEBRUARY 2001 – REVISED JULY 2004

MECHANICAL DATA

The following table(s) show the thermal resistance characteristics for the PBGA — GLZ and ZLZ mechanical packages.

thermal resistance characteristics (S-PBGA package) [GLZ]

| NO. | | Air Flow (m/s†) | °C/W | °C/W (with Heat Sink‡) |
|-----|------------------------------|-----------------|-------|---------------------------|
| 1 | RθJC Junction-to-case | N/A | 1.55 | 1.0 |
| 2 | RθJB Junction-to-board | N/A | 9.1 | 9.0 |
| 3 | RθJA Junction-to-free air | 0.00 | 17.9 | 13.8 |
| 4 | RθJA Junction-to-free air | 0.5 | 15.02 | 8.95 |
| 5 | RθJA Junction-to-free air | 1.0 | 13.4 | 7.35 |
| 6 | RθJA Junction-to-free air | 2.00 | 11.89 | 6.46 |
| 7 | ΨiJT Junction-to-package top | N/A | 0.5 | 0.5 |
| 8 | ΨiJB Junction-to-board | N/A | 7.4 | 7.4 |

† m/s = meters per second

‡ These thermal resistance numbers were modeled using a heat sink, part number 374024B00035, manufactured by AAVID Thermalloy. AAVID Thermalloy also manufactures a similar epoxy-mounted heat sink, part number 374024B00000. When operating at 720 MHz, a heat sink should be used to reduce the thermal resistance characteristics of the package. TI recommends a passive, laminar heat sink, similar to the part numbers mentioned above.

thermal resistance characteristics (S-PBGA package) [ZLZ]

| NO. | | Air Flow (m/s†) | °C/W | °C/W (with Heat Sink‡) |
|-----|------------------------------|-----------------|-------|---------------------------|
| 1 | RθJC Junction-to-case | N/A | 1.55 | 1.0 |
| 2 | RθJB Junction-to-board | N/A | 9.1 | 9.0 |
| 3 | RθJA Junction-to-free air | 0.00 | 17.9 | 13.8 |
| 4 | RθJA Junction-to-free air | 0.5 | 15.02 | 8.95 |
| 5 | RθJA Junction-to-free air | 1.0 | 13.4 | 7.35 |
| 6 | RθJA Junction-to-free air | 2.00 | 11.89 | 6.46 |
| 7 | ΨiJT Junction-to-package top | N/A | 0.5 | 0.5 |
| 8 | ΨiJB Junction-to-board | N/A | 7.4 | 7.4 |

† m/s = meters per second

‡ These thermal resistance numbers were modeled using a heat sink, part number 374024B00035, manufactured by AAVID Thermalloy. AAVID Thermalloy also manufactures a similar epoxy-mounted heat sink, part number 374024B00000. When operating at 720 MHz, a heat sink should be used to reduce the thermal resistance characteristics of the package. TI recommends a passive, laminar heat sink, similar to the part numbers mentioned above.

The following mechanical package diagram(s) reflect the most up-to-date mechanical data released for these designated device(s).

ADVANCE INFORMATION



GLZ (S-PBGA-N532)

PLASTIC BALL GRID ARRAY

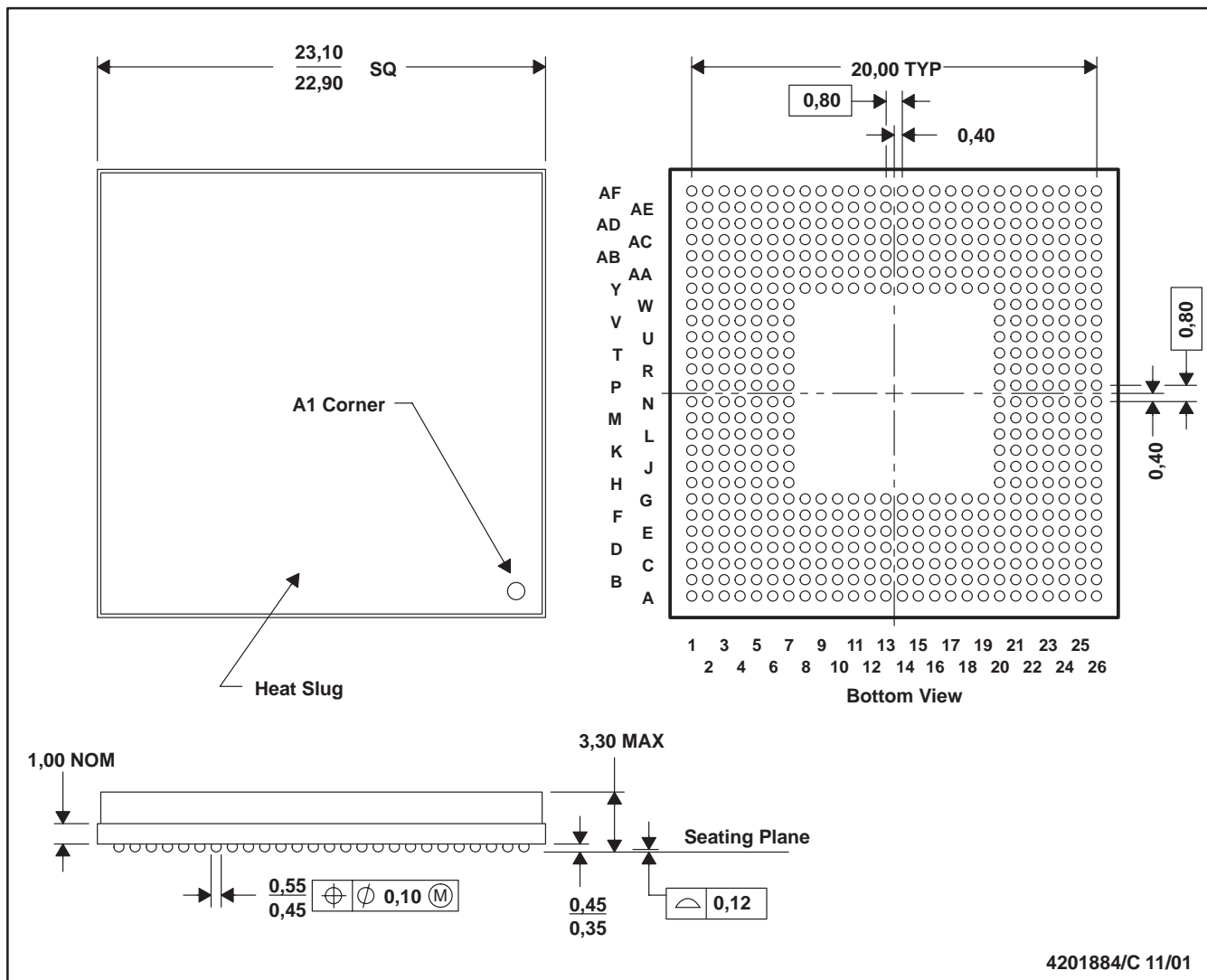

- NOTES: A. All linear dimensions are in millimeters.
 B. This drawing is subject to change without notice.
 C. Thermally enhanced plastic package with heat slug (HSL)
 D. Flip chip application only

ZLZ (S-PBGA-N532)

PLASTIC BALL GRID ARRAY

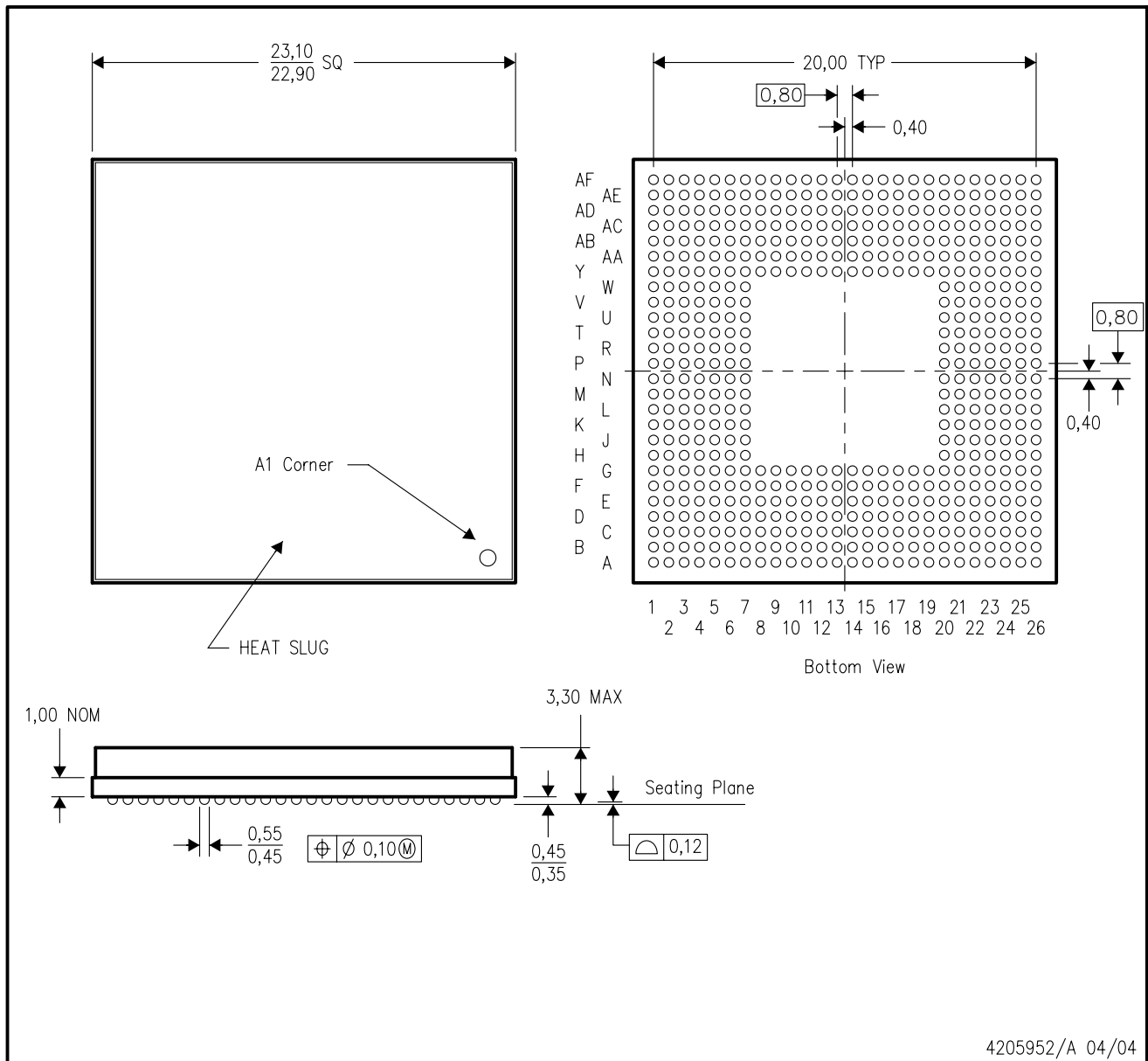

- NOTES:
- A. All linear dimensions are in millimeters.
 - B. This drawing is subject to change without notice.
 - C. Thermally enhanced plastic package with heat slug (HSL).
 - D. Flip chip application only.
 - E. This package is lead-free.

IMPORTANT NOTICE

Texas Instruments Incorporated and its subsidiaries (TI) reserve the right to make corrections, modifications, enhancements, improvements, and other changes to its products and services at any time and to discontinue any product or service without notice. Customers should obtain the latest relevant information before placing orders and should verify that such information is current and complete. All products are sold subject to TI's terms and conditions of sale supplied at the time of order acknowledgment.

TI warrants performance of its hardware products to the specifications applicable at the time of sale in accordance with TI's standard warranty. Testing and other quality control techniques are used to the extent TI deems necessary to support this warranty. Except where mandated by government requirements, testing of all parameters of each product is not necessarily performed.

TI assumes no liability for applications assistance or customer product design. Customers are responsible for their products and applications using TI components. To minimize the risks associated with customer products and applications, customers should provide adequate design and operating safeguards.

TI does not warrant or represent that any license, either express or implied, is granted under any TI patent right, copyright, mask work right, or other TI intellectual property right relating to any combination, machine, or process in which TI products or services are used. Information published by TI regarding third-party products or services does not constitute a license from TI to use such products or services or a warranty or endorsement thereof. Use of such information may require a license from a third party under the patents or other intellectual property of the third party, or a license from TI under the patents or other intellectual property of TI.

Reproduction of information in TI data books or data sheets is permissible only if reproduction is without alteration and is accompanied by all associated warranties, conditions, limitations, and notices. Reproduction of this information with alteration is an unfair and deceptive business practice. TI is not responsible or liable for such altered documentation.

Resale of TI products or services with statements different from or beyond the parameters stated by TI for that product or service voids all express and any implied warranties for the associated TI product or service and is an unfair and deceptive business practice. TI is not responsible or liable for any such statements.

Following are URLs where you can obtain information on other Texas Instruments products and application solutions:

| Products | | Applications | |
|------------------|--|---------------------|--|
| Amplifiers | amplifier.ti.com | Audio | www.ti.com/audio |
| Data Converters | dataconverter.ti.com | Automotive | www.ti.com/automotive |
| DSP | dsp.ti.com | Broadband | www.ti.com/broadband |
| Interface | interface.ti.com | Digital Control | www.ti.com/digitalcontrol |
| Logic | logic.ti.com | Military | www.ti.com/military |
| Power Mgmt | power.ti.com | Optical Networking | www.ti.com/opticalnetwork |
| Microcontrollers | microcontroller.ti.com | Security | www.ti.com/security |
| | | Telephony | www.ti.com/telephony |
| | | Video & Imaging | www.ti.com/video |
| | | Wireless | www.ti.com/wireless |

Mailing Address: Texas Instruments
Post Office Box 655303 Dallas, Texas 75265