

**CONNECTOR DESIGNATORS**  
**A-F-H-L-S**  
**SELF-LOCKING**  
**ROTATABLE**  
**COUPLING**

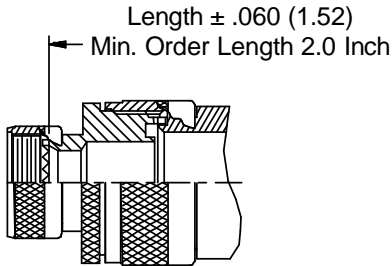

**STYLE 2**  
**(STRAIGHT)**  
 See Note 1)

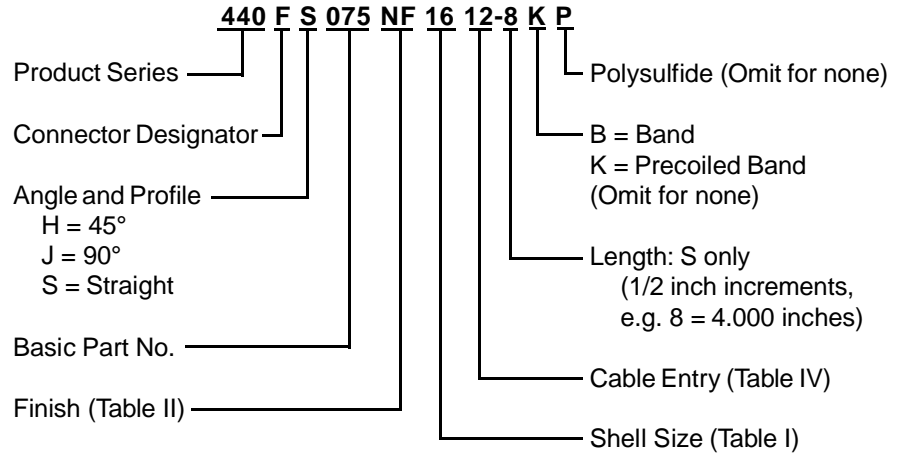
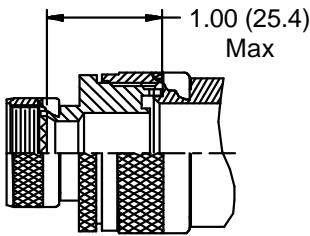
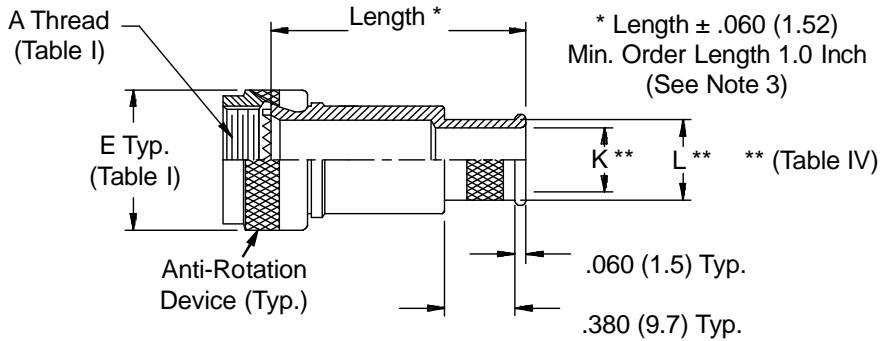

**STYLE 2**  
**(45° & 90°)**  
 See Note 1)

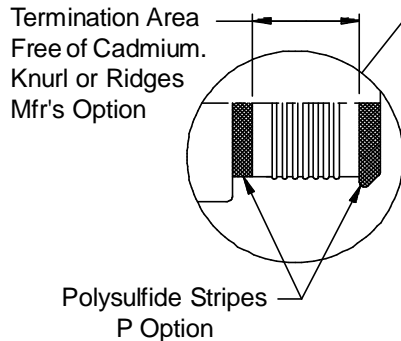
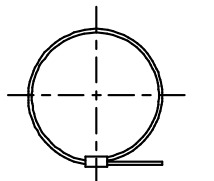
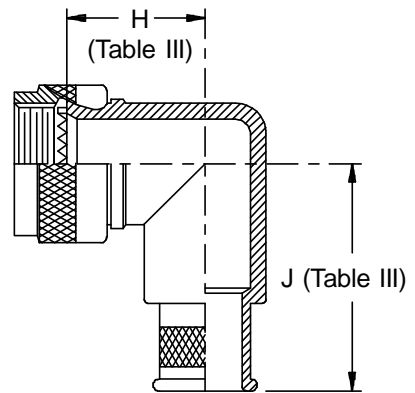
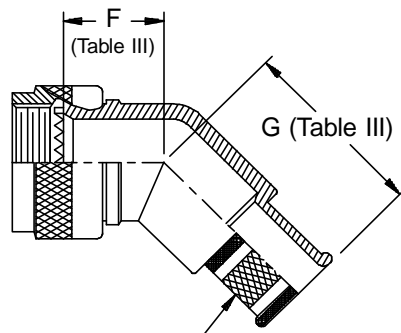

See inside back cover fold-out or pages 13 and 14 for Tables I and II.

**TABLE III: ELBOW DIMENSIONS**

Shell Size		F Max	G Max	H Max	J Max
Conn. Desig. A-F-L-S	H				
08	09	.795 (20.2)	.890 (22.6)	.906 (23.0)	1.000 (25.4)
10	11	.820 (20.8)	.920 (23.4)	.966 (24.5)	1.060 (26.9)
12	13	.844 (21.4)	.940 (23.9)	1.026 (26.1)	1.120 (28.4)
14	15	.861 (21.9)	.970 (24.6)	1.076 (27.3)	1.190 (30.2)
16	17	.888 (22.6)	.990 (25.1)	1.136 (28.9)	1.250 (31.8)
18	19	.904 (23.0)	1.000 (25.4)	1.176 (29.9)	1.270 (32.3)
20	21	.929 (23.6)	1.020 (25.9)	1.236 (31.4)	1.330 (33.8)
22	23	.956 (24.3)	1.060 (26.9)	1.296 (32.9)	1.410 (35.8)
24	25	.979 (24.9)	1.090 (27.7)	1.356 (34.4)	1.480 (37.6)

**TABLE IV: CABLE ENTRY**

Dash No.	K Dia	L Dia
02	.125 (3.2)	.250 (6.4)
03	.188 (4.8)	.312 (7.9)
04	.250 (6.4)	.375 (9.5)
05	.312 (7.9)	.438 (11.1)
06	.375 (9.5)	.500 (12.7)
07	.438 (11.1)	.562 (14.3)
08	.500 (12.7)	.625 (15.9)
09	.562 (14.3)	.688 (17.5)
10	.625 (15.9)	.750 (19.1)
11	.688 (17.5)	.812 (20.6)
12	.750 (19.1)	.875 (22.2)
13	.812 (20.6)	.938 (23.8)
14	.875 (22.2)	1.000 (25.4)
15	.938 (23.8)	1.062 (27.0)
16	1.000 (25.4)	1.125 (28.6)
17	1.062 (27.0)	1.188 (30.2)
18	1.125 (28.6)	1.250 (31.8)
20	1.250 (31.8)	1.375 (34.9)
22	1.375 (34.9)	1.500 (38.1)
24	1.500 (38.1)	1.625 (41.3)

1. When maximum cable entry (page 21) is exceeded, Style 2 will be supplied. Dimensions F, G, H and J will not apply. Please consult factory.
2. Metric dimensions (mm) are indicated in parentheses.
3. Consult factory for shorter lengths on straight backshells.
4. Backshells supplied with 600-052-\* band, see Glenair Series 600 Tool Catalog for installation.