

Agilent HDSP-331x/332E/333x/334x Series 7.62 mm (0.3 inch) General Purpose Seven-Segment Display Data Sheet

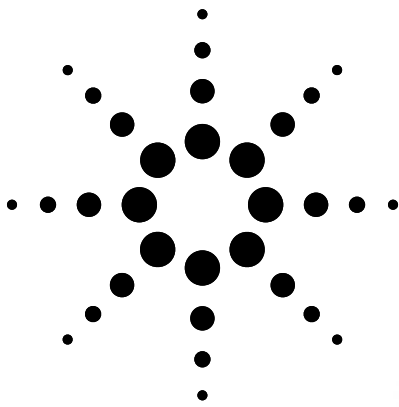

Description

This 7.62 mm (0.3 inch) LED seven-segment display uses industry standard size package and pinout. The device is available in either common anode

or common cathode. The choice of colors includes High Efficiency Red (HER), Green, AlGaAs Red, and Yellow. The gray face displays are suitable for indoor use.

Features

- **Industry standard size**
- **Industry standard pinout**
7.62 mm (0.4 inch) character height
DIP lead on 2.54 mm
- **Choice of colors**
High Efficiency Red (HER), Green, AlGaAs Red, and Yellow
- **Excellent appearance**
Evenly lighted segments gray package gives optimum contrast
 $\pm 50^\circ$ viewing angle
- **Design flexibility**
Common anode or common cathode
Single digit
Left and right hand decimal point
- **Categorized for luminous intensity**
Green and yellow categorized for color

Applications

- **Suitable for indoor use**
- **Not recommended for industrial application, i.e., operating temperature requirements exceeding +85°C or below -25°C^[1]**
- **Extreme temperature cycling not recommended**

Note:

1. For additional details, please contact your local Agilent sales office or an authorized distributor.

Devices

| HER | Green | AlGaAs Red | Yellow | Description | Package Drawing |
|-----------|-----------|------------|-----------|--|-----------------|
| HDSP-331E | HDSP-331G | HDSP-331A | HDSP-331Y | Common Anode, Right Hand and Left Hand Decimal | A |
| HDSP-332E | | | | Common Anode, Right Hand and Left Hand Decimal without Pin 4, 5 and 12 | A |
| HDSP-333E | HDSP-333G | HDSP-333A | HDSP-333Y | Common Cathode, Right Hand Decimal | B |
| HDSP-334E | HDSP-334G | HDSP-334A | HDSP-334Y | Common Cathode, Right Hand Decimal | C |



Part Numbering System

5082 -X X X X-X X X X X

HDSP-X X X X-X X X X X

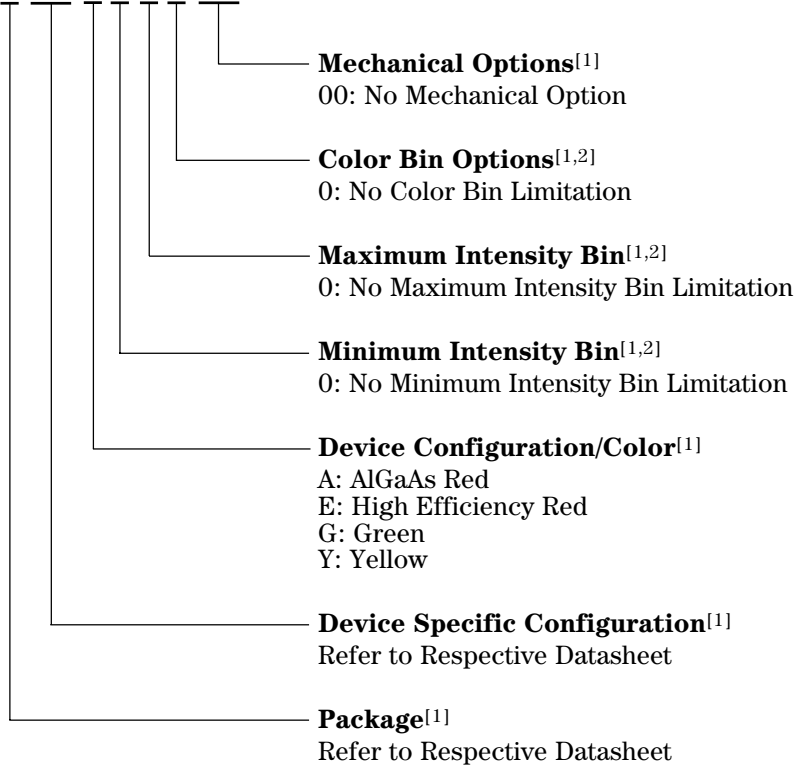

Notes:

1. For codes not listed in the figure above, please refer to the respective datasheet or contact your nearest Agilent representative for details.
2. Bin options refer to shippable bins for a part number. Color and Intensity Bins are typically restricted to 1 bin per tube (exceptions may apply). Please refer to respective datasheet for specific bin limit information.

Package Dimensions

Package Drawing A

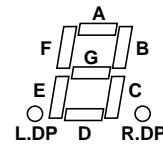
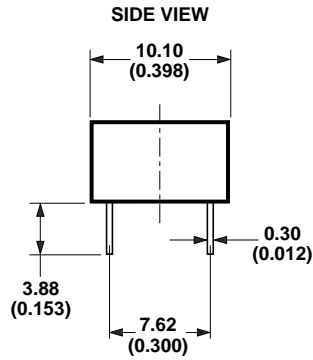
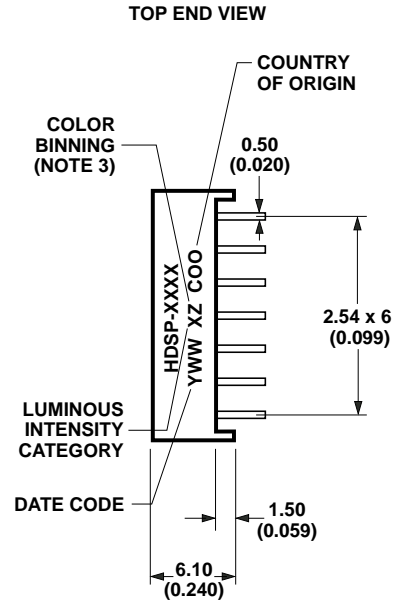
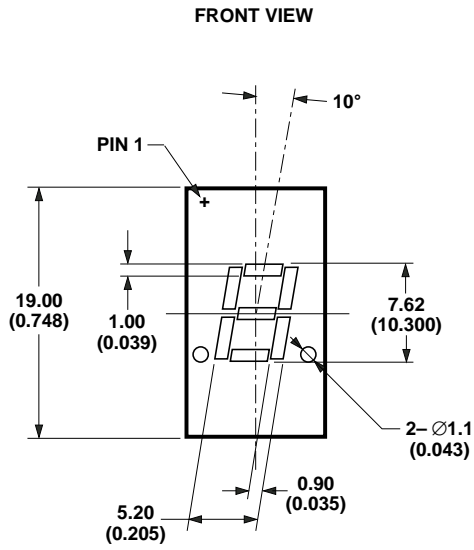

DIMENSIONS IN MILLIMETERS (INCHES)

NOTE: HDSP-332E DOES NOT HAVE PIN 4, 5 AND 12.

Package Dimensions

Package Drawing B

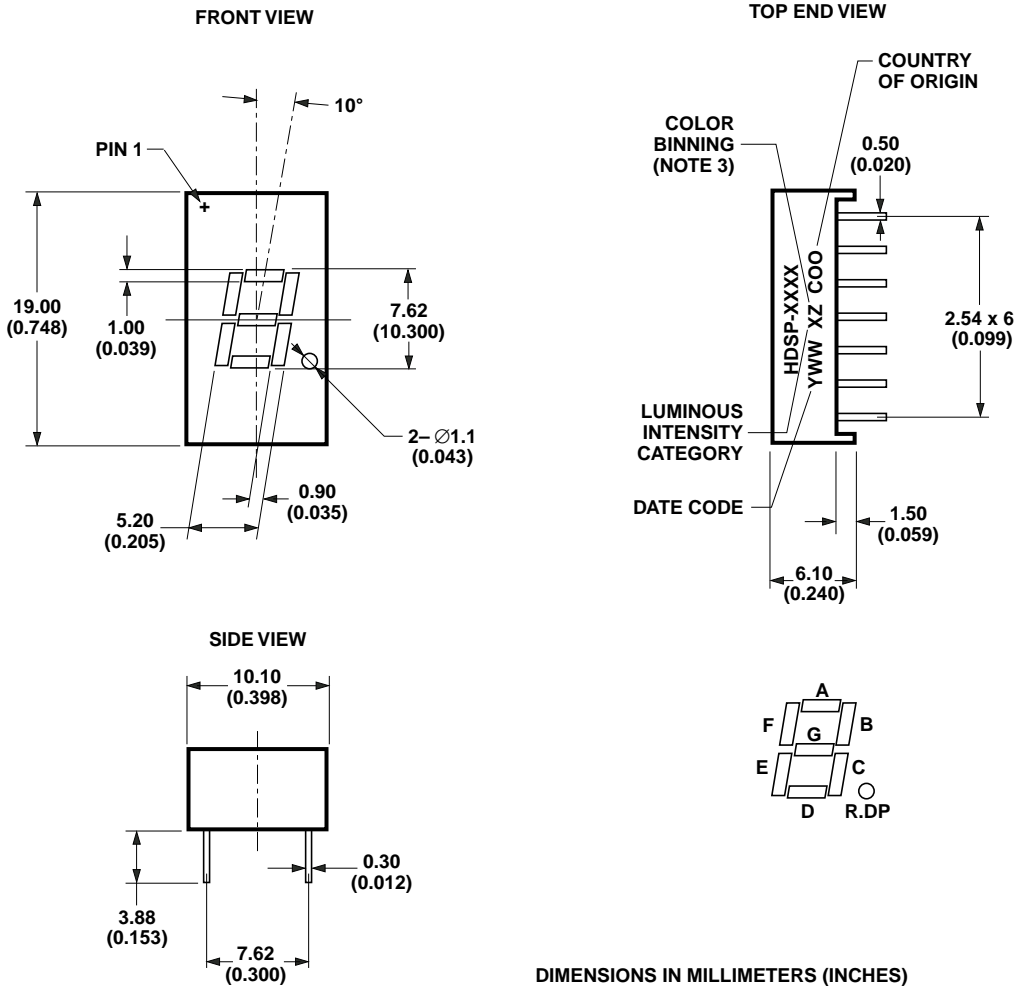

Package Dimensions

Package Drawing C

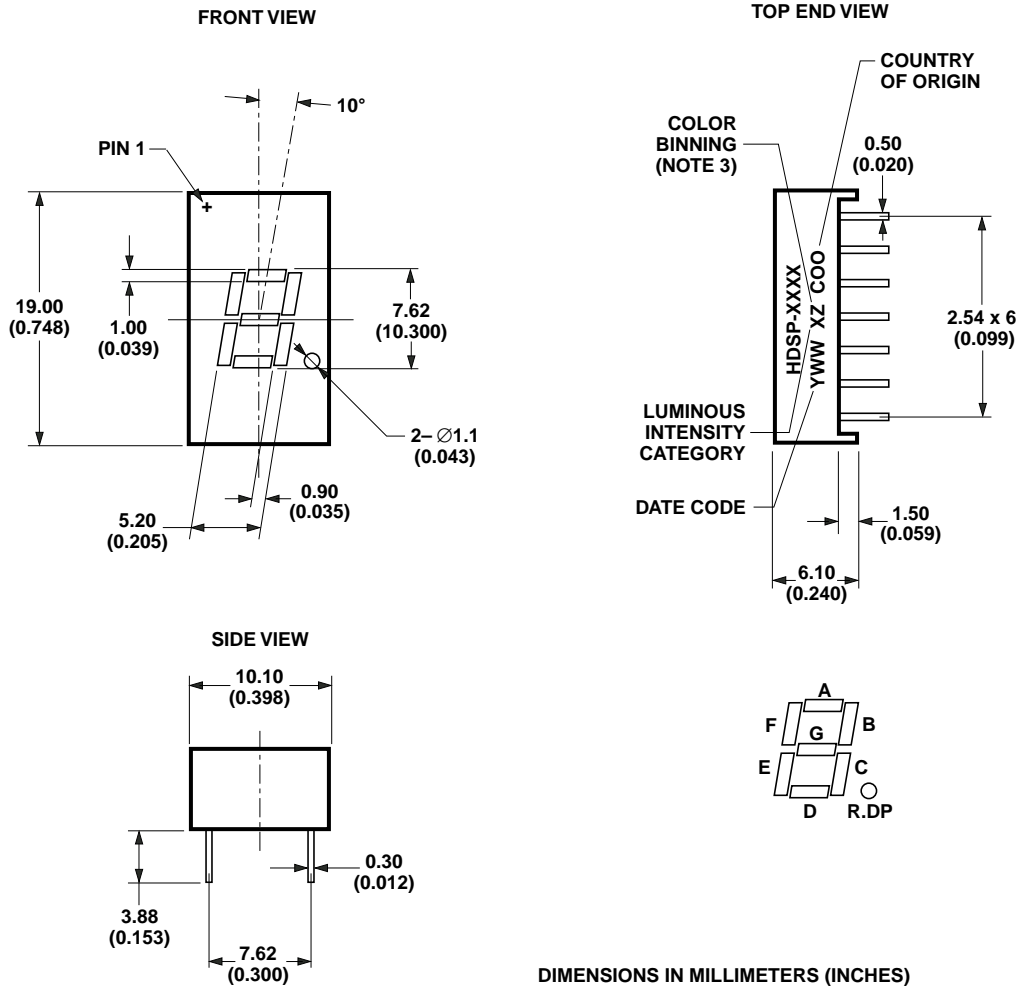

DIMENSIONS IN MILLIMETERS (INCHES)

Internal Circuit Diagram

Common Anode

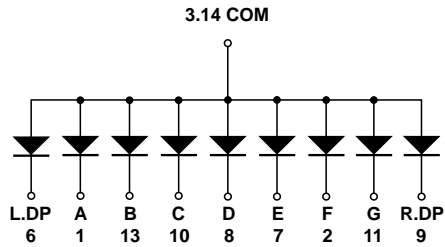

HDSP-331E/331G/331Y/331A/332E

| PIN NO. | CONNECTION |
|--|--------------|
| 1 | CATHODE A |
| 2 | CATHODE F |
| 3 | COMMON ANODE |
| 6 | CATHODE L.DP |
| 7 | CATHODE E |
| 8 | CATHODE D |
| 9 | CATHODE R.DP |
| 10 | CATHODE C |
| 11 | CATHODE G |
| 13 | CATHODE B |
| 14 | COMMON ANODE |
| PINS 4, 5, 12: NO CONNECTION FOR HDSP-331E/331G/331Y/331A AND NO PIN FOR HDSP-332E | |

Common Cathode

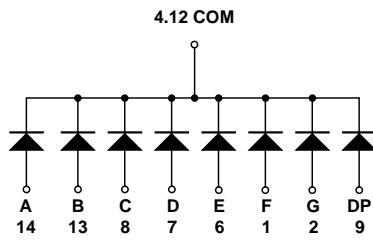

HDSP-333E/333G/333Y/333A

| PIN NO. | CONNECTION |
|-----------------------|----------------|
| 1 | ANODE F |
| 2 | ANODE G |
| 4 | COMMON CATHODE |
| 6 | ANODE E |
| 7 | ANODE D |
| 8 | ANODE C |
| 9 | ANODE DP |
| 12 | COMMON CATHODE |
| 13 | ANODE B |
| 14 | ANODE A |
| PINS 3, 5, 10, 11: NC | |

Internal Circuit Diagram

Common Cathode

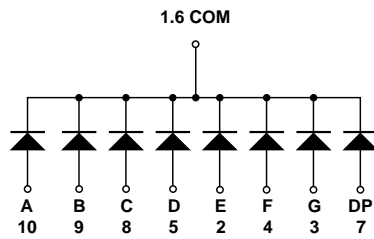

HDSP-334E/334G/334Y/334A

| PIN NO. | CONNECTION |
|-------------------------|----------------|
| 1 | COMMON CATHODE |
| 2 | ANODE E |
| 3 | ANODE G |
| 4 | ANODE F |
| 5 | ANODE D |
| 6 | COMMON CATHODE |
| 7 | ANODE DP |
| 8 | ANODE C |
| 9 | ANODE B |
| 10 | ANODE A |
| PINS 11, 12, 13, 14: NC | |

Absolute Maximum Ratings at T_A = 25 °C

| Description | HER HDSP-33xE | Green HDSP-33xG | AlGaAs Red HDSP-33xA | Yellow HDSP-33xY | Units |
|--|-------------------|--------------------|-------------------------|---------------------|-------|
| Power Dissipation Segment | 65 | 65 | 30 | 52 | mW |
| Forward Current Segment | 25 ^[1] | 25 ^[2] | 15 ^[3] | 20 ^[4] | mA |
| Peak Forward Current per Segment (1/10 Duty Factor at 10 kHz) | 100 | 100 | 80 | 80 | mA |
| Operating Temperature Range | -35 to +85 | -35 to +85 | -35 to +85 | -35 to +85 | °C |
| Storage Temperature Range | -35 to +85 | -35 to +85 | -35 to +85 | -35 to +85 | °C |
| Reverse Voltage per Segment or DP | 5 | 5 | 5 | 5 | V |
| Wave Soldering Temperature for 3 Seconds (at 2 mm Distance from the Body) | 250 | 250 | 250 | 250 | °C |

Notes:

1. Derate above 25 °C at 0.33 mA/°C.
2. Derate above 25 °C at 0.33 mA/°C.
3. Derate above 25 °C at 0.2 mA/°C.
4. Derate above 25 °C at 0.27 mA/°C.

Electrical/Optical Characteristics at T_A = 25 °C

High Efficiency Red (HER)

| Devices | | | | | | | |
|---------|----------------------------|-------------------|------|------|------|-------|-------------------------|
| HDSP- | Parameter | Symbol | Min. | Typ. | Max. | Units | Test Conditions |
| | Luminous Intensity/Segment | I _V | | 1.15 | | mcd | I _F = 5 mA |
| | | | 0.8 | 1.80 | | mcd | I _F = 10 mA |
| 331E | Forward Voltage | V _F | | 2.05 | 2.40 | V | I _F = 20 mA |
| 332E | Peak Wavelength | λ _{PEAK} | | 635 | | nm | |
| 333E | Dominant Wavelength | λ _d | | 620 | | nm | |
| 334E | Reverse Voltage | VR | 5 | | | V | I _R = 100 μA |

Green

| Devices | | | | | | | |
|---------|----------------------------|-------------------|------|------|------|-------|-------------------------|
| HDSP- | Parameter | Symbol | Min. | Typ. | Max. | Units | Test Conditions |
| | Luminous Intensity/Segment | I _V | 0.8 | 2.00 | | mcd | I _F = 10 mA |
| | | | | 2.07 | | V | I _F = 10 mA |
| 331G | Forward Voltage | V _F | 1.80 | 2.25 | 2.60 | V | I _F = 20 mA |
| 333G | Peak Wavelength | λ _{PEAK} | | 568 | | nm | |
| 334G | Dominant Wavelength | λ _d | | 573 | | nm | |
| | Reverse Voltage | VR | 5 | | | V | I _R = 100 μA |

AlGaAs Red

| Devices | | | | | | | |
|----------------------|----------------------------|------------------|-------|------|------|-------|-------------------------|
| HDSP- | Parameter | Symbol | Min. | Typ. | Max. | Units | Test Conditions |
| 331A 333A 334A | Luminous Intensity/Segment | I_V | | 3.93 | | mcd | $I_F = 5 \text{ mA}$ |
| | | | 2.001 | 4.20 | | mcd | $I_F = 10 \text{ mA}$ |
| | Forward Voltage | V_F | | 1.85 | 2.00 | V | $I_F = 20 \text{ mA}$ |
| | Peak Wavelength | λ_{PEAK} | | 660 | | nm | |
| | Dominant Wavelength | λ_d | | 643 | | nm | |
| | Reverse Voltage | V_R | 5 | | | V | $I_R = 100 \mu\text{A}$ |

Yellow

| Devices | | | | | | | |
|----------------------|----------------------------|------------------|------|------|------|-------|-------------------------|
| HDSP- | Parameter | Symbol | Min. | Typ. | Max. | Units | Test Conditions |
| 331Y 333Y 334Y | Luminous Intensity/Segment | I_V | | 0.71 | | mcd | $I_F = 5 \text{ mA}$ |
| | | | 0.80 | 1.50 | | mcd | $I_F = 10 \text{ mA}$ |
| | Forward Voltage | V_F | | 2.15 | 2.60 | V | $I_F = 20 \text{ mA}$ |
| | Peak Wavelength | λ_{PEAK} | | 595 | | nm | |
| | Dominant Wavelength | λ_d | | 590 | | nm | |
| | Reverse Voltage | V_R | 5 | | | V | $I_R = 100 \mu\text{A}$ |

Intensity Bin Limits (mcd at 10 mA)

| Bin Name | HER/Green/Yellow | | AlGaAs Red | |
|----------|---------------------|---------------------|---------------------|---------------------|
| | Min. ^[1] | Max. ^[1] | Min. ^[1] | Max. ^[1] |
| G | 0.801 | 1.250 | NA | NA |
| H | 1.251 | 2.000 | NA | NA |
| I | 2.001 | 3.200 | 2.001 | 3.200 |
| J | NA | NA | 3.201 | 5.050 |
| K | NA | NA | 5.051 | 8.000 |

Note:

1. Tolerance for each bin limit is $\pm 10\%$.

Color Bin Limits (nm at 10 mA)

| Color | Bin | Dominant Wavelength (nm) | |
|--------|-----|--------------------------|---------------------|
| | | Min. ^[1] | Max. ^[1] |
| Green | 3 | 569.1 | 571.0 |
| | 4 | 571.1 | 573.0 |
| | 5 | 573.1 | 575.0 |
| Yellow | 1 | 585.5 | 588.5 |
| | 2 | 588.5 | 591.5 |
| | 3 | 591.5 | 594.5 |

Note:

1. Tolerance for each bin limit is 1 nm.

High Efficiency Red (HER)

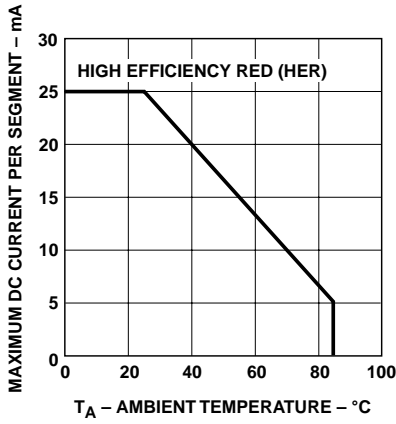

Figure 1. Maximum allowable average or DC current vs. ambient temperature.

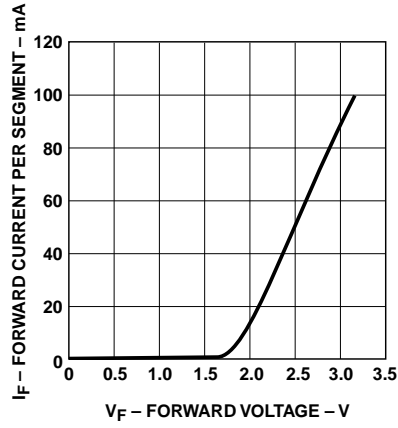

Figure 2. Forward current vs. forward voltage.

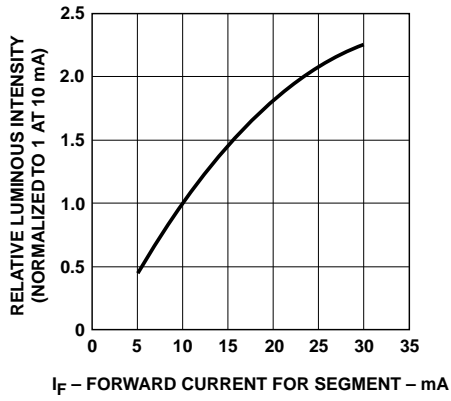

Figure 3. Relative luminous intensity vs. DC forward current.

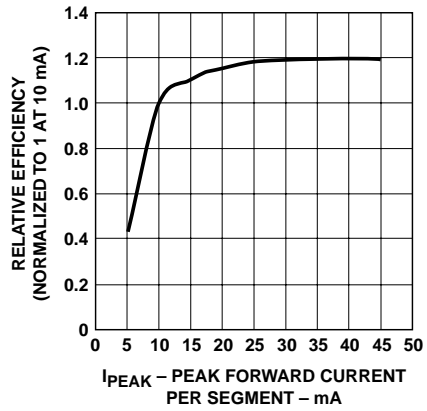

Figure 4. Relative efficiency (luminous intensity per unit current) vs. peak current.

Green

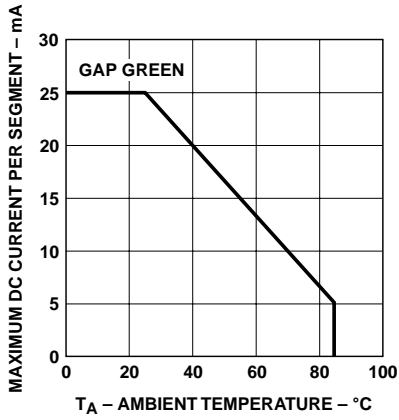

Figure 5. Maximum allowable average or DC current vs. ambient temperature.

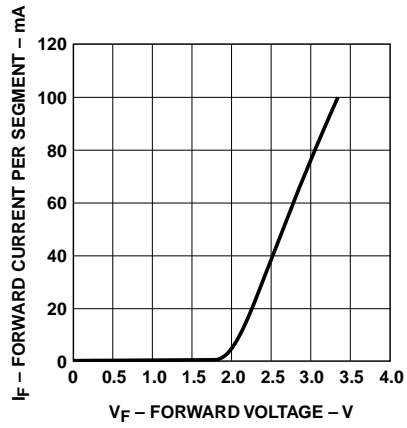

Figure 6. Forward current vs. forward voltage.

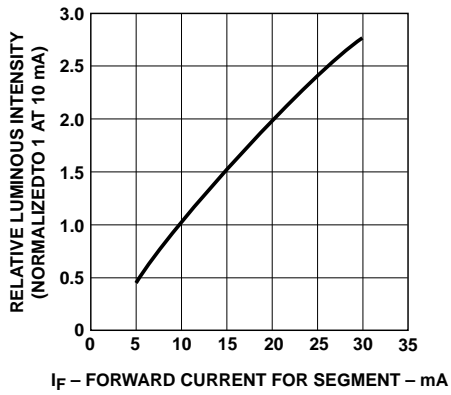

Figure 7. Relative luminous intensity vs. DC forward current.

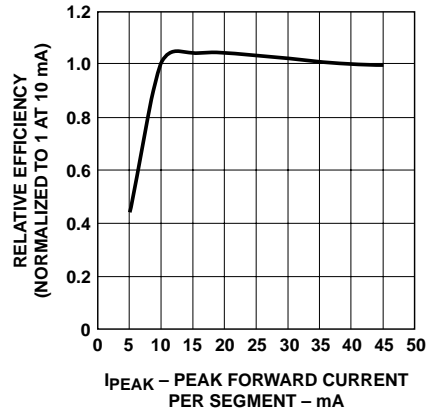

Figure 8. Relative efficiency (luminous intensity per unit current) vs. peak current.

AlGaAs Red

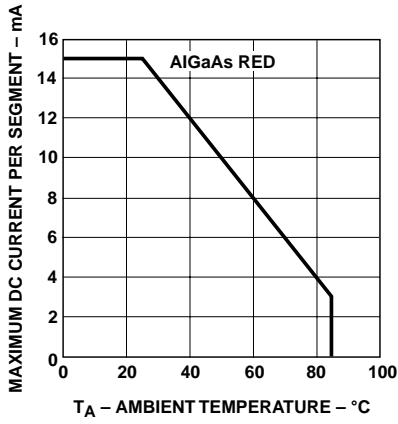

Figure 9. Maximum allowable average or DC current vs. ambient temperature.

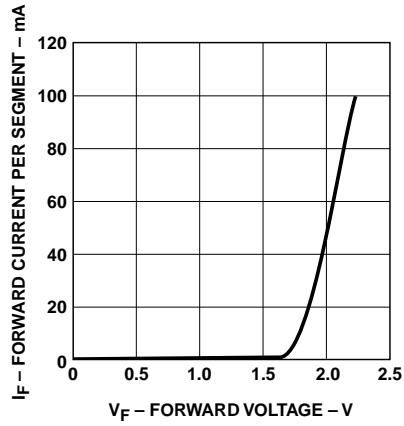

Figure 10. Forward current vs. forward voltage.

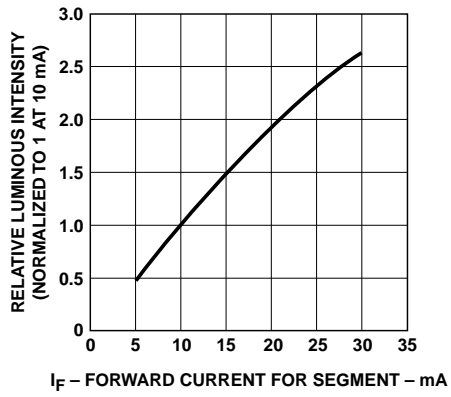

Figure 11. Relative luminous intensity vs. DC forward current.

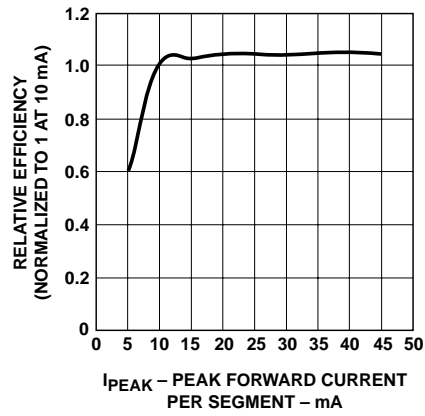

Figure 12. Relative efficiency (luminous intensity per unit current) vs. peak current.

Yellow

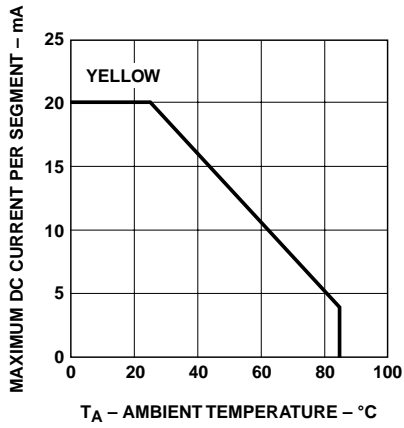

Figure 13. Maximum allowable average or DC current vs. ambient temperature.

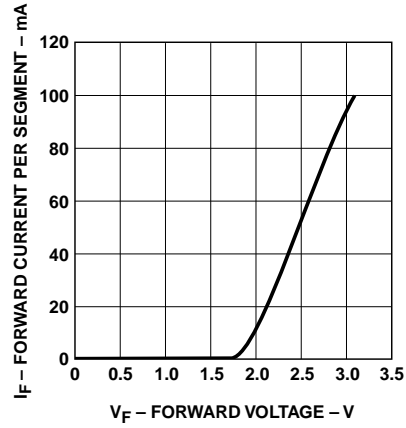

Figure 14. Forward current vs. forward voltage.

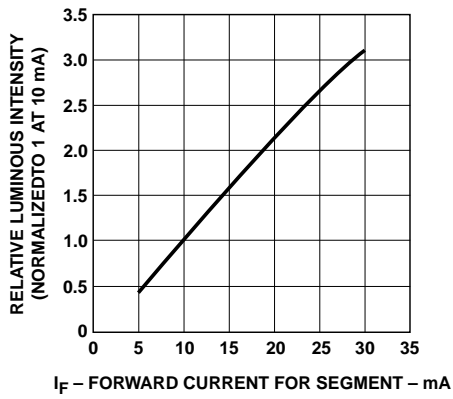

Figure 15. Relative luminous intensity vs. DC forward current.

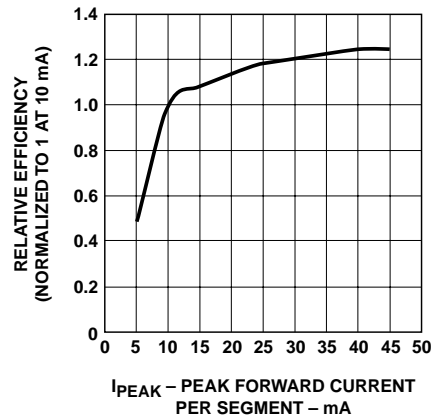

Figure 16. Relative efficiency (luminous intensity per unit current) vs. peak current.

www.agilent.com/semiconductors

For product information and a complete list of distributors, please go to our web site.

For technical assistance call:

Americas/Canada: +1 (800) 235-0312 or (916) 788-6763

Europe: +49 (0) 6441 92460

China: 10800 650 0017

Hong Kong: (+65) 6756 2394

India, Australia, New Zealand: (+65) 6755 1939

Japan: (+81 3) 3335-8152(Domestic/International), or 0120-61-1280(Domestic Only)

Korea: (+65) 6755 1989

Singapore, Malaysia, Vietnam, Thailand, Philippines, Indonesia: (+65) 6755 2044

Taiwan: (+65) 6755 1843

Data subject to change.

Obsoletes 5988-2971EN

July 17, 2004

5988-9421EN



Agilent Technologies