

REV -	AUTH RL	DATE 06/24/04	INITIAL RELEASE
REV A	AUTH DRH	DATE 07/01/05	FORMAT UPDATE
REV B	AUTH RL	DATE 09/13/06	FORMAT UPDATE, NOTES REVISED.

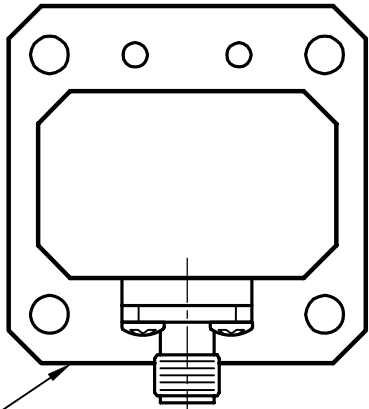

FLANGE PER ORDER,  
SEE TABLE

*FLANGE TYPES		
C1	COVER	ALT. THRU/TAPPED
C2	COVER	ALL TAPPED
C3	COVER	ALL THROUGH
G1	GROOVE	ALT. THRU/TAPPED
G2	GROOVE	ALL TAPPED
G3	GROOVE	ALL THROUGH

SMA-F CONN.,  
1/4-36 UNS-2A THD.

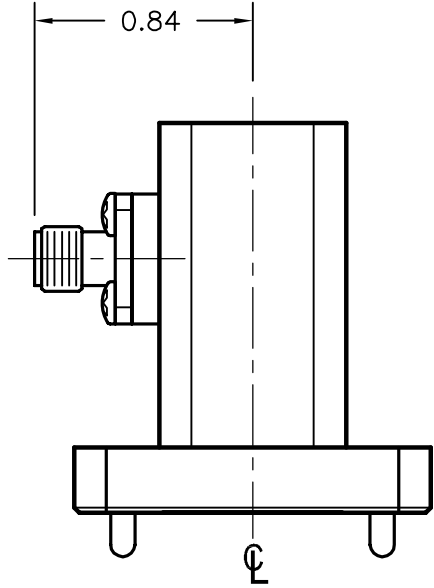
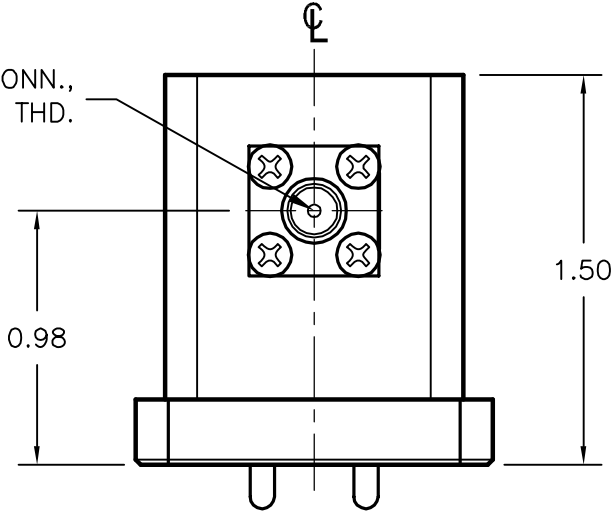

**PERFORMANCE SPECIFICATIONS**

MODEL NUMBER: 580-251-FLANGE TYPE\*  
 WG SIZE: WRD580  
 FREQ: 5.8 - 16.0 GHz  
 MAX. VSWR: 1.25  
 FLANGE TYPE: SEE TABLE  
 FINISH: UNIQUE CORROSION RESISTANT  
 316 STAINLESS STEEL EPOXY

THIRD ANGLE PROJECTION:		APPROVALS	DATE	<b>ADVANCED TECHNICAL MATERIALS, INC.</b> TEL: (631) 289-0363 FAX: (631) 289-0358 www.atmmicrowave.com	<small>THE INFORMATION IN THIS DRAWING IS PROPRIETARY AND SHALL NOT BE USED OR DISCLOSED WITHOUT THE PRIOR WRITTEN CONSENT OF ATM, INC. DO NOT SCALE DWG.</small>		
UNLESS OTHERWISE NOTED, DIMENSIONS ARE IN INCHES, TOLERANCES ARE: FRACTIONS: ±1/64 ANGLES: ±1/2°		DRAWN <b>RL</b>	<b>09/13/06</b>		<b>OUTLINE, WRD580</b> <b>SMA - WAVEGUIDE ADAPTER</b>		
BASIC DIMENSION	DECIMALS 2 PLACE 3 PLACE	CHKD.	APRVD.	SIZE <b>A</b>			
UNDER 6"	±.02 ±.005	MATERIAL <b>ALUM.</b>		SCALE <b>NONE</b>	MODEL # <b>580-251-XX</b>		SHEET <b>1/1</b>
6" - 12"	±.03 ±.010	TREATMENT <b>IRIDITE</b>					
OVER 12"	±.06 ±.015	FINISH <b>SEE NOTES</b>					