

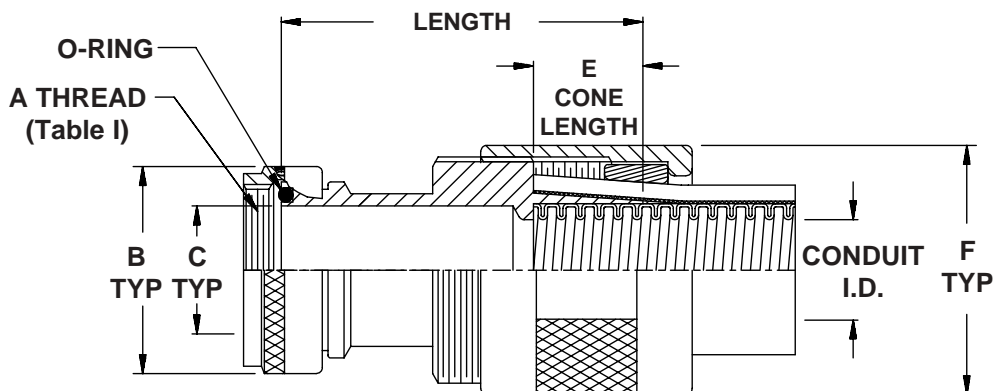

712-387
Straight, 45° & 90° Environmental User-Installable
Fitting for Series 75 Flexible Metal-Core Conduit

**TO BE USED WITH
ADAPTERS AND
TRANSITIONS
SHOWN ON PAGES
G-1 THROUGH G-8**

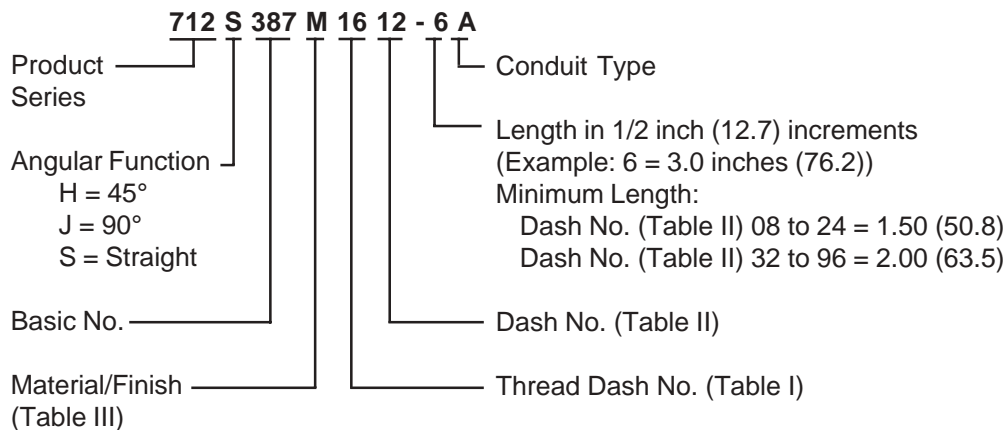

STRAIGHT

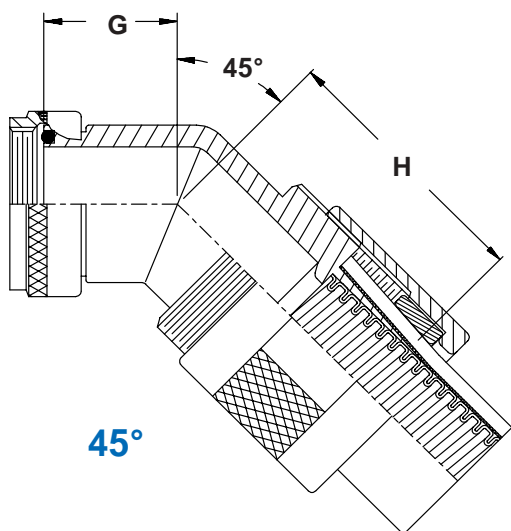

45°

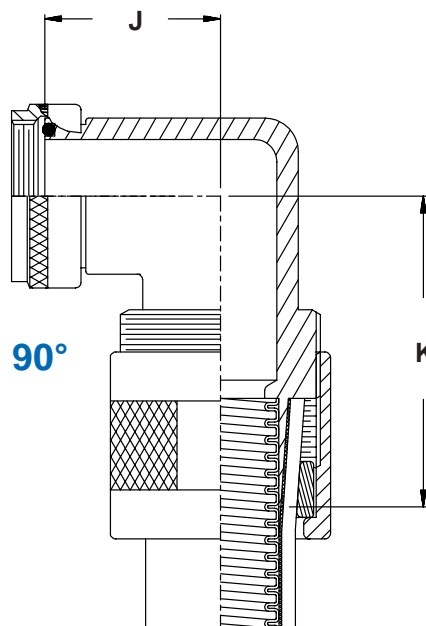

90°

TABLE I

DASH NO.	A THREAD CLASS 2B	B MAX	C DIA
08	1/2 - 20 UNF	.640 (16.3)	.250 (6.4)
12	5/8 - 24 UNEF	.760 (19.3)	.375 (9.5)
16	3/4 - 20 UNEF	.890 (22.6)	.500 (12.7)
20	7/8 - 20 UNEF	1.024 (26.0)	.625 (15.9)
24	1 - 20 UNEF	1.152 (29.3)	.750 (19.1)
32	1 5/16 - 18 UNEF	1.488 (37.8)	1.000 (25.4)
40	1 1/2 - 18 UNEF	1.676 (42.6)	1.250 (31.8)
48	1 3/4 - 18 UNS	1.960 (49.8)	1.500 (38.1)
56	2 - 18 UNS	2.210 (56.1)	1.750 (44.5)
64	2 1/4 - 16 UN	2.460 (62.5)	2.000 (50.8)
80	2 3/4 - 16 UN	2.930 (74.4)	2.500 (63.5)
96	3 1/4 - 16 UN	3.450 (87.6)	3.000 (76.2)

NOTES:

1. Metric dimensions (mm), are in parentheses.
2. F dimension is based on type A construction. Add .125 (3.2) to listed dimensions for each additional shield types B through D.

TABLE II

DASH NO.	CONDUIT I.D.	E	F MAX (NOTE 2)	G MAX	H MAX	J MAX	K MAX
08	.250 (6.4)	.75 (19.1)	1.16 (29.5)	.624 (15.8)	1.700 (43.2)	.750 (19.1)	1.810 (46.0)
12	.375 (9.5)	.75 (19.1)	1.34 (34.0)	.654 (16.6)	1.730 (43.9)	.810 (20.6)	1.870 (47.5)
16	.500 (12.7)	.75 (19.1)	1.46 (37.1)	.688 (17.5)	1.750 (44.5)	.870 (22.1)	1.930 (49.0)
20	.625 (15.9)	.75 (19.1)	1.65 (41.9)	.705 (17.9)	1.780 (45.2)	.920 (23.4)	2.000 (50.8)
24	.750 (19.1)	.75 (19.1)	1.84 (46.7)	.732 (18.6)	1.800 (45.7)	.980 (24.9)	2.060 (52.3)
32	1.000 (25.4)	1.00 (25.4)	2.02 (51.3)	.773 (19.6)	2.020 (51.3)	1.080 (27.4)	2.390 (60.7)
40	1.250 (31.8)	1.00 (25.4)	2.34 (59.4)	.823 (20.9)	2.090 (53.1)	1.200 (30.5)	2.540 (64.5)
48	1.500 (38.1)	1.00 (25.4)	2.72 (69.0)	1.041 (26.4)	2.360 (59.9)	1.480 (37.6)	2.870 (72.9)
56	1.750 (44.5)	1.00 (25.4)	2.96 (75.2)	1.062 (27.0)	2.410 (61.2)	1.550 (39.4)	2.960 (75.2)
64	2.000 (50.8)	1.00 (25.4)	3.22 (81.8)	1.092 (27.7)	2.450 (62.2)	1.610 (40.9)	3.070 (78.0)
80	2.500 (63.5)	1.00 (25.4)	3.86 (98.0)	1.190 (30.2)	2.550 (64.8)	1.860 (47.2)	3.320 (84.3)
96	3.000 (76.2)	1.00 (25.4)	4.38 (111.3)	1.250 (31.8)	2.610 (66.3)	1.990 (50.5)	3.450 (87.6)

TABLE III

SYMBOL	MATERIAL	FINISH
A	Aluminum Alloy, 6061-T6 per QQ-A-225/8	Cadmium, Olive Drab, per QQ-P-416, over Electroless Nickel per ASTM B733-90, and MIL-C-26074, 500 Hour Salt Spray
B	Brass, ASTM B16 per QQ-B-626	
C	Corrosion Resistant Steel per QQ-S-763, 300 Series	Passivate per QQ-P-35
M	Aluminum Alloy, 6061-T6 per QQ-A-225/8	Electroless Nickel per ASTM B733-90 and MIL-C-26074
NC	Aluminum Alloy, 6061-T6 per QQ-A-225/8	Zinc Cobalt, Olive Drab
S	Carbon Steel, B1113, per QQ-S-637	Cadmium, Olive Drab per QQ-P-416, over Electroless Nickel per ASTM B733-90 and MIL-C-26074, 500 Hour Salt Spray