

## ■ General Description

The AME8822 family of positive, linear regulators feature low quiescent current (30 $\mu$ A typ.) low dropout voltage and excellent PSRR, thus making them ideal for telecommunications and other battery applications.

These rugged devices have both thermal shutdown and current limit to prevent device failure under the "Worst" operating conditions.

The AME8822 is stable with an output capacitance of 1 $\mu$ F or larger.

## ■ Features

- Very Low Dropout Voltage
- Fast Turn on Time 100 $\mu$ S(Typ.)
- Guaranteed 250mA Output
- 30 $\mu$ A Quiescent Current
- Over-Temperature Shutdown
- Excellent PSRR (Typ. 65dB)
- Power-Saving Shutdown Mode in SOT-25, TSOT-25A, SOT-23, TSOT-23A & SC-70-5 DFN-4A Packages
- Low Temperature Coefficient
- Green Products Meet RoHS Standards.

## ■ Applications

- Instrumentation
- Portable Electronics
- Wireless Devices
- PC Peripherals

## ■ Functional Block Diagram

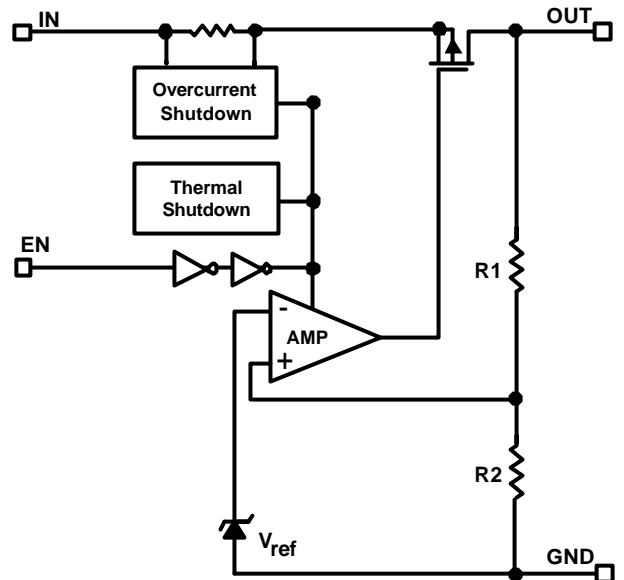

## ■ Typical Application

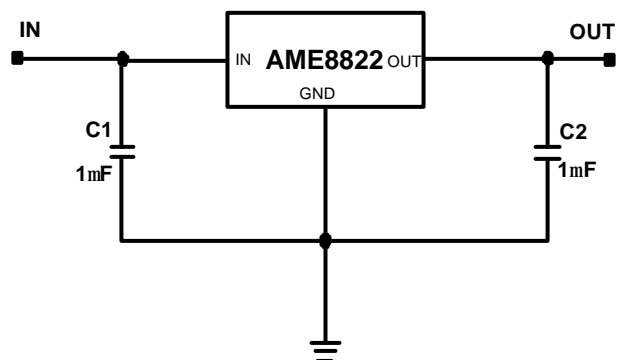
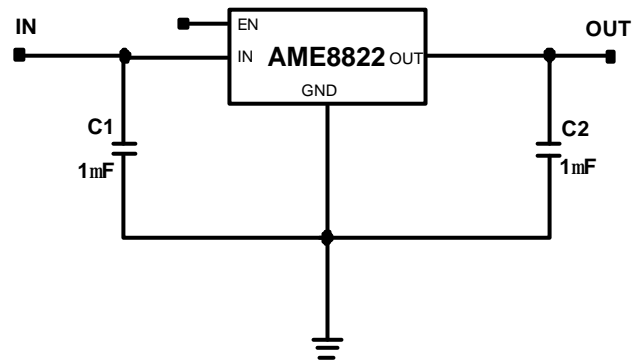

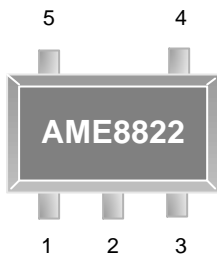
**■ Pin Configuration**
**SOT-25/TSOT-25A  
Top View**

**AME8822AEEV**

1. IN
2. GND
3. EN
4. NC
5. OUT

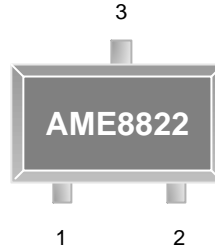
**\* Die Attach:**  
**Conductive Epoxy**

**SOT-23/TSOT-23A  
Top View**

**AME8822AEET**

1. GND
2. OUT
3. IN

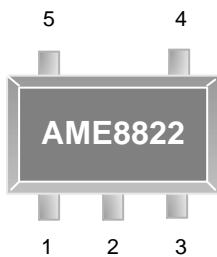
**\* Die Attach:**  
**Non-Conductive Epoxy**

**SC-70-5  
Top View**

**AME8822AEIV**

1. IN
2. GND
3. EN
4. NC
5. OUT

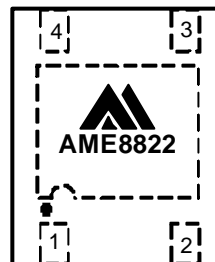
**\* Die Attach:**  
**Conductive Epoxy**

**DFN-4A  
Top View**

**AME8822AEVU**

1. OUT
2. GND
3. EN
4. IN

**\* Die Attach:**  
**Conductive Epoxy**

**■ Pin Description**
**AME8822AEET (SOT-23/TSOT-23A)**

Pin Number	Pin Name	Pin Description
1	GND	Ground connection pin.
2	OUT	LDO voltage regulator output pin. It should be decoupled with a 1mF or greater value low ESR ceramic capacitor.
3	IN	Input voltage pin. It should be decoupled with 1mF or greater capacitor.

**AME8822AEEV (SOT-25/TSOT-25A) / AME8822AEIV**

Pin Number	Pin Name	Pin Description
1	IN	Input voltage pin. It should be decoupled with 1mF or greater capacitor.
2	GND	Ground connection pin.
3	EN	Enable pin. When pulled low, the PMOS pass transistor turns off, current consuming less than 1mA.
4	NC	No Connection.
5	OUT	LDO voltage regulator output pin. It should be decoupled with a 1mF or greater value low ESR ceramic capacitor.

**AME8822AEVU (DFN-4A)**

Pin Number	Pin Name	Pin Description
1	OUT	LDO voltage regulator output pin. It should be decoupled with a 1mF or greater value low ESR ceramic capacitor.
2	GND	Ground connection pin.
3	EN	Enable pin. When pulled low, the PMOS pass transistor turns off, current consuming less than 1mA.
4	IN	Input voltage pin. It should be decoupled with 1mF or greater capacitor.

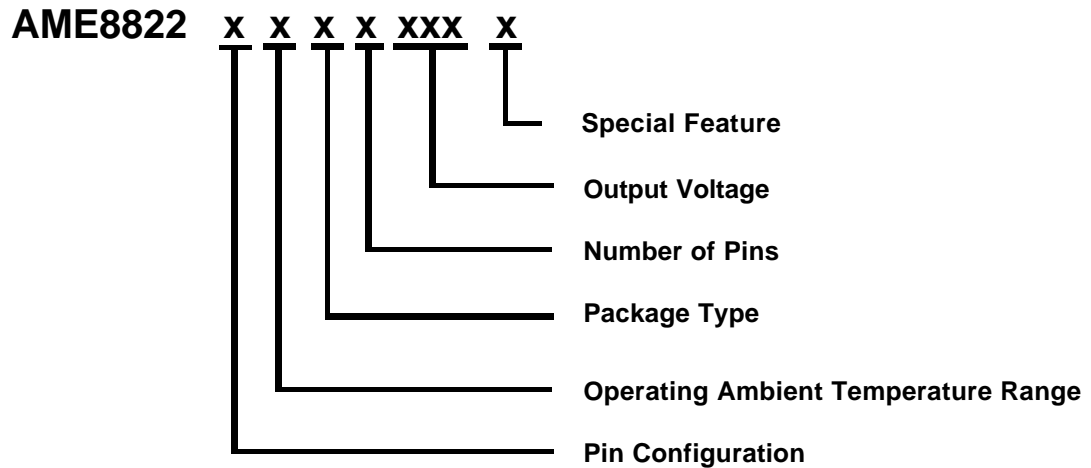
**■ Ordering Information**

Pin Configuration	Operating Ambient Temperature Range	Package Type	Number of Pins	Output Voltage	Special Feature
A: 1. IN <small>(SOT-25)</small> 2. GND <small>(TSOT-25A)</small> 3. EN 4. NC 5. OUT  A: 1. GND <small>(SOT-23)</small> 2. OUT <small>(TSOT-23A)</small> 3. IN  A: 1. IN <small>(SC-70-5)</small> 2. GND 3. EN 4. NC 5. OUT  A: 1. OUT <small>(DFN-4A)</small> 2. GND 3. EN 4. IN	E: -40°C to +85°C	E: SOT-2X I: SC-70 V: DFN	T: 3 V: 5 U: 4	120: V=1.2V 130: V=1.3V 150: V=1.5V 180: V=1.8V 250: V=2.5V 260: V=2.6V 270: V=2.7V 280: V=2.8V 290: V=2.9V 285: V=2.85V 300: V=3.0V 310: V=3.1V 330: V=3.3V	Z: Lead free K: 0.9mm max height (for TSOT-2XA Only)

**■ Ordering Information**

Part Number	Marking*	Output Voltage	Package	Operating Ambient Temperature Range
AME8822AEEV120Z	BIWww	1.2V	SOT-25	- 40°C to +85°C
AME8822AEEV150Z	BHKww	1.5V	SOT-25	- 40°C to +85°C
AME8822AEEV180Z	BHLww	1.8V	SOT-25	- 40°C to +85°C
AME8822AEEV250Z	BHMww	2.5V	SOT-25	- 40°C to +85°C
AME8822AEEV270Z	BHQww	2.7V	SOT-25	- 40°C to +85°C
AME8822AEEV280Z	BHNww	2.8V	SOT-25	- 40°C to +85°C
AME8822AEEV285Z	BHUww	2.85V	SOT-25	- 40°C to +85°C
AME8822AEEV300Z	BHOww	3.0V	SOT-25	- 40°C to +85°C
AME8822AEEV310Z	BHRww	3.1V	SOT-25	- 40°C to +85°C
AME8822AEEV330Z	BHPww	3.3V	SOT-25	- 40°C to +85°C
AME8822AEET120Z	BJJww	1.2V	SOT-23	- 40°C to +85°C
AME8822AEET150Z	BFZww	1.5V	SOT-23	- 40°C to +85°C
AME8822AEET180Z	BFOww	1.8V	SOT-23	- 40°C to +85°C
AME8822AEET250Z	BGAww	2.5V	SOT-23	- 40°C to +85°C
AME8822AEET280Z	BGBww	2.8V	SOT-23	- 40°C to +85°C
AME8822AEET300Z	BGCww	3.0V	SOT-23	- 40°C to +85°C
AME8822AEET330Z	BGDww	3.3V	SOT-23	- 40°C to +85°C
AME8822AEIV150Z	BJMw	1.5V	SC-70-5	- 40°C to +85°C
AME8822AEIV180Z	BJNw	1.8V	SC-70-5	- 40°C to +85°C
AME8822AEIV280Z	BJKw	2.8V	SC-70-5	- 40°C to +85°C
AME8822AEIV285Z	BJLw	2.85V	SC-70-5	- 40°C to +85°C



## AME8822

## High PSRR, 250mA CMOS LDO

### ■ Ordering Information (Contd.)

Part Number	Marking*	Output Voltage	Package	Operating Ambient Temperature Range
AME8822AEEV130Z	BLDww	1.3V	SOT-25	- 40°C to +85°C
AME8822AEEV260Z	BTUww	2.6V	SOT-25	- 40°C to +85°C
AME8822AEEV290Z	BTVww	2.9V	SOT-25	- 40°C to +85°C
AME8822AEIV330Z	BVJw	3.3V	SC-70-5	- 40°C to +85°C
AME8822AEET330K	CBGww	3.3V	TSOT-23A	- 40°C to +85°C
AME8822AEEV330K	BHPww	3.3V	TSOT-25A	- 40°C to +85°C
AME8822AEVU180Z	Ayw	1.8V	DFN-4A	- 40°C to +85°C

Note: ww represents the date code and pls refer to Date Code Rule page on Package Dimension.

\* A line on top of the first letter represents lead free plating such as  $\bar{B}$ IWww.

\* y is year code and is last number of a year. Such as the year the year code of 2008 is 8.

Please consult AME sales office or authorized Rep./Distributor for the availability of package type.

### ■ Absolute Maximum Ratings

Parameter	Maximum	Unit
Input Voltage	-0.3 to +7	V
EN Voltage	-0.3 to +7	V
Output Voltage	- 0.3 to $V_{IN} + 0.3$	V
Output Current	$P_D / (V_{IN} - V_{OUT})$	mA
ESD Classification	B*	

Caution: Stress above the listed absolute maximum rating may cause permanent damage to the device  
HBM B\*: 2000V ~ 3999V

**■ Recommended Operating Conditions**

Parameter	Symbol	Rating	Unit
Ambient Temperature Range	$T_A$	- 40 to +85	°C
Junction Temperature Range	$T_J$	- 40 to +125	°C
Storage Temperature Range	$T_{STG}$	- 65 to +150	°C

**■ Thermal Information**

Parameter	Package	Die Attach	Symbol	Maximum	Unit
Thermal Resistance (Junction to Ambient)	SOT-23	Non-Conductive Epoxy	$\theta_{JA}$	280	°C / W
	SOT-25	Conductive Epoxy		260	
	TSOT-25A			230	
	SC-70-5			331	
	DFN-4A			100	
Thermal Resistance (Junction to Case)	SOT-23*	Non-Conductive Epoxy	$\theta_{JC}$	140	
	SOT-25*	Conductive Epoxy		81	
	TSOT-25A*			81	
	SC-70-5*			N/A	
	DFN-4A				
Internal Power Dissipation	SOT-23	Non-Conductive Epoxy	$P_D$	400	mW
	SOT-25	Conductive Epoxy		400	
	TSOT-25A			455	
	SC-70-5			300	
	DFN-4A			N/A	
Maximum Junction Temperature				150	°C
Lead Temperature (Soldering 10 Sec)**				260	°C

\* Measure  $\theta_{JC}$  on backside center of molding compound if IC has no tab.

\*\* MIL-STD-202G 210F

**■ Electrical Specifications**

$V_{OUT(nom)} > 2.0V$ ,  $V_{IN}=V_{OUT(nom)}+0.5V$ ;  $V_{OUT} = 2V$ ,  $V_{IN}=2.5V$ ,  $V_{EN}=V_{IN}$ ,  $T_J = -40$  to  $125^{\circ}C$ ,  $C_{IN}=C_{OUT}=1mF$ , unless otherwise noted.

Parameter	Symbol	Test Condition	Min	Typ	Max	Units	
Input Voltage	$V_{IN}$		Note1		5.5	V	
Output Voltage Accuracy	$V_{OUT(nom)}$	$I_{OUT}=1mA$			1.5	%	
		$I_{OUT}=1mA$	$T_A=25^{\circ}C$	-1.5	1.5		
Dropout Voltage (See Note 1)	$V_{DROPOUT}$	$I_{OUT}=250mA$ $V_{OUT}=V_{OUT(nom)} - 2\%V_{OUT(nom)}$	$T_A=25^{\circ}C$		300	500	mV
		$I_{OUT}=250mA$	$V_{OUT} \leq 2.0V$ , $V_{DROPOUT}=2.5V-V_{OUT}$				
Current Limit	$I_{LIM}$	$V_{OUT}=0.8 \times V_{OUT(nom)}$	$T_A=25^{\circ}C$		350	500	mA
Short Circuit Limit	$I_{SC}$	$V_{OUT}=0V$ $V_{OUT} \leq 2V$ , $V_{IN}=3.5V$	$T_A=25^{\circ}C$		200		
Quiescent Current	$I_Q$	$V_{IN}=5V$ , $1mA < I_{OUT} < 250mA$	$T_A=25^{\circ}C$		30	45	$\mu A$
Line Regulation (See Note 2)	$REG_{LINE}$	$I_{OUT}=1mA$ , $V_{OUT} > 2.0V$ $V_{IN}=V_{OUT}+0.5V$ to $V_{IN}=5.5V$	$T_A=25^{\circ}C$	-0.25	0.1	0.25	%V
			$T_J=-40$ to $+125^{\circ}C$	-0.4		0.4	
		$I_{OUT}=1mA$ , $V_{OUT} \leq 2.0V$ $V_{IN}=2.5V$ to $V_{IN}=5.5V$	$T_A=25^{\circ}C$	-0.4	0.2	0.4	
			$T_J=-40$ to $+125^{\circ}C$	-0.6		0.6	
Load Regulation (See Note 3)	$REG_{LOAD}$	$I_{OUT} = 1$ to $250mA$	$V_{OUT} > 2.0V$ $V_{IN}=V_{OUT} + 0.5V$	-0.02	0.0025	0.02	%mA
			$V_{OUT} \leq 2.0V$ $V_{IN}=2.5V$	-0.04	0.004	0.04	
Over Temperature Shutdown	OTS	$I_{OUT}=0mA$			160	$^{\circ}C$	
Over Temperature Hysteresis	OTH	$I_{OUT}=0mA$			40	$^{\circ}C$	
$V_{OUT}$ Temperature Coefficient	TC				30	ppm/ $^{\circ}C$	
Power Supply Ripple Rejection	PSRR	$V_{OUT}=3.3V$ , $I_{OUT}=100mA$ , $C_{OUT}=10\mu F$ , $V_{IN}=V_{OUT}+1V$ , $f=1kHz$			65	dB	

Note1: If  $V_{OUT(nom)} > 2.0V$ ,  $V_{IN(min)}=V_{OUT(nom)}+V_{DROPOUT}$ . If  $V_{OUT(nom)} \leq 2.0V$ ,  $V_{IN(min)} = 2.5V$ .

$$\text{Note2: Line Regulation} = \frac{\frac{\Delta V_{out}}{\Delta V_{in}} \times 100\%}{V_{out}}$$

$$\text{Note3: Load Regulation} = \frac{\frac{\Delta V_{out}}{V_{out}} \times 100\%}{\Delta I(mA)}$$



**■ Electrical Specifications (contd.)**

Parameter	Symbol	Test Condition	Min	Typ	Max	Units
Output Voltage Noise	$e_N$	$f=10\text{Hz to }100\text{kHz}, I_{OUT}=10\text{mA}$		40		$\mu\text{Vrms}$
Enable Input Threshold*	$V_{ENH}$	$V_{OUT} \geq V_{OUT(\text{min})}$	1.4		$V_{IN}$	V
	$V_{ENL}$	$V_{OUT} \leq 0.2\text{V}$	0		0.3	V
Enable Input Bias Current*	$I_{EN}$	$V_{IN}=5\text{V}, EN=0\text{V or }5\text{V}$		0.01	1	$\mu\text{A}$
Shutdown Supply Current*	$I_{SD}$	$V_{IN}=5\text{V}, V_{EN}=0\text{V}$		0.5	1	$\mu\text{A}$
Shutdown Output Voltage*	$V_{O,SD}$	$I_{OUT}=1\text{mA}$			0.2	V

\* These parameters are applicable to part numbers with enable function.

## ■ Detailed Description

The AME8822 family of CMOS regulators contain a PMOS pass transistor, voltage reference, error amplifier, over-current protection, and thermal shutdown.

The P-channel pass transistor receives data from the error amplifier, over-current shutdown, and thermal protection circuits. During normal operation, the error amplifier compares the output voltage to a precision reference. Over-current and thermal shutdown circuits become active when the junction temperature exceeds 150°C, or the current exceeds 250mA. During thermal shutdown, the output voltage remains low. Normal operation is restored when the junction temperature drops below 130°C.

The AME8822 switches from voltage mode to current mode when the load exceeds the rated output current. This prevents over-stress.

## ■ External Capacitors

The AME8822 is stable with an output capacitor to ground of 1 $\mu$ F or larger. Ceramic capacitors have the lowest ESR, and will offer the best AC performance. Conversely, Aluminum Electrolytic capacitors exhibit the highest ESR, resulting in the poorest AC response.

A second capacitor is recommended between the input and ground to stabilize  $V_{IN}$ . The input capacitor should be at least 1 $\mu$ F to have a beneficial effect.

## ■ Enable

The Enable Pin is normally pull-high. When activated pulled low, the PMOS pass transistor shuts off, and all internal circuits are powered down. In this state, the standby current is less than 1 $\mu$ A. This pin can't be floating.

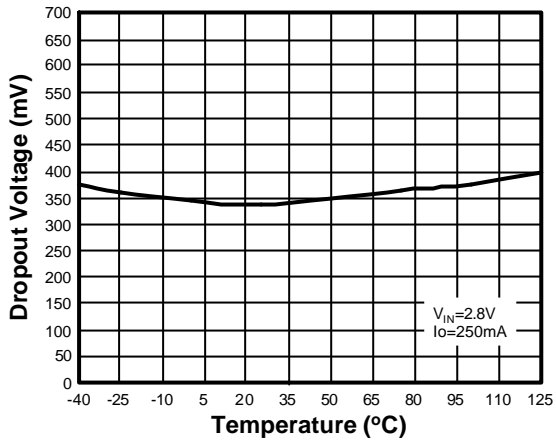
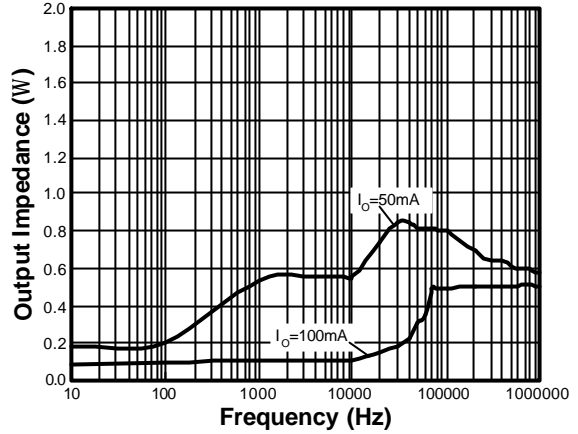
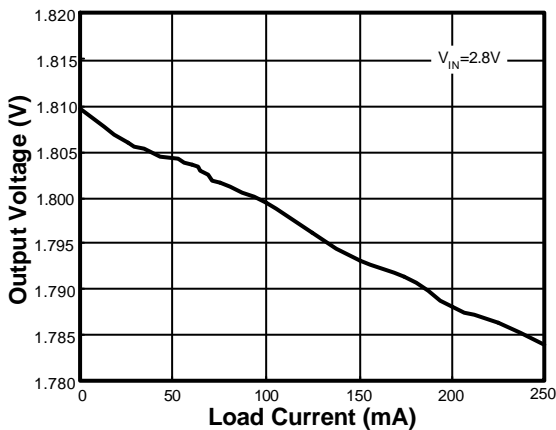
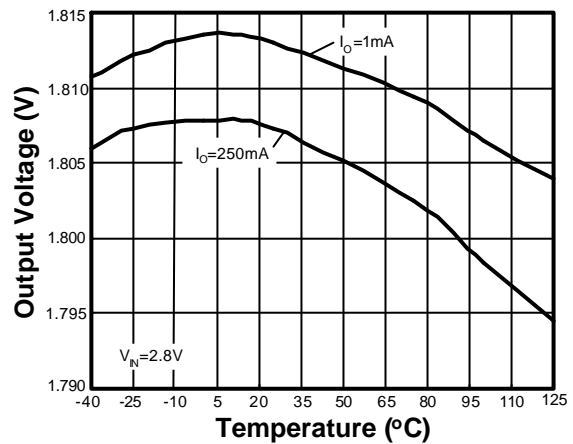
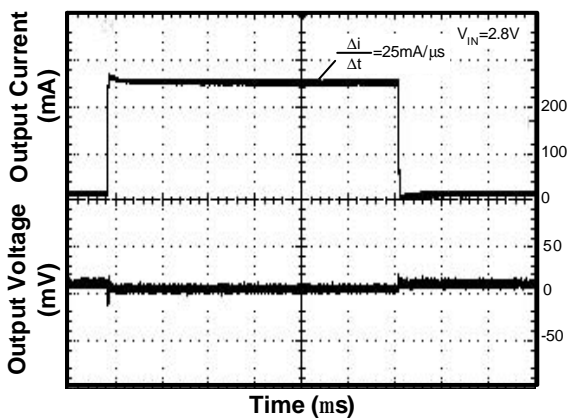
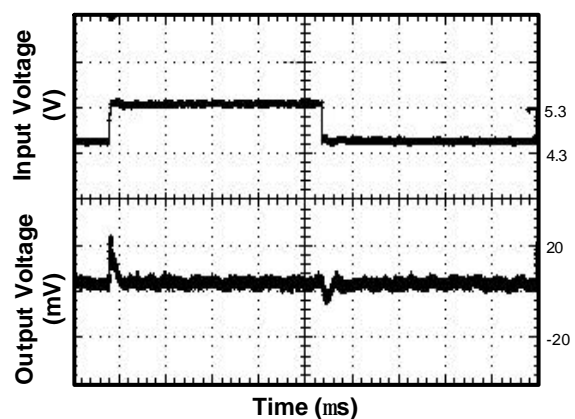
**Dropout Voltage vs Temperature**

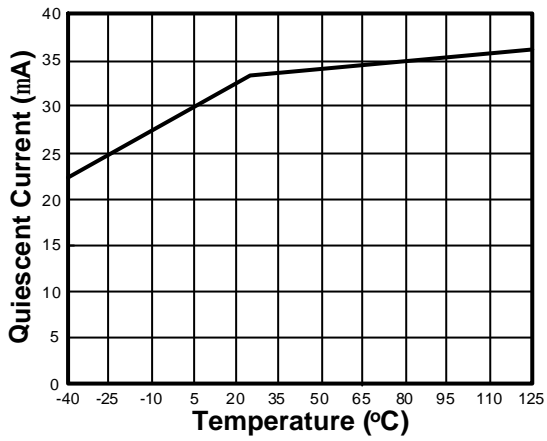
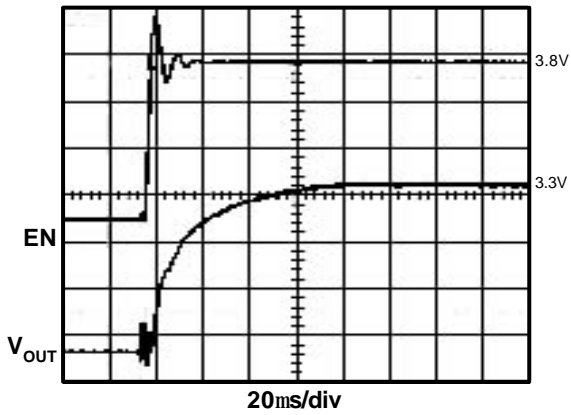
**Output Impedance vs Frequency**

**Output Voltage vs Load Current**

**Output Voltage vs Temperature**

**Load Transient Response**

**Line Transient Response**

**Quiescent Current vs Temperature****Rising Time**



# AME8822

# High PSRR, 250mA CMOS LDO

## ■ Date Code Rule

**For SOT-23/TSOT-23A/SOT-25/TSOT-25A Package Only**

Marking			Date Code		Year
A	A	A	W	W	xxx0
A	A	A	W	<u>W</u>	xxx1
A	A	A	<u>W</u>	W	xxx2
A	A	A	<u>W</u>	<u>W</u>	xxx3
A	A	<u>A</u>	W	W	xxx4
A	A	<u>A</u>	W	<u>W</u>	xxx5
A	A	<u>A</u>	<u>W</u>	W	xxx6
A	A	<u>A</u>	<u>W</u>	<u>W</u>	xxx7
A	<u>A</u>	A	W	W	xxx8
A	<u>A</u>	A	W	<u>W</u>	xxx9

**For DFN-4A Package Only**

w: Work Week Code		
A: 01&02	K: 21&22	U: 41&42
B: 03&04	L: 23&24	V: 43&44
C: 05&06	M: 25&26	W: 45&46
D: 07&08	N: 27&28	X: 47&48
E: 09&10	O: 29&30	Y: 49&50
F: 11&12	P: 31&32	Z: 51&52
G: 13&14	Q: 33&34	
H: 15&16	R: 35&36	
I: 17&18	S: 37&38	
J: 19&20	T: 39&40	

**For SC-70 Package Only**

Marking			Date Code	Year
A	A	A	W	xxx0
A	A	A	<u>W</u>	xxx1
A	A	<u>A</u>	W	xxx2
A	A	<u>A</u>	<u>W</u>	xxx3
A	<u>A</u>	A	W	xxx4
A	<u>A</u>	A	<u>W</u>	xxx5
A	<u>A</u>	<u>A</u>	W	xxx6
A	<u>A</u>	<u>A</u>	<u>W</u>	xxx7
<u>A</u>	A	A	W	xxx8
<u>A</u>	A	A	<u>W</u>	xxx9

w: Work Week Code		
A: 01&02	K: 21&22	U: 41&42
B: 03&04	L: 23&24	V: 43&44
C: 05&06	M: 25&26	W: 45&46
D: 07&08	N: 27&28	X: 47&48
E: 09&10	O: 29&30	Y: 49&50
F: 11&12	P: 31&32	Z: 51&52
G: 13&14	Q: 33&34	
H: 15&16	R: 35&36	
I: 17&18	S: 37&38	
J: 19&20	T: 39&40	

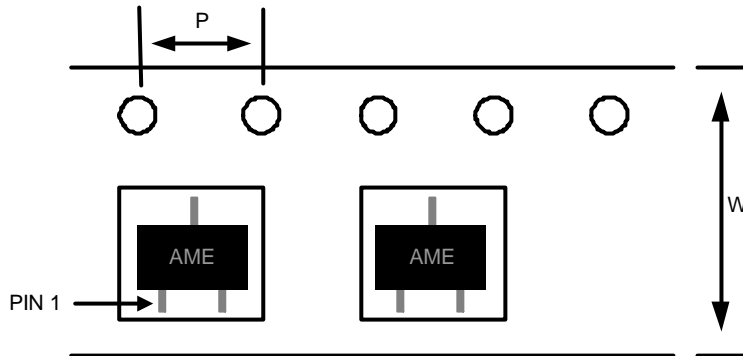
**■ Tape and Reel Dimension**
**SOT-23**

**Carrier Tape, Number of Components Per Reel and Reel Size**

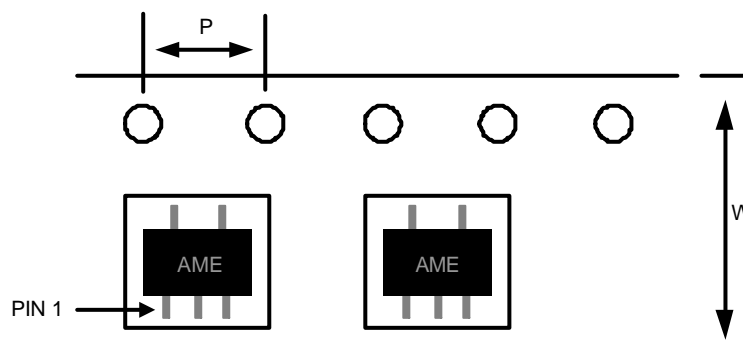
Package	Carrier Width (W)	Pitch (P)	Part Per Full Reel	Reel Size
SOT-23	8.0±0.1 mm	4.0±0.1 mm	3000pcs	180±1 mm

**SOT-25**

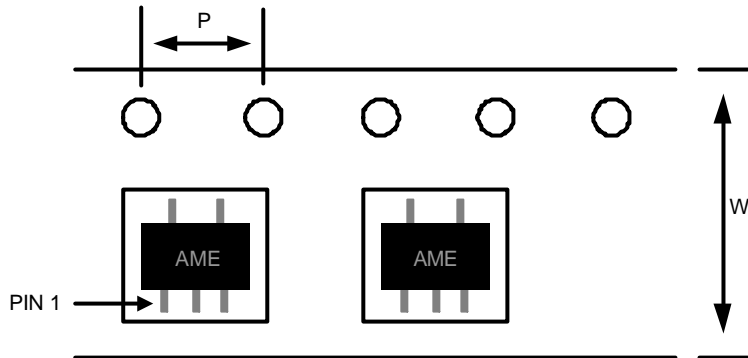
**Carrier Tape, Number of Components Per Reel and Reel Size**

Package	Carrier Width (W)	Pitch (P)	Part Per Full Reel	Reel Size
SOT-25	8.0±0.1 mm	4.0±0.1 mm	3000pcs	180±1 mm

**■ Tape and Reel Dimension (Contd.)**
**SC-70-5**

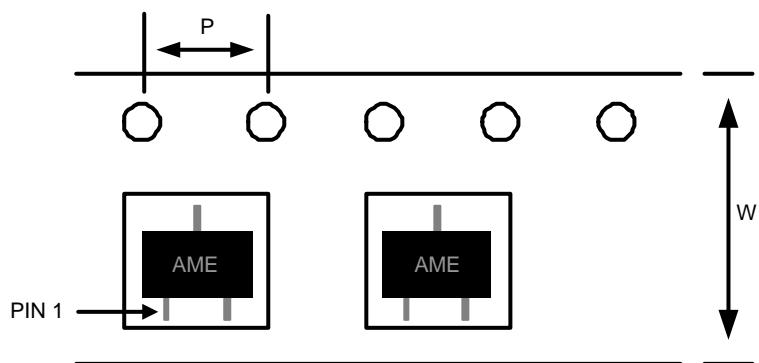
**Carrier Tape, Number of Components Per Reel and Reel Size**

Package	Carrier Width (W)	Pitch (P)	Part Per Full Reel	Reel Size
SC-70-5	8.0±0.1 mm	4.0±0.1 mm	3000pcs	180±1 mm

**TSOT-23A**

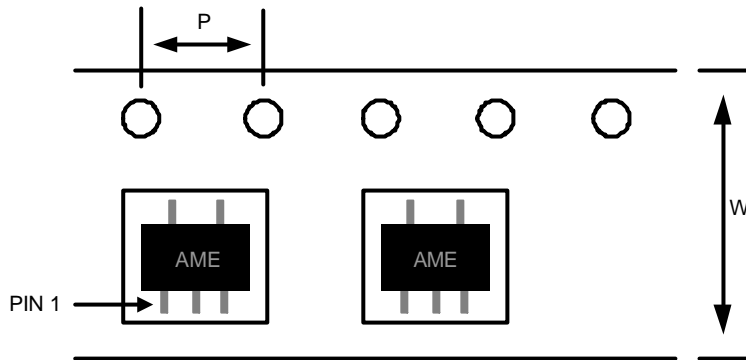
**Carrier Tape, Number of Components Per Reel and Reel Size**

Package	Carrier Width (W)	Pitch (P)	Part Per Full Reel	Reel Size
TSOT-23A	8.0±0.1 mm	4.0±0.1 mm	3000pcs	180±1 mm

**■ Tape and Reel Dimension (contd.)**
**TSOT-25A**

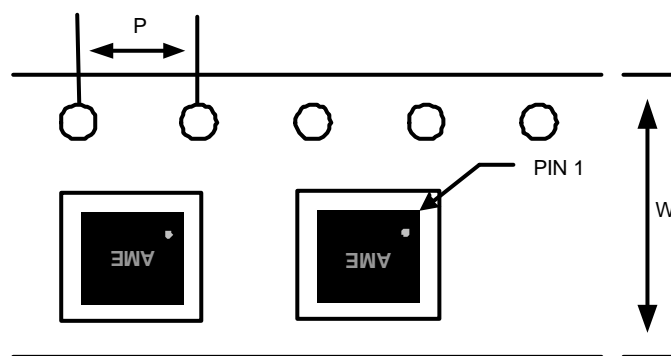
**Carrier Tape, Number of Components Per Reel and Reel Size**

Package	Carrier Width (W)	Pitch (P)	Part Per Full Reel	Reel Size
TSOT-25A	8.0±0.1 mm	4.0±0.1 mm	3000pcs	180±1 mm

**DFN-4A (1.2mmX1.6mmX0.55mm)**

**Carrier Tape, Number of Components Per Reel and Reel Size**

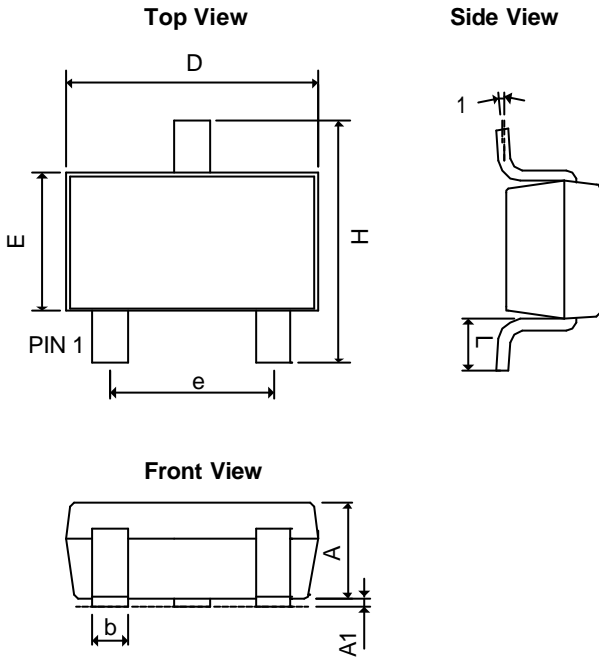
Package	Carrier Width (W)	Pitch (P)	Part Per Full Reel	Reel Size
DFN-4A (1.2x1.6x0.55mm)	8.0±0.1 mm	4.0±0.1 mm	3000pcs	180±1 mm

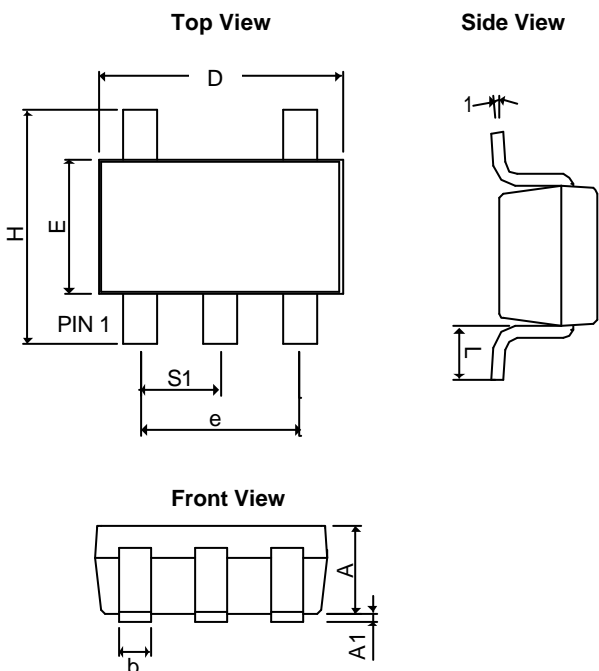

**■ Package Dimension**
**SOT-23**

SYMBOLS	MILLIMETERS		INCHES	
	MIN	MAX	MIN	MAX
A	0.90	1.40	0.0354	0.0551
A <sub>1</sub>	0.00	0.15	0.0000	0.0059
b	0.30	0.50	0.0118	0.0197
D	2.70	3.10	0.1063	0.1220
E	1.40	1.80	0.0551	0.0709
e	1.90 BSC		0.0748 BSC	
H	2.40	3.00	0.0945	0.1181
L	0.35BSC		0.0138 BSC	
q1	0°	10°	0°	10°

**SOT-25**

SYMBOLS	MILLIMETERS		INCHES	
	MIN	MAX	MIN	MAX
A	0.90	1.30	0.0354	0.0512
A <sub>1</sub>	0.00	0.15	0.0000	0.0059
b	0.30	0.55	0.0118	0.0217
D	2.70	3.10	0.1063	0.1220
E	1.40	1.80	0.0551	0.0709
e	1.90 BSC		0.0748 BSC	
H	2.60	3.00	0.1024	0.1181
L	0.37 BSC		0.0146 BSC	
q1	0°	10°	0°	10°
S <sub>1</sub>	0.95 BSC		0.0374 BSC	

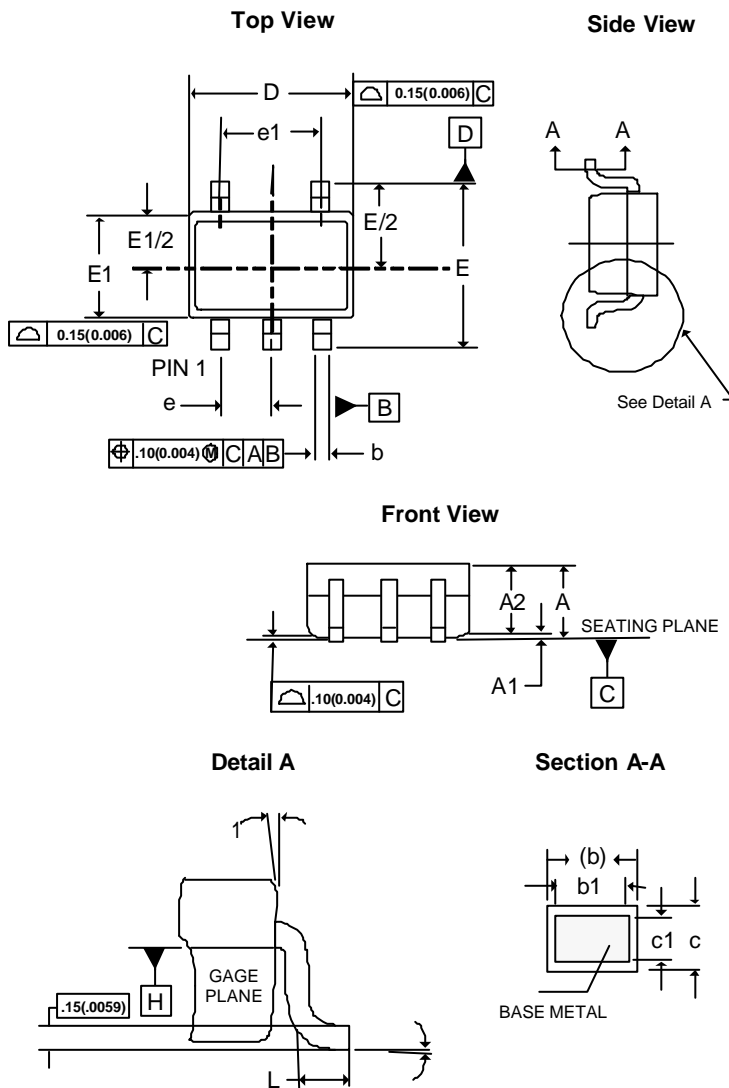
**■ Package Dimension**
**SC-70-5**

SYMBOLS	MILLIMETERS		INCHES	
	MIN	MAX	MIN	MAX
A	0.80	1.10	0.0315	0.0433
A1	0.00	0.10	0.0000	0.0039
A2	0.80	1.00	0.0315	0.0394
b	0.15	0.35	0.0059	0.0138
b1	0.15	0.25	0.0059	0.0098
c	0.08	0.25	0.0031	0.0098
c1	0.08	0.20	0.0031	0.0079
D	1.85	2.20	0.0728	0.0866
E	1.80	2.45	0.0709	0.0965
E1	1.10	1.40	0.0433	0.0551
e	0.65 BSC		0.0255 BSC	
e1	1.20	1.40	0.0472	0.0551
L	0.26	0.46	0.0102	0.0181
q1	0°	8°	0°	8°
q	4°	10°	4°	10°

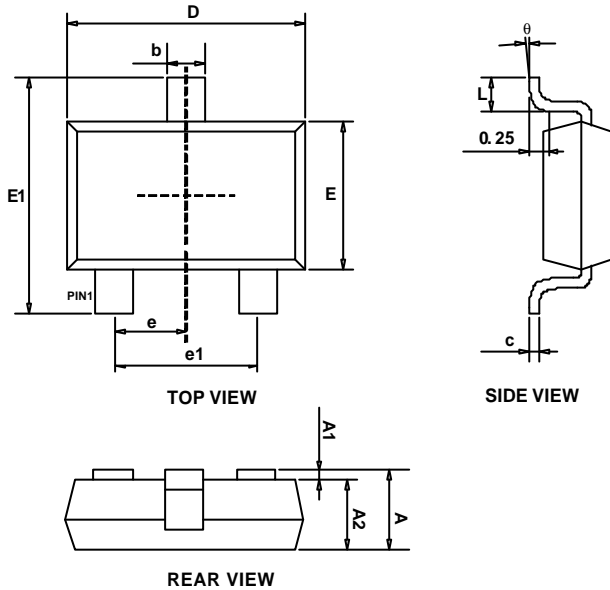
**■ Package Dimension**
**TSOT-23A**

SYMBOLS	MILLIMETERS		INCHES	
	MIN	MAX	MIN	MAX
A	0.700	0.900	0.028	0.035
A1	0.000	0.100	0.000	0.004
A2	0.700	0.800	0.028	0.031
b	0.350	0.500	0.014	0.020
c	0.080	0.200	0.003	0.008
D	2.820	3.020	0.111	0.119
E	1.600	1.700	0.063	0.067
E1	2.650	2.950	0.104	0.116
e	0.95 BSC		0.037 BSC	
e1	1.90 BSC		0.075 BSC	
L	0.300	0.600	0.012	0.024
q	0°	8°	0°	8°

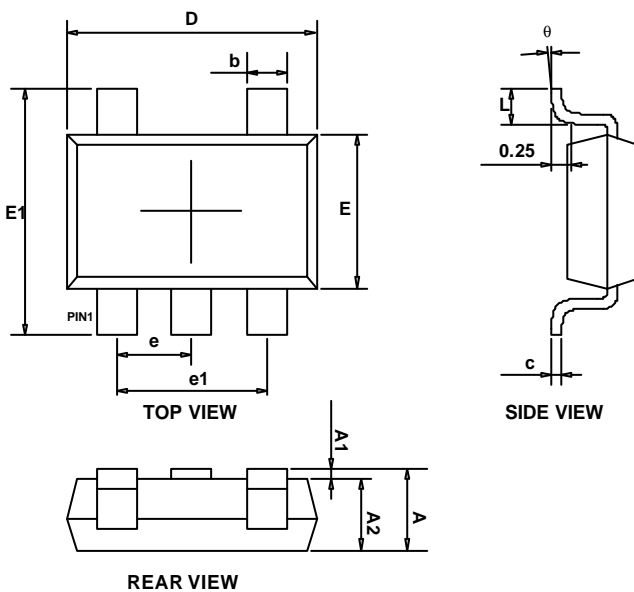
**TSOT-25A**

SYMBOLS	MILLIMETERS		INCHES	
	MIN	MAX	MIN	MAX
A	0.700	0.900	0.028	0.035
A1	0.000	0.100	0.000	0.004
A2	0.700	0.800	0.028	0.031
b	0.350	0.500	0.014	0.020
c	0.080	0.200	0.003	0.008
D	2.820	3.020	0.111	0.119
E	1.600	1.700	0.063	0.067
E1	2.650	2.950	0.104	0.116
e	0.95 BSC		0.037 BSC	
e1	1.90 BSC		0.075 BSC	
L	0.300	0.600	0.012	0.024
q	0°	8°	0°	8°

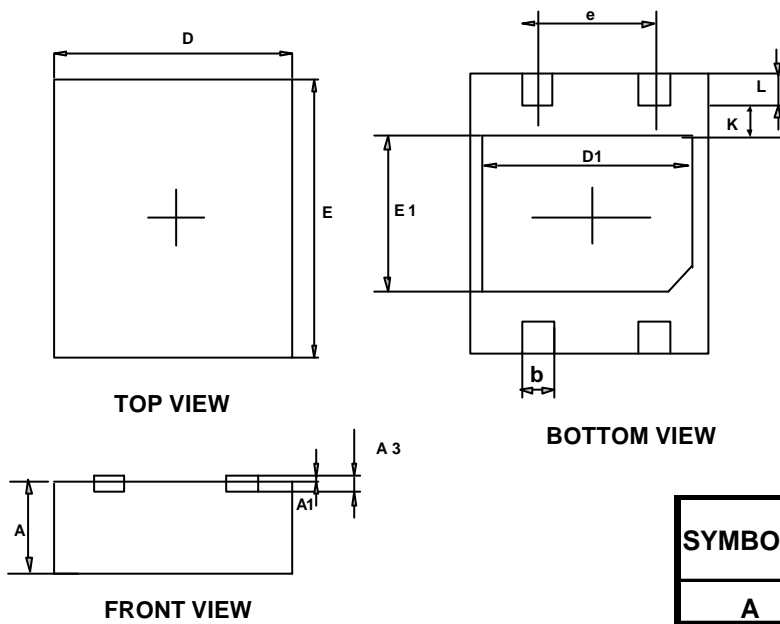
**■ Package Dimension**
**DFN-4A**  
**(1.2mmx1.6mmx0.55mm)**

SYMBOLS	MILLIMETERS		INCHES	
	MIN	MAX	MIN	MAX
<b>A</b>	0.450	0.550	0.018	0.020
<b>A1</b>	0.000	0.050	0.000	0.002
<b>A3</b>	-	-	0.006	
<b>D</b>	1.150	1.250	0.045	0.049
<b>E</b>	1.550	1.650	0.061	0.065
<b>E1</b>	0.650	0.750	0.026	0.030
<b>D1</b>	0.950	1.050	0.037	0.041
<b>k</b>	0.200		0.008	
<b>b</b>	0.250	0.350	0.010	0.014
<b>e</b>	0.600		0.240	
<b>L</b>	0.124	0.276	0.005	0.011



**www.ame.com.tw**  
**E-Mail: sales@ame.com.tw**

Life Support Policy:

These products of AME, Inc. are not authorized for use as critical components in life-support devices or systems, without the express written approval of the president of AME, Inc.

AME, Inc. reserves the right to make changes in the circuitry and specifications of its devices and advises its customers to obtain the latest version of relevant information.

© AME, Inc. , January 2013  
Document: 1003-DS8822-F.04

**Corporate Headquarter**  
**AME, Inc.**

8F, 12 WenHu St., Nei-Hu  
Taipei 114, Taiwan .  
Tel: 886 2 2627-8687  
Fax: 886 2 2659-2989