

SERIES: AMT10X | DESCRIPTION: MODULAR ENCODER
FEATURES

- patented capacitive technology
- 16 dip switch programmable resolutions
- straight (radial) and right-angle (axial) versions
- 9 different mounting hole options for AMT102
- 6 different mounting hole options for AMT103
- low power consumption
- line driver output available (CUI-10XE-10)
- -40°C to 100°C operating temperature
- TTL voltage output
- modular package

ELECTRICAL

parameter	conditions/description	min	typ	max	units
power supply		3.6		5.5	V
current consumption	excluding output load		6	10	mA
incremental output signals	Quadrature A/B and X index ($\bar{A}/\bar{B}/\bar{X}$ line driver available with CUI-10XE-10)				
output phase difference	90° (B ch leads A ch in CW direction viewed from front)				
incremental output waveform	TTL voltage square wave				
incremental output resolutions ²	48, 96, 100, 125, 192, 200, 250, 256, 384, 400, 500, 512, 800, 1000, 1024, 2048				PPR
index	one pulse per 360 deg.				
output current	sink/source line driver cable (sink/source)			10 20	mA mA
accuracy ³	±15 arcmin (at 192, 384, 400, 500, 800, 1000, 1024, 2048 ppr) ±30 arcmin (at 96, 200, 250, 512 ppr) ±60 arcmin (at 48, 100, 125, 256 ppr)				
rotational speed	at 192, 384, 400, 500, 800, 1000, 1024, 2048 ppr at 48, 96, 100, 125, 200, 250, 256, 512 ppr			7,500 15,000	rpm rpm
square wave duty cycle	50% ±2% (at 256, 512, 1024, 2048) 50% ±≤6% (at 48, 96, 100, 125, 192, 200, 250, 384, 400, 500) 50% ±≤12% (at 800, 1000)				

1. Some stepper motors may leak a magnetic field causing the AMT index pulse to not function properly.

2. All resolutions stated are before quadrature decoding. (example: 1000 ppr x 4 = 4000 counts)

3. Based on full production testing standards and includes all electronic and mechanical based errors, not a computed estimate.

MECHANICAL

parameter	conditions/description	min	typ	max	units
weight	AMT102 AMT103		20.5 14.0		g g
axial play				±0.3	mm
angular acceleration				1x10 ⁴	rad/sec ²

ENVIRONMENTAL

parameter	conditions/description	min	typ	max	units
operating temperature		-40		100	°C
humidity	non-condensing			95	%
vibration	20 ~ 500 Hz, 1 hour each XYZ			10	G
shock	11 ms pulse, ±XYZ direction			50	G

PART NUMBER KEY

For customers that prefer a specific AMT10X configuration, please reference the custom configuration key below.

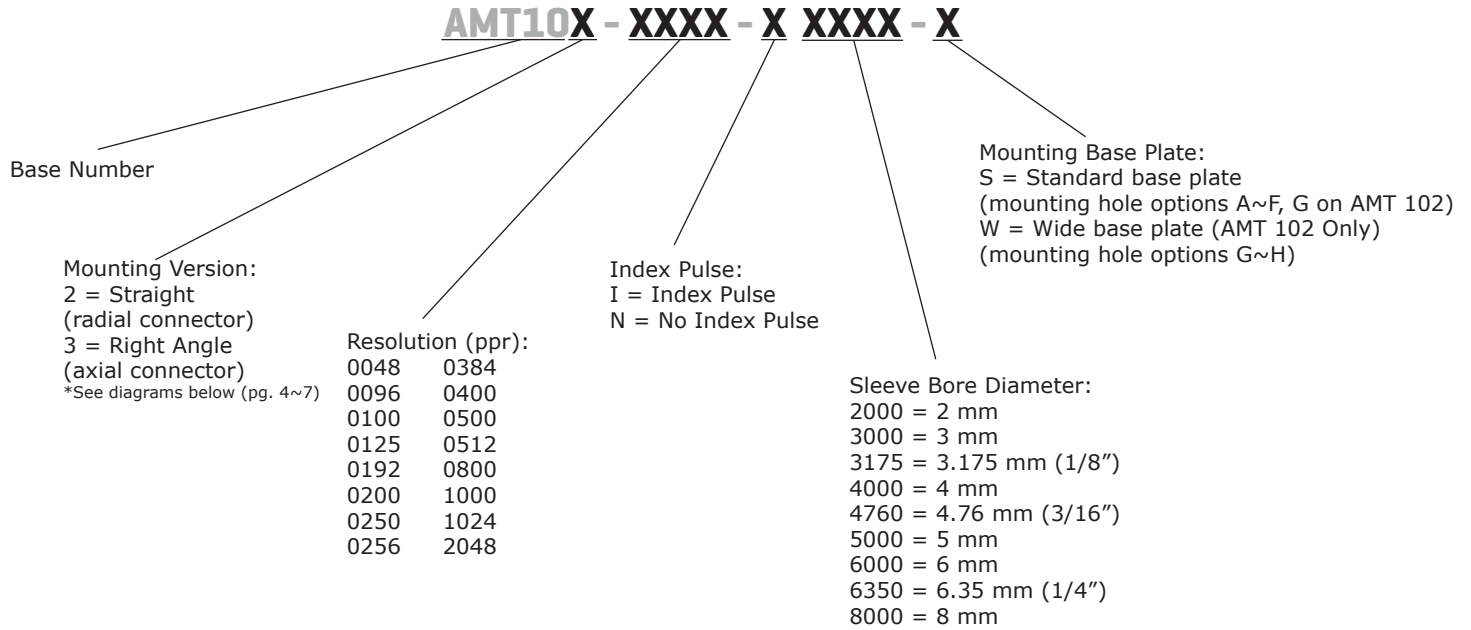

AMT10X-V KITS

In order to provide maximum flexibility for our customers, the AMT10X series is provided in kit form standard. This allows the user to implement the encoder into a range of applications using one sku#, reducing engineering and inventory costs.

ORDERING GUIDE AMT10X-V

Mounting Version:
 2 = Straight (radial connector)
 3 = Right Angle (axial connector)
 *See diagrams below (pg. 4~7)

SLEEVES								
8mm	1/4 inch (6.35mm)	6mm	5mm	3/16 inch (4.76mm)	4mm	1/8 inch (3.175mm)	3mm	2mm
Blue	Snow	Red1	Green1	Yellow1	Gray60	Purple1	Orange	Light Sky Blue

102 BASE 	102 WIDE BASE 	102 TOP COVER 	SHAFT ADAPTER
103 BASE 	103 TOP COVER 	TOOL A 	TOOL B

RESOLUTION SETTINGS

1 = On, 0 = Off

Resolution (PPR)	Maximum RPM	1	2	3	4
2048	7500	0	0	0	0
1024	7500	0	0	1	0
1000	7500	1	0	0	0
800	7500	0	1	0	0
512	15000	0	0	0	1
500	7500	1	0	1	0
400	7500	0	1	1	0
384	7500	1	1	0	0
256	15000	0	0	1	1
250	15000	1	0	0	1
200	15000	0	1	0	1
192	7500	1	1	1	0
125	15000	1	0	1	1
100	15000	0	1	1	1
96	15000	1	1	0	1
48	15000	1	1	1	1

DIP switch:
Example setting: 500 PPR

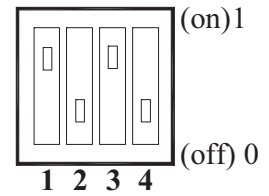

ASSEMBLY PROCEDURE

STEP 1

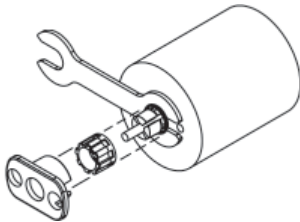

1. Insert Tool A as a spacer that defines the distance to the mounting surface.
2. Slide appropriate sized Sleeve over shaft all the way down to Tool A.
3. Slide Shaft Adaptor over Sleeve.
4. Use Tool B to press Shaft Adaptor over Sleeve until flush with Tool A.

STEP 2

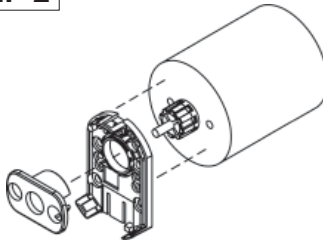

5. Remove Tools A and B.
6. Place Base on motor, with Tool B used as a centering tool.

STEP 3

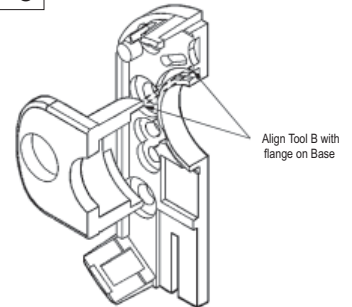

- 6a. Align Tool B with flange on Base.
- 6b. Slide Base and Tool B onto motor, centering onto the Shaft Adaptor.

STEP 4

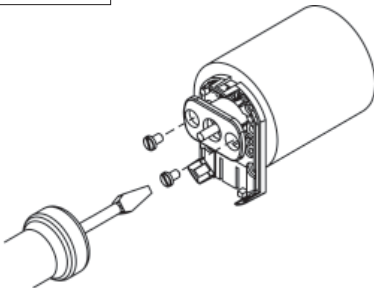

7. Fasten the Base on the motor.
8. Remove Tool B.

STEP 5

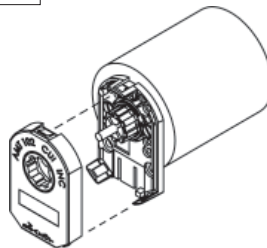

9. Slide the Top Cover onto the Base, carefully observing that the teeth of the Shaft Adaptor align with the grooves in the hub.

STEP 6

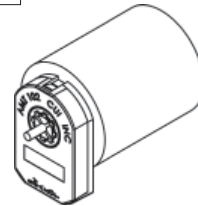

10. Make sure the snaps are fully engaged and the Top Cover is flush with the Base.
11. When assembly is finished, the Shaft Adaptor should be about flush with the front of the Encoder and the Motor Shaft should rotate freely.

MECHANICAL DRAWING

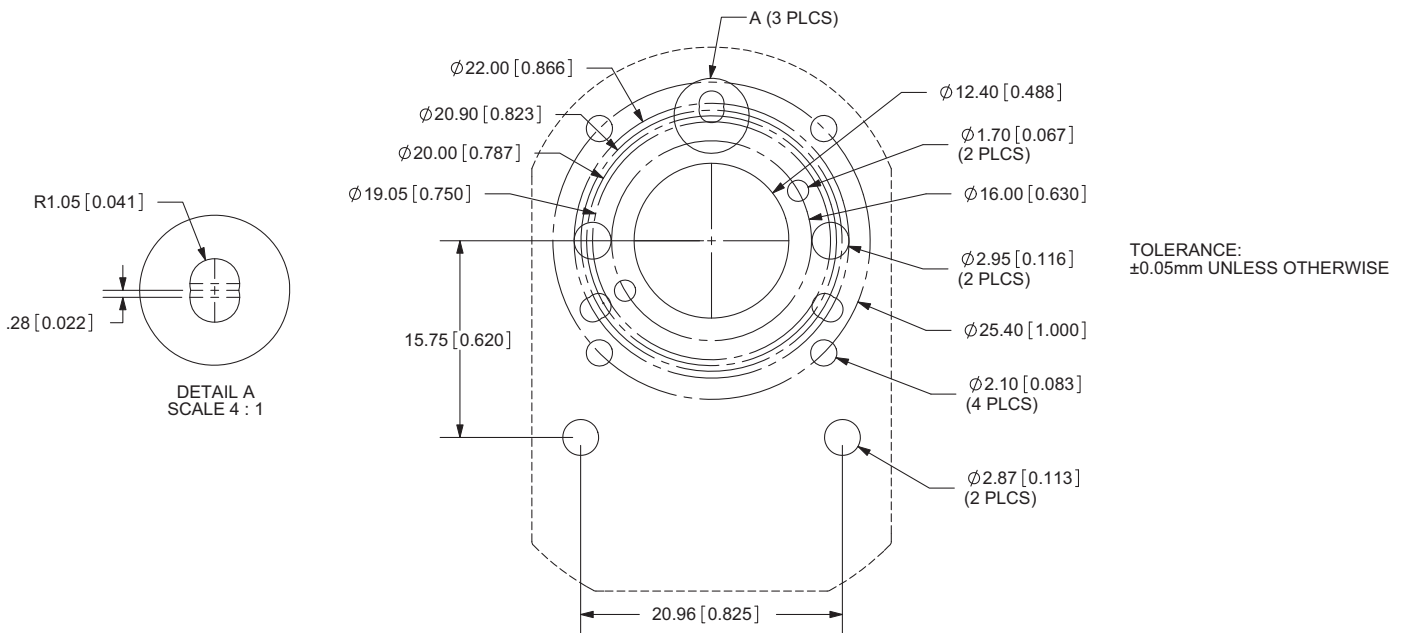
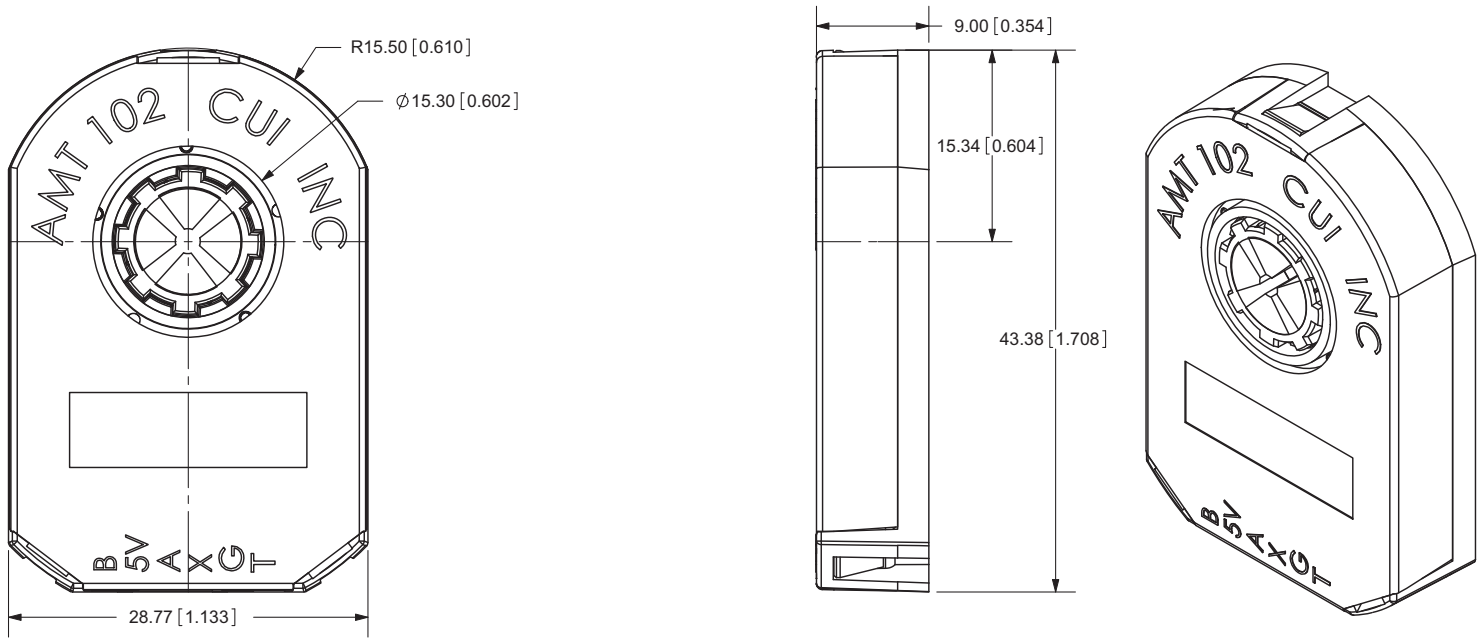

MECHANICAL DRAWING

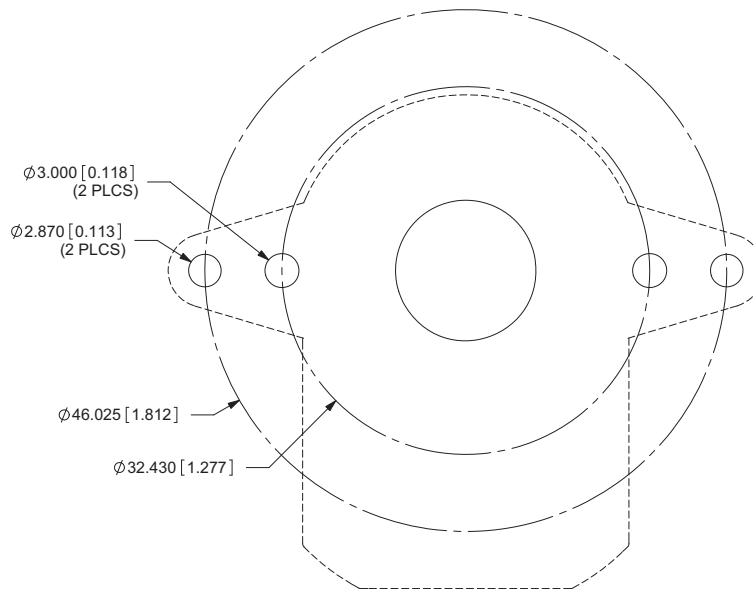
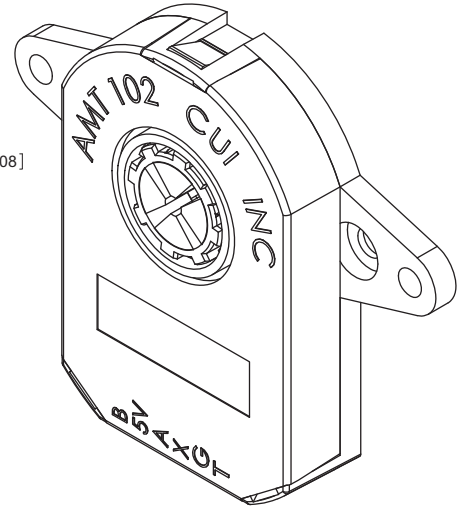
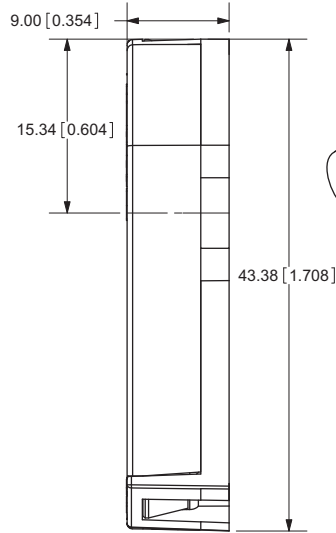
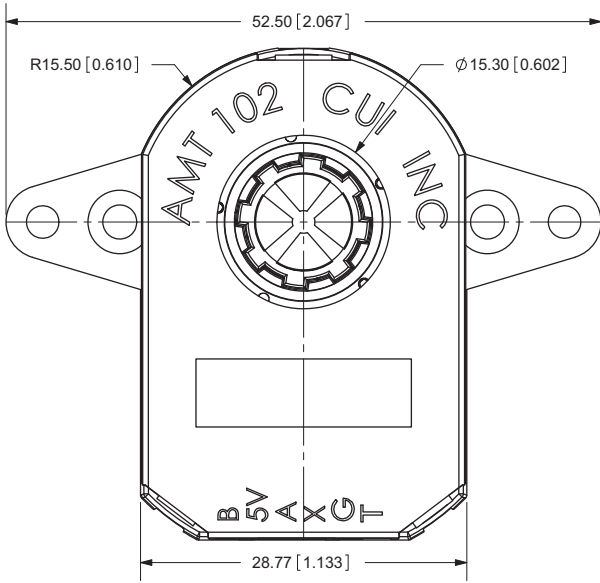

TOLERANCE:
 $\pm 0.05\text{mm}$ UNLESS OTHERWISE
SPECIFIED

MECHANICAL DRAWING

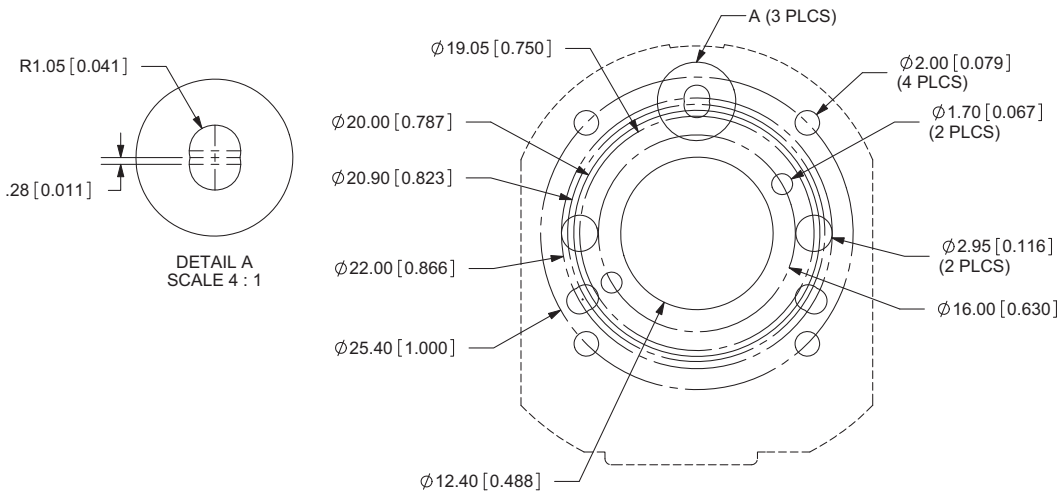
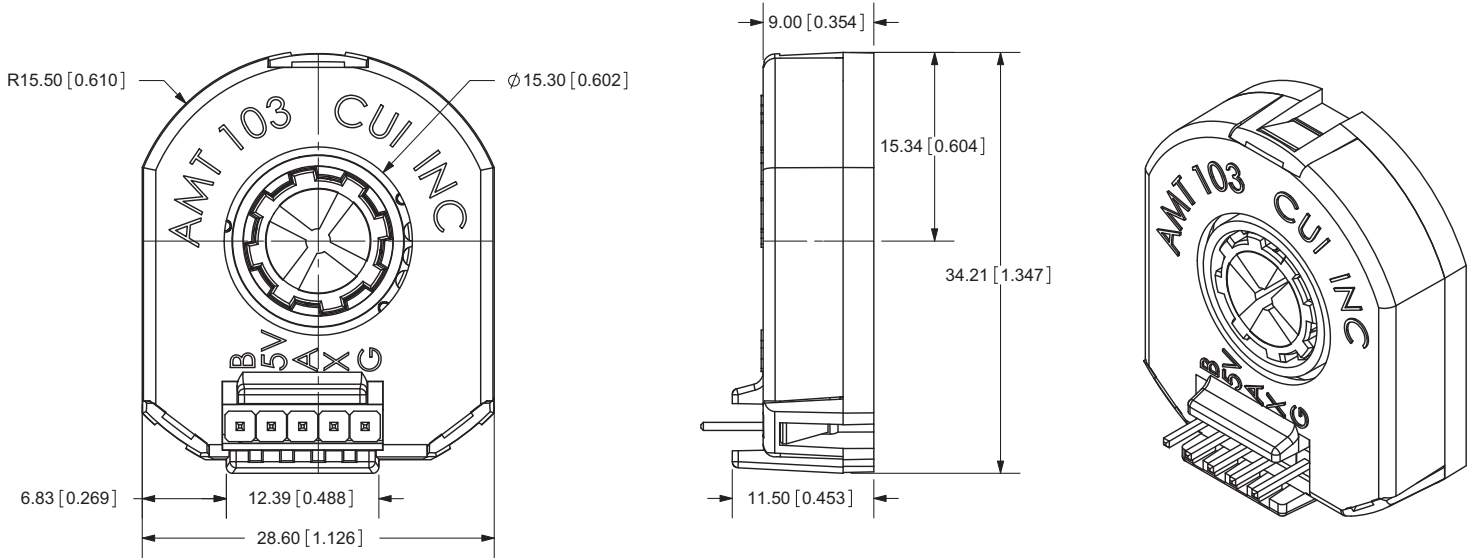

TOLERANCE:
 $\pm 0.05\text{mm}$ UNLESS OTHERWISE
 SPECIFIED

MECHANICAL DRAWING

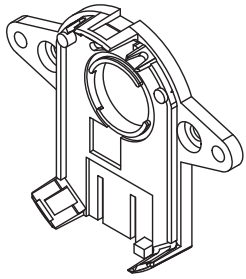

PIN-OUT	
PIN	DESCRIPTION
B	B CHANNEL
5V	+5VDC POWER
A	A CHANNEL
X	INDEX OUPUT
G	GROUND
T	UNUSED

MATING CONNECTOR
 MOLEX 50-57-9405 HOUSING
 MOLEX 16-02-0086 TERMINALS

CABLES AVAILABLE
 (SOLD SEPERATELY)

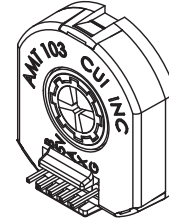
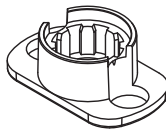
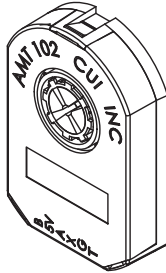
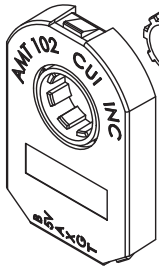
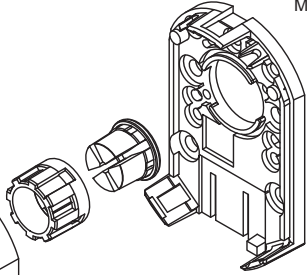

PIN-OUT	
PIN	DESCRIPTION
B	B CHANNEL
5V	+5VDC POWER
A	A CHANNEL
X	INDEX OUPUT
G	GROUND

MATING CONNECTOR
 AMP 3-640440-5 (TIN)
 AMP 3-641237-5 (GOLD)

CABLES AVAILABLE
 (SOLD SEPERATELY)

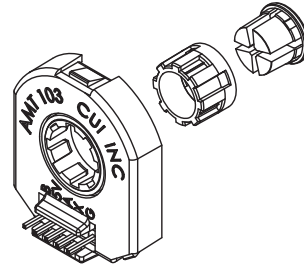
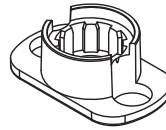

REVISION HISTORY

rev.	description	date
1.0	initial release	05/04/2011
1.01	updated electrical specifications	07/11/2011
1.02	updated electrical specifications	09/16/2011
1.03	updated resolution table and electrical specifications	10/18/2012
1.04	updated part number key	11/20/2012
1.05	updated spec, updated DIP switch table	07/26/2013

The revision history provided is for informational purposes only and is believed to be accurate.



Headquarters
20050 SW 112th Ave.
Tualatin, OR 97062
800.275.4899

Fax 503.612.2383
cui.com
techsupport@cui.com

CUI offers a one (1) year limited warranty. Complete warranty information is listed on our website.

CUI reserves the right to make changes to the product at any time without notice. Information provided by CUI is believed to be accurate and reliable. However, no responsibility is assumed by CUI for its use, nor for any infringements of patents or other rights of third parties which may result from its use.

CUI products are not authorized or warranted for use as critical components in equipment that requires an extremely high level of reliability. A critical component is any component of a life support device or system whose failure to perform can be reasonably expected to cause the failure of the life support device or system, or to affect its safety or effectiveness.